

NATIONAL RADIO ASTRONOMY OBSERVATORY

MEMORANDUM

February 7, 1967

To: Scientific Staff
G. Westerhout
C. Heiles
A. Shalloway
S. Weinreb
J. Dolan

From: M. Balister MB

Subject: 4-Feed 21 cm Front-End for 300-Foot Telescope

This note describes the 4-channel receiver proposed for continuum and line work on the 300-foot telescope. The receiver will be complete by September 1967.

An attempt is being made to minimize loss of observing time due to equipment failures by use of redundancy techniques. Pump power and local oscillator signals will be levelled in order to reduce gain variations to as low a level as possible. A sweeper will be put in the front-end box to enable the frequency response of each receiver to be examined in the control room of the telescope.

A block diagram is attached to this note; the following paragraphs explain the important areas:

1) Paramps

These (4) have been ordered from Micromega. They will have an instantaneous gain of 15 dB over the frequency range 1350-1430 Mc/s. The noise temperature of the paramp will be 70 °K maximum with no second stage contribution. A receiver noise temperature of 100° is the objective; this includes second stage, switch and coupler noise contributions.

2) Pump

The pump frequency will be in the range 20-26 kMc/s and a maximum of 50 mW per paramp will be required.

In the block diagram two klystrons are shown connected via three 3 dB couplers to distribute the pump signal to the four paramps. One of these klystrons will be used to supply pump power to all 4 paramps; the other is used as a spare in case the first fails. The changeover will only require switching on separate high voltage power supplies supplying the second klystron; the first klystron can be left connected in the waveguide circuit since it is isolated by the hybrid and isolator.

2) Pumps (continued) --

Each paramp will have its own pump leveller circuit to minimize gain changes due to fluctuations in klystron output power.

3) 2nd Stage

At this time it has not been decided whether to use a tunnel diode or transistor second stage. The gain will be about 15 dB and noise temperature will be about 500° for either amplifier.

A 3 dB coupler, filter and isolator follow the second stage. A swept frequency signal is injected into the receiver via the noise tube mount. The coupler monitors the amplified signal and the frequency response of the paramp and second stage can be examined.

4) Mixer/Preamplifier

The preamplifier will have an IF center frequency of 150 Mc/s and a bandwidth of 100 Mc/s, making the system compatible with the new autocorrelation and new standard receiver.

5) Local Oscillator

There will be two alternatives. An internal oscillator at about 1260 Mc/s can be used for continuum work. A local oscillator signal can also be sent up from the control building for line work. No RF switching is necessary since the 3 dB loss of a hybrid can be tolerated by both internal and external local oscillators. A levelling loop will be used with each local oscillator.

6) Noise Tube

Two noise tubes will be incorporated in the system; both will be fully operational. However, normally only one will be used; in the event of a failure of this tube, then the other can be used. The highest cal signal possible with the arrangement shown will be 25°.

MB/cjd

Enclosure
Block Diagram

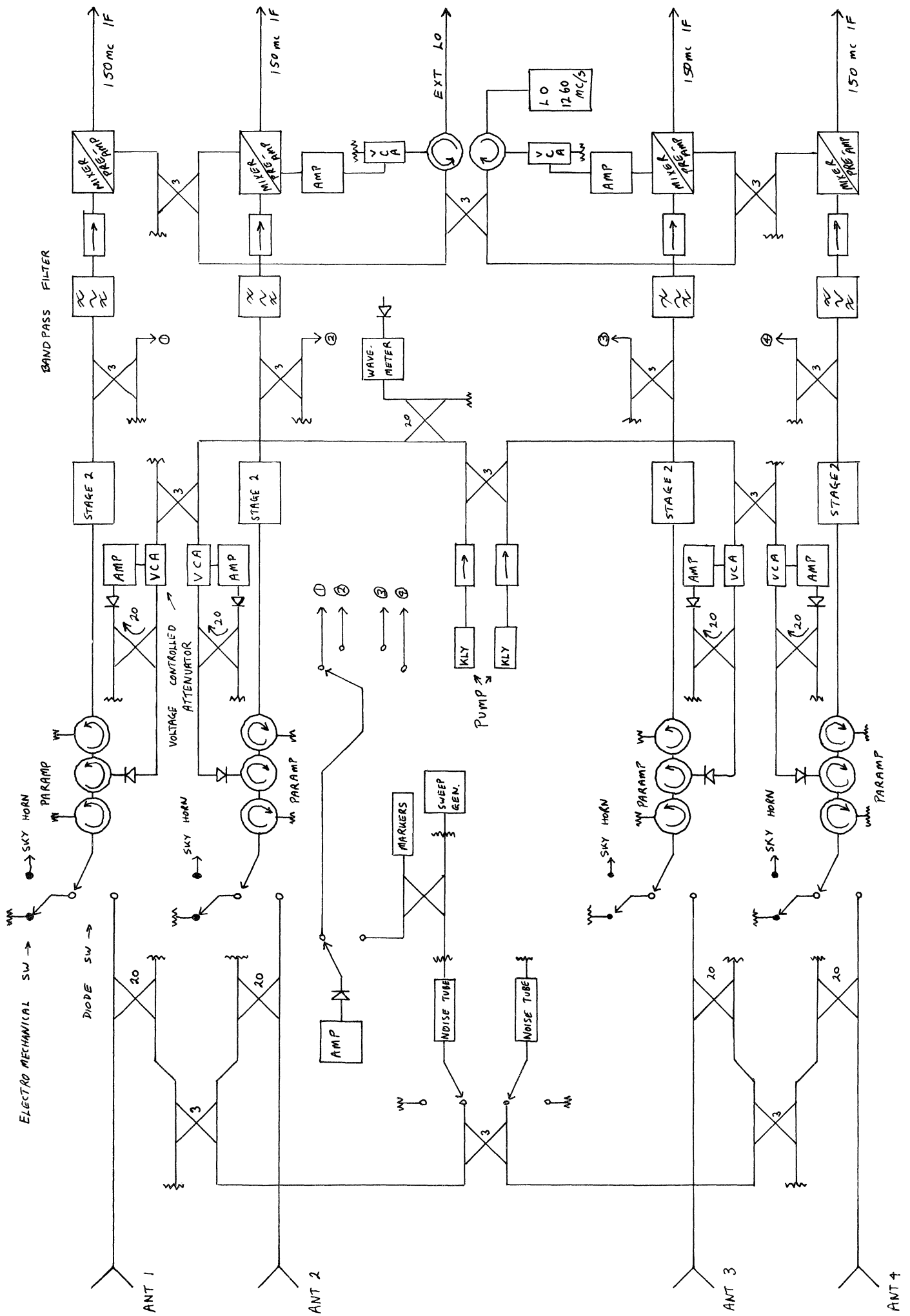

PROPOSED 4 CHANNEL 1420 mc/s RECEIVER

Feb 6 1967
M. Balinder