

Submillimeter Astronomy in France

P. ENCRENAZ

Laboratoire de Radioastronomie Millimétrique

OBSERVATOIRE DE PARIS - Section de Meudon

92195 - MEUDON FRANCE

ABSTRACT:

Submillimeter astronomy has been selected as the top priority for the next decade by the french space agency (CNES). A balloon borne telescope of 2m of diameter is built by Matra-Space, using the lightest CFRP materials. The petals of the telescope have been recently delivered: the telescope will be diffraction limited at 150 μm , and the pannels will be adjusted during flight. A pointing accuracy of 5" is anticipated. The first flight from Sicily to Spain is scheduled for 1992 with a set of bolometers cooled to He₃. The first heterodyne receiver will fly in 1993. It consists of a cooled schottky receiver at 380 GHz to observe simultaneously H₂O and O₂. The trilayer Nb/Al₂O₃/Nb junctions may be used for the first flight.

In collaboration with Cal Tech and Jet Propulsion Laboratory, a proposal for a small submillimeter satellite called SM₃ (T. Phillips in the P.I) has been selected for a phase A by CNES. Related technological developments are funded in the area of cryo coolers, adjustable pannels in flight, quantum well devices and local oscillator sources, and manufacturing of SIS junctions.

Work on different subsystems of the cornerstone FIRST is also in progress.

PRONAOS :

A French Balloon - Borne Space Project

1) Generalities :

PRONAOS is a scientific space project for astrophysical observations in submillimeter wavelength region with instrumentation borne on a stratospheric balloon gondola.

The PRONAOS architecture consists of three parts :

- a carry away vehicle : the stabilized gondola
- a common facility : the submillimeter telescope
- a scientific payload : 2 focal plane instruments

A 900 000 m³ balloon will permit first flights in transmediterranean campaigns from Sicilia to south Spain (about 20 hours of ceiling at an altitude of 40 km and a latitude of 38° N), in july 1992 and 1993.

2) "Naps" gondola :

The main characteristics of the vehicle are :

- an azimuthal gondola with two stages stabilization delivering a diurnal pointing with an accuracy RMS in arc seconds on two axes :
 - . absolute 7"
 - . stability 5"
 - . drift rate 5" (1 hour)
- the dry mass is 1600 kg for a launching mass of 2200 kg
- the mass of the pointed set including Telescope, 1 focal-plane instrument and various equipments is approximately 500 kg.
- The gondola dimensions are typically : 4m x 4m x 7m (see Fig III-1.1 and 1.2) and the on-board energy permits a capacity of 30 kWh by a set of lithium batteries.

PRONAOS NAPS - TEL

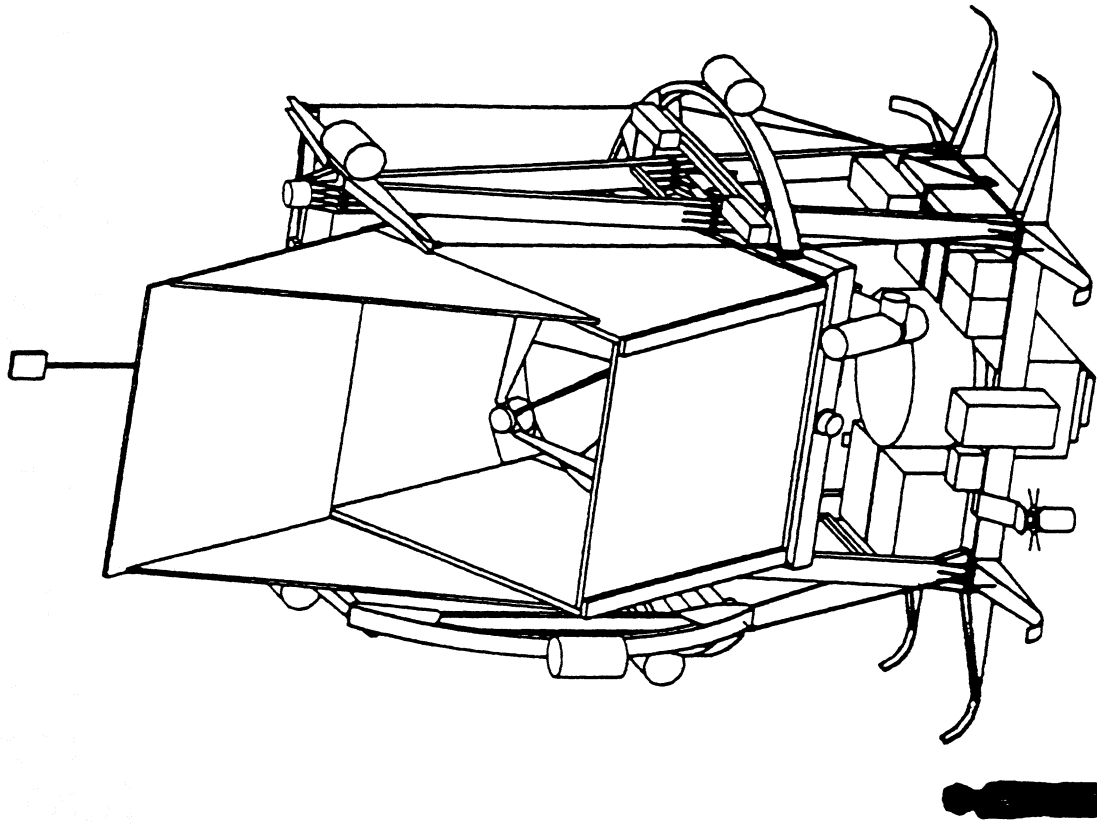
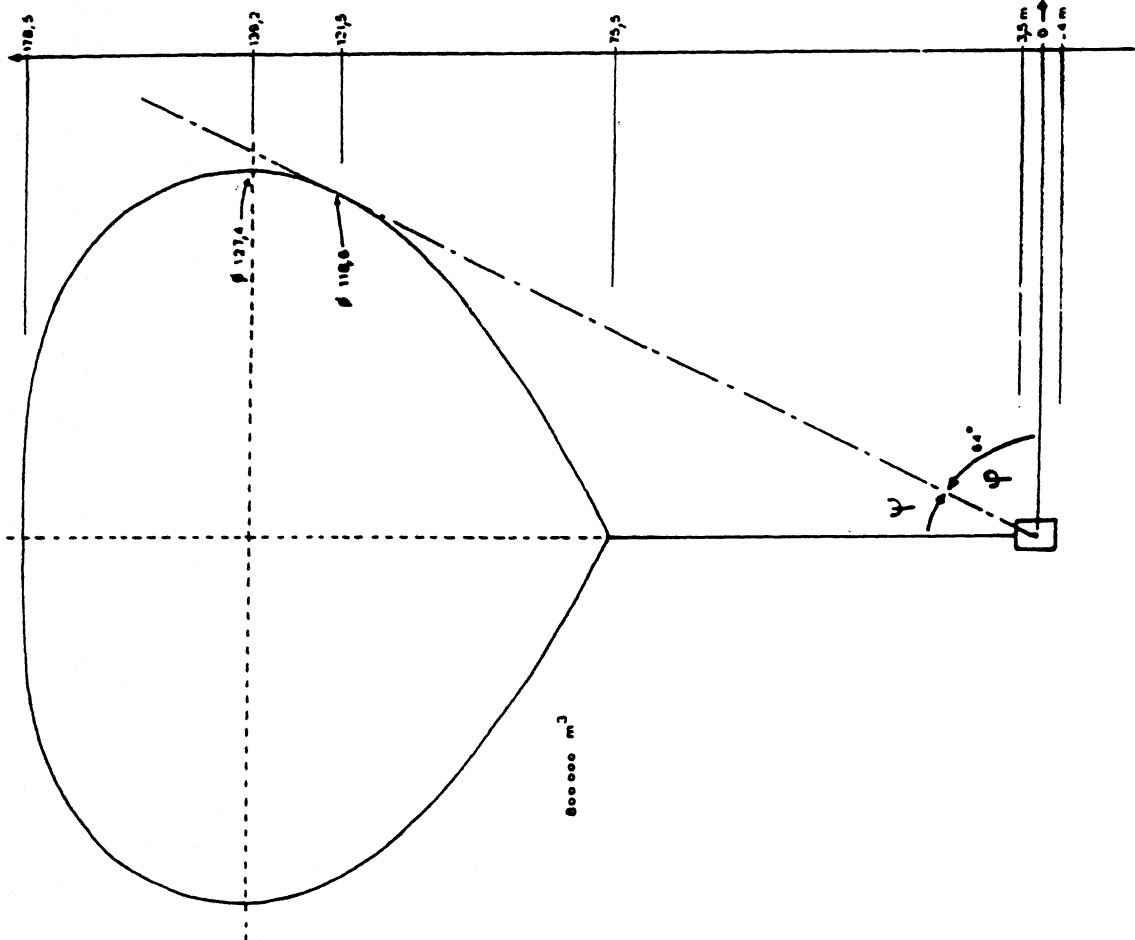

Fig III - 1-2

FIG II - 1 - 1 : ENSEMBLE MACTELLE ET BALLON

3) The telescope :

It is a 2m class submillimeter telescope. The main characteristics are :

Cassegrain type telescope with a focal length of 20m, with f/0,9 primary aperture and 2.8 m back focus. The pointing (accuracy goal : 5 arc second) is obtained by stellar sensor.

The 2m of diameter primary mirror has a surface accuracy of 10 μm RMS including all defects.

The image quality of the telescope will be limited by the diffraction at 300 μm .

Light weight technology is used for the primary mirror realization : carbon fibre by a replica-technique.

The mirror, segmented in 6 parts semi-active (in flight, alignment of the 6 segments considered as rigid, controlled by an on-board servo-loop), is equipped with 18 actuators and 30 displacement captors.

Each segment is realized in composite structure (carbon fibre : honeycomb and skins) on a replica mould : the mass is 3.3 kg, with a coating of 0.15 μm thickness gold deposit.

4) Instruments :

Two instruments could be used on the focal plane of the telescope :

SPM : (Multiband Photometric System)

The spectral resolution $\nu/\Delta\nu$ is 1 to 10 on the field : 200 μm to 1.5 mm (in 5 bands).

The photometer employs cooled bolometers at 0.5 K (or 0.1 K).

SMH : (Heterodyne Spectrometer)

With a high spectral resolution ($\nu/\Delta\nu \approx 10^6$)

The submillimeter heterodyne radiometer will operate in the first generation at 380 GHz with a next goal of operating to 550 GHz. Noise temperatures as low as 500 K at the lower frequency and 1000 K at the high end of the frequency range are expected. The heterodyne radiometer mixes the input signal with a local oscillator (LO) signal at approximately the same frequency to generate an output at the difference or intermediate frequency (IF) which is then amplified and processed.

An ambient thermal load and a cold load will be used for absolute calibrations of the radiometer. The mixer subsystem consists of a cooled Schottky diode, or three element array of superconducting - insulating - superconducting tunnel junctions (SIS)

operating at 3.5 K. The IF subassembly includes the cooled low-noise preamplifiers which are followed by warm amplifiers. The LO subsystem contains the injection optics, a set of frequency multipliers, Gunn oscillator to drive the multipliers, and a phase locking system for the Gunn oscillator.

Acousto-optic spectrometers (AOS) will be used for the spectral analysis of the heterodyne radiometers. The instrument block diagram is shown in Fig. III-2. Following are descriptions of the heterodyne radiometers and the AOS.

5) SMH main characteristics and description :

The first interstellar molecules in galactic sources studied with SMH are H_2O and O_2 at 380.2 and 368.5 GHz respectively.

Atmospheric attenuation for different sites, shown on Fig. III-3, indicates the necessity to observe from space.

Using the double side band operation on the submillimeter heterodyne receiver, both lines will be observed simultaneously by a optimized choice of the intermediate frequency of the receiver (see picture below) :

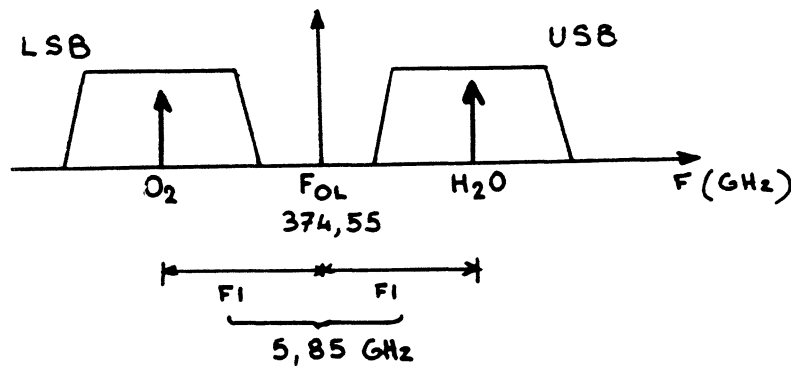

Sensitivity of the instrument : is given by the choice of the mixer technology. At first a cooled Schottky diode followed by an HEMT 6 GHz amplifier will be used. In this case a over-all 500 K noise temperature will permit to detect a line in half of hour. For the second flight, an SIS mixer will be used to increase the sensitivity.

Local oscillators :

Optimum performance of a Schottky or an SIS mixer is achieved with an absorbed LO power of about $300 \mu\text{W}$ in the first case or less $10 \mu\text{W}$ in the second case. To provide

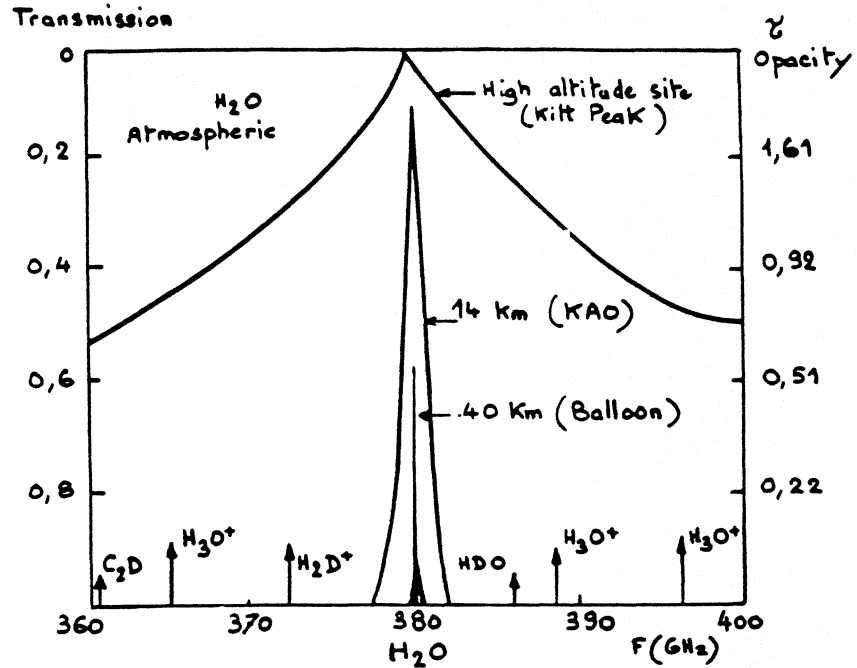
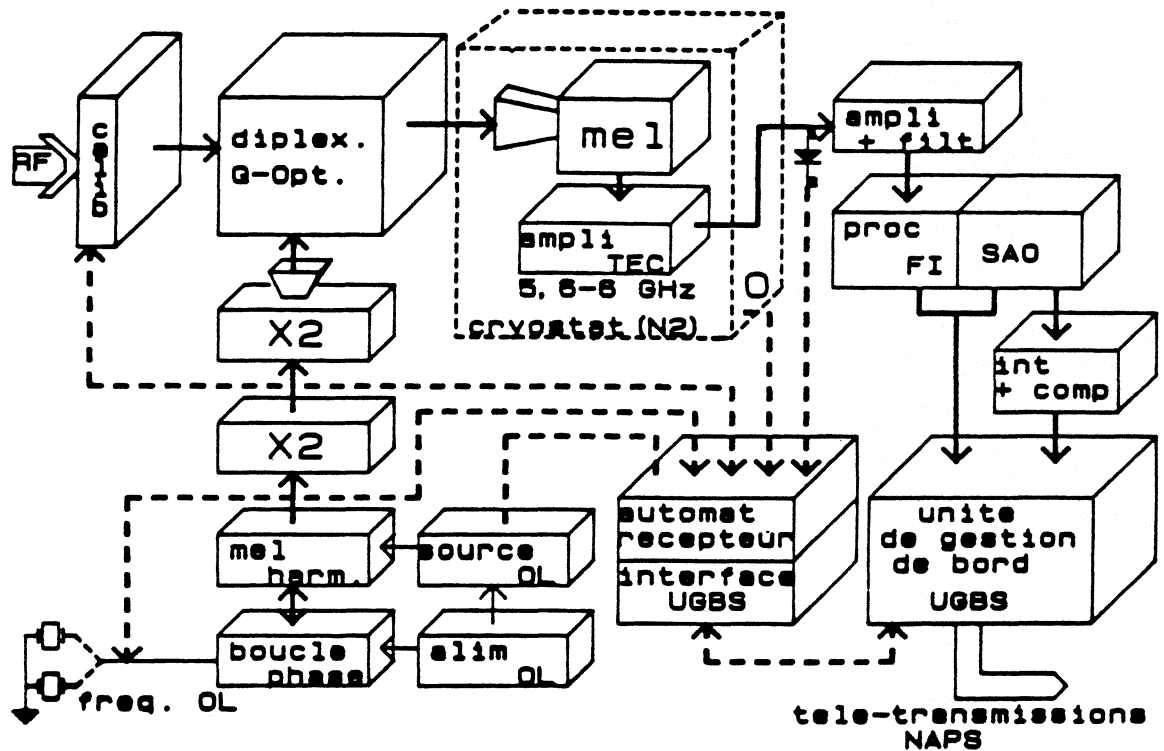

Fig III - 3 .

Atmospheric transmission



PRONACS/SMH - synoptique du recepteur -

Fig III - 2

even this level of power over the 300 GHz band is a challenge ; however, an approach based on frequency multiplication of phase-locked solid-state millimeter-wave sources is adequate and should be sufficiently reliable for space applications.

IF amplifiers :

The IF frequency will be set at about 6 GHz with a bandwidth of 500 MHz . To take advantage of the low noise performance of the mixers devices, the first IF stage, with 30 dB gain, will be cooled to about 40 K and located close to the mixers. HEMT devices are being developed in the frequency range with noise temperatures less than 20 K and low power dissipation.

Spectrum analysis :

Acousto-optic spectrometers (AOS) will be used to analyze the spectra from the heterodyne radiometers. In the AOS, the IF signal modulates a transducer which generates a beam of acoustic waves in a crystalline material. These acoustic waves diffract a separately injected laser beam. The deflected laser light is then detected by a linear array of photodiodes to integrate the signal power in each frequency channel. The signals from each diode are read out to a computer for the processing of the spectral data.

The spectrum resolution of 500 kHz with 1000 pixels is obtained by 2 acousto-optical spectrometers (Fig III-4). The AOS bandwidth is 180 MHz with a PbMoO₄ bragg cell.

To obtain high spectrum resolution, all local oscillators are stabilized by a phase and frequency loop on a quartz reference. (stability of 10^{-8} is required).

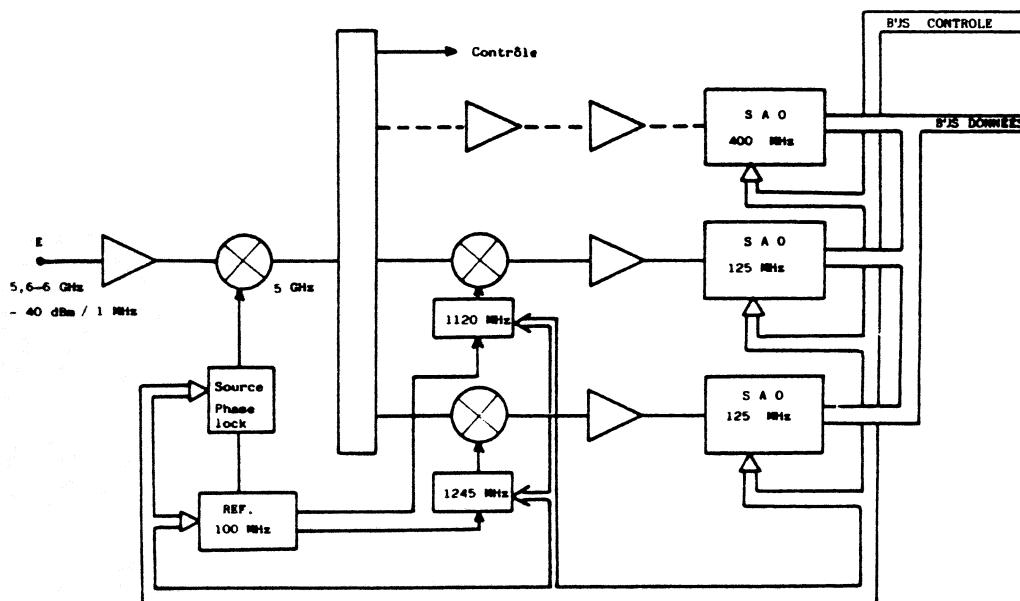
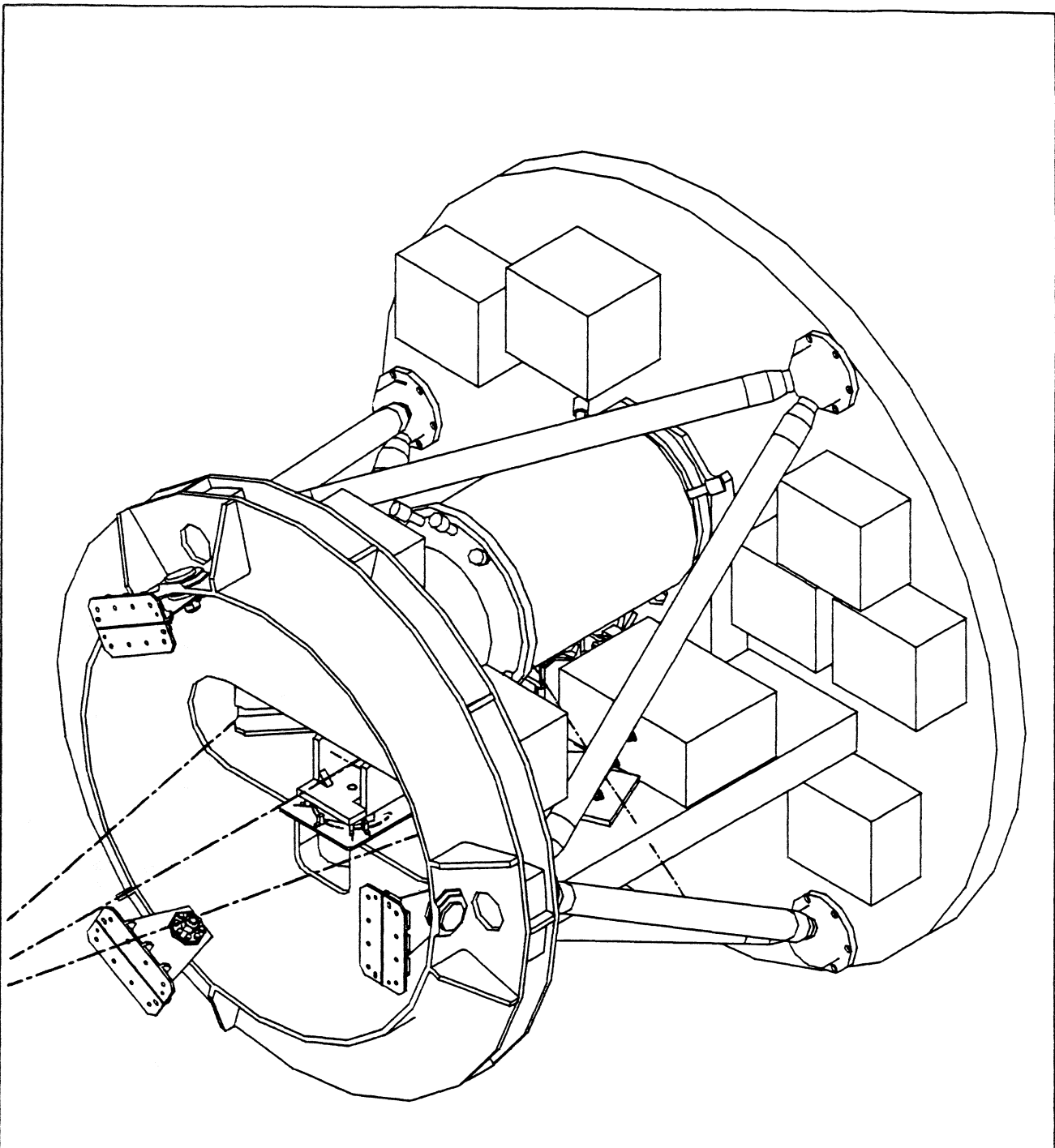

FIG. III-4

Data acquisition and controls : An in-board computer can control the receiver (house keeping) and compact the data to send them to the ground station. The transmission flow from the instrument is about 150 kbyte/s.

Cryogenics :

The constraints and requirements for the cryogenic system 3.5 K operating temperature with a 40 hours lifetime. The baseline design is a liquid Helium Dewar with a 40 K stage for the IF cooled amplifier.



DATES	VISAS	MODIFICATIONS			IND. ↑
USINAGE : 6.3		Matière :			
TRAITEMENT : ∇		POIDS :		ECH. : 1/15	
ARETES CASSEES : 0.25 à 45°		DATE : 23/4/90		DESSINE : MORIN	
TOLERANCES GENERALES : JS13- js13		DESIGNATION : PRONAS			
TEMPERATURE DE REFERENCE : 20° C		-XJ			
PROTECTION :					
OBSERVATOIRE DE PARIS-MEUDON					
S.E.R.T					

MATRA SPACE 

"FIRST" ANTENNA DEPLOYMENT

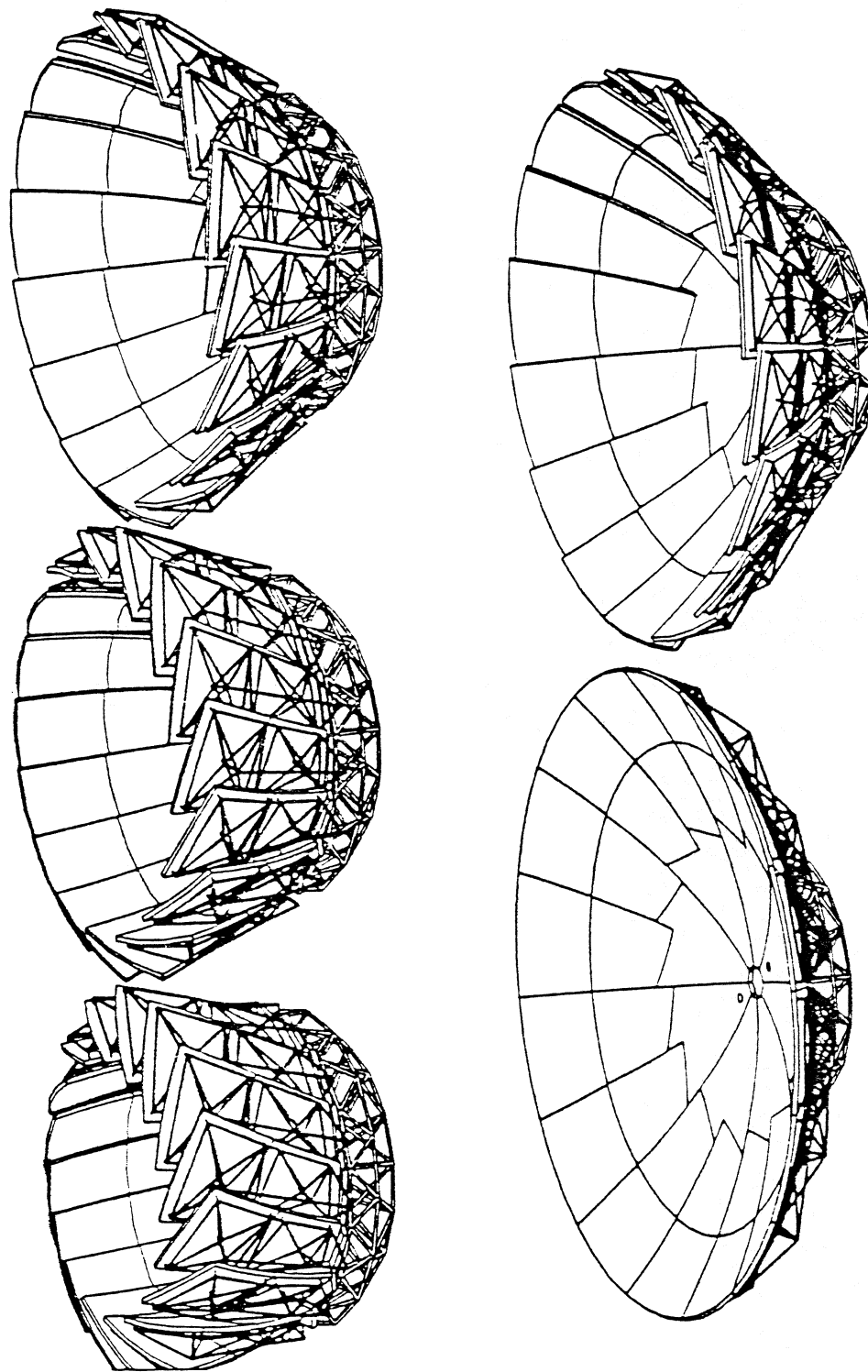

SUBMILLIMETER/INFRARED LINE SURVEY SPACECRAFT SYSTEM

LAUNCH CONFIGURATION*

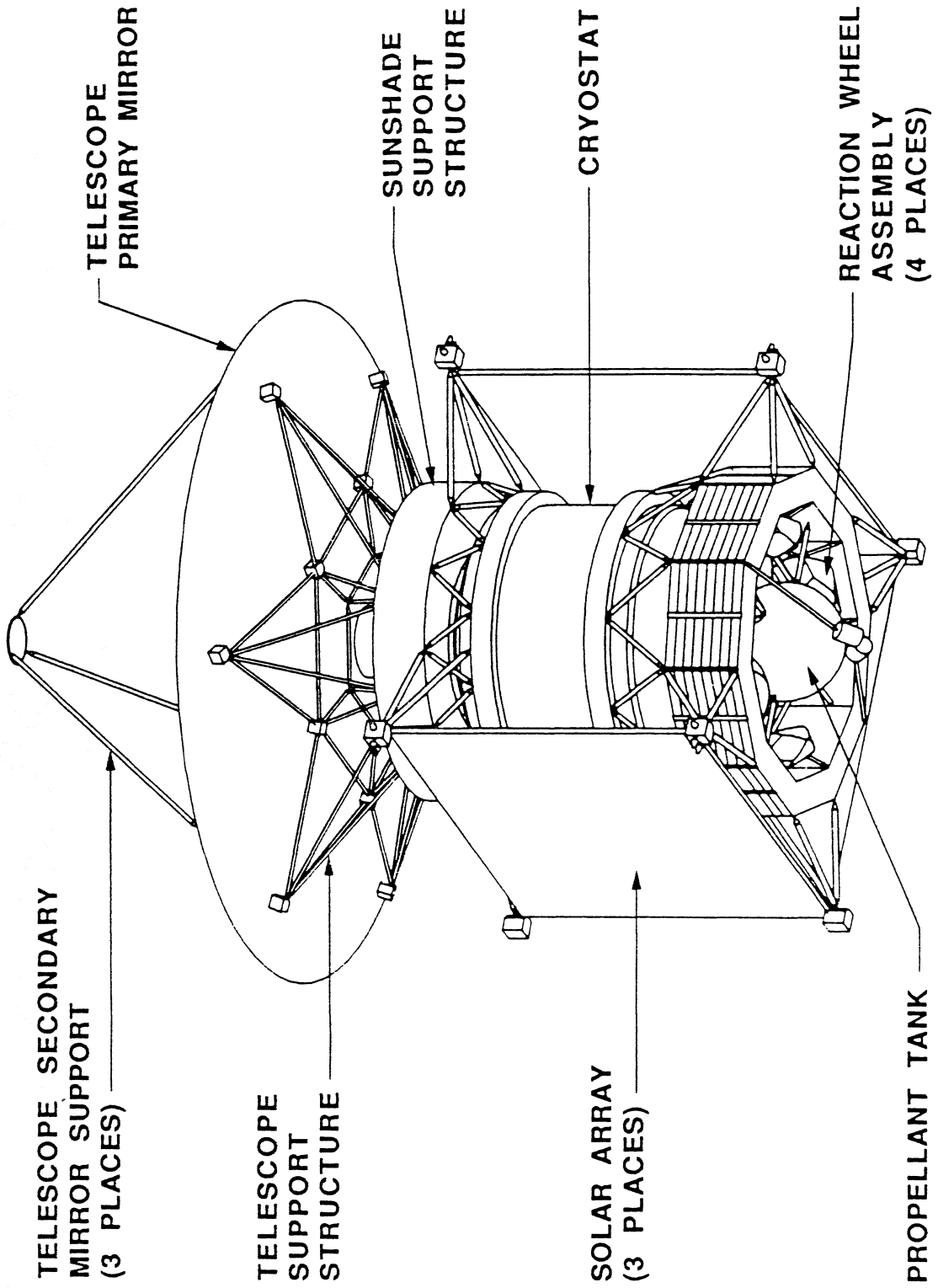

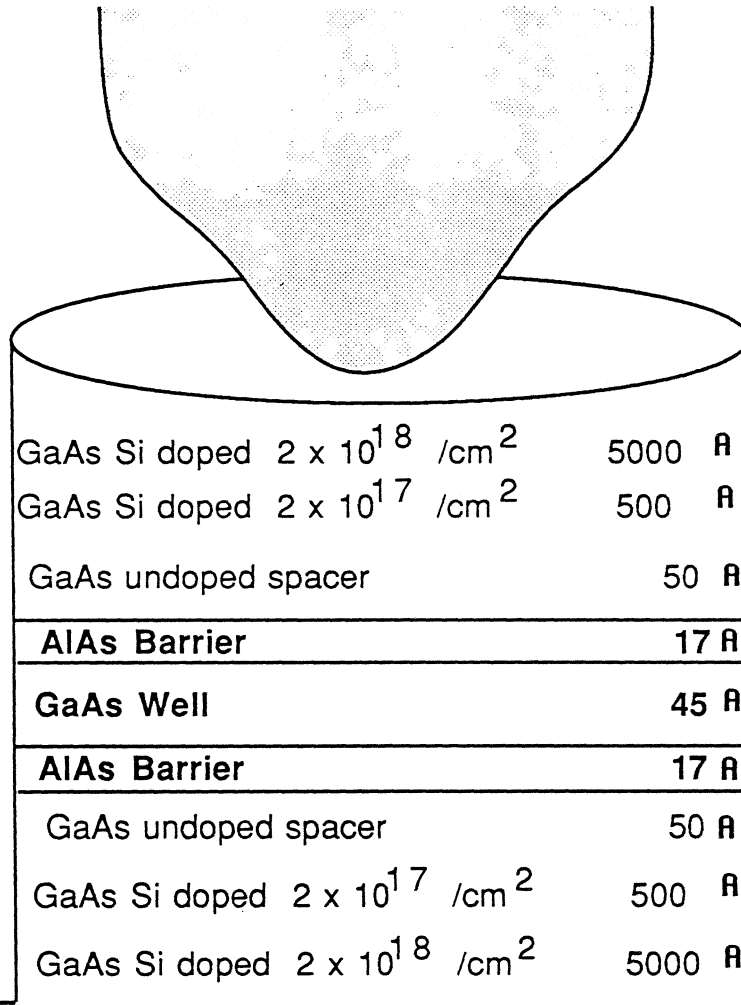

GaAs Substrate

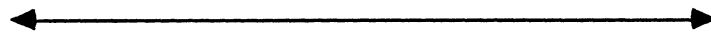

3 MICROMETERS

Resonant Tunneling Diode

AlAs/GaInAs Resonant Tunneling Diode

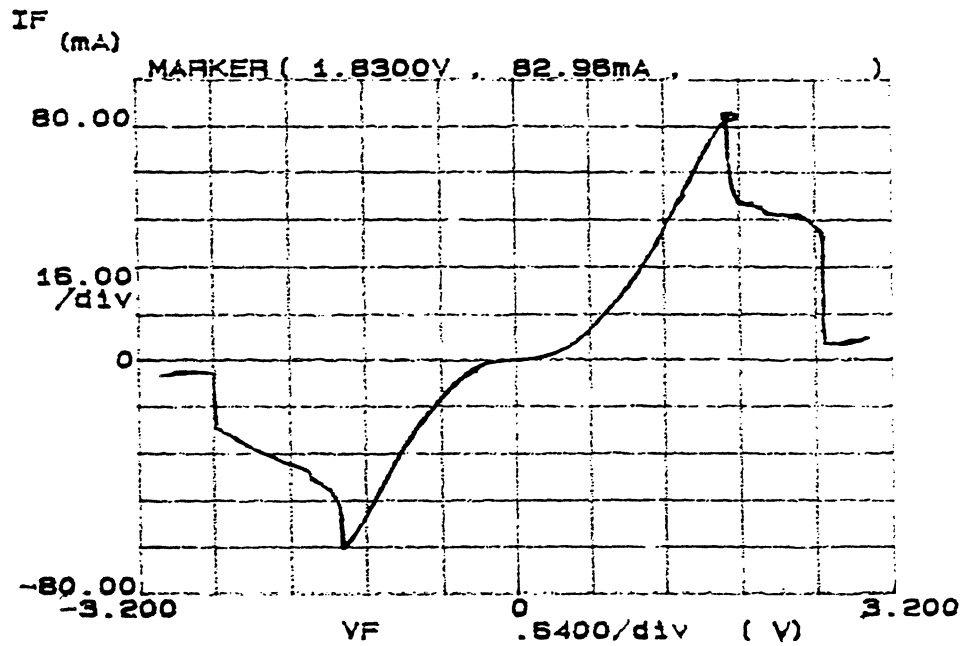

AlAs Barrier 25Å
GaInAs Well 50Å

Room Temperature
30 μm X 30 μm area

$$300\text{K} \frac{J_p}{J_v} = 15.8, J_p = 9.1 \text{ KA/cm}^2$$

at 77K 80 μm X 80 μm area

$$\frac{J_p}{J_v} = 37.5, J_p = 7 \text{ KA/cm}^2$$

Ecole Polytechnique Federale de Lausanne
Thomson CSF-LCR
Ecole Normale Supérieure

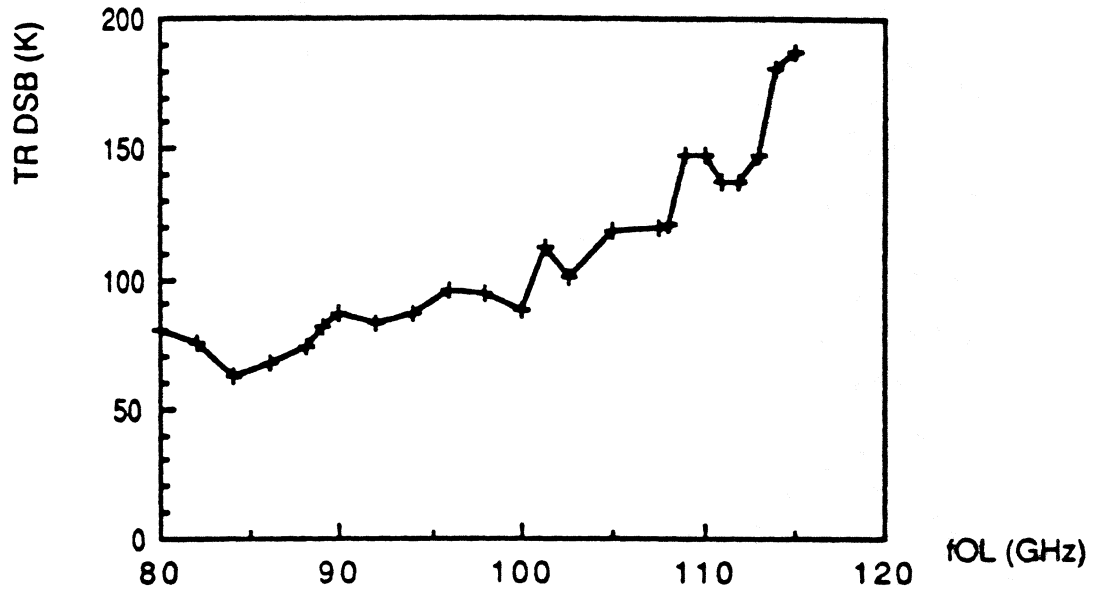

Fig.4. Receiver noise temperature (DSB) with the $2\mu\text{m}^2$ all Nb junction as a function of LO frequency.

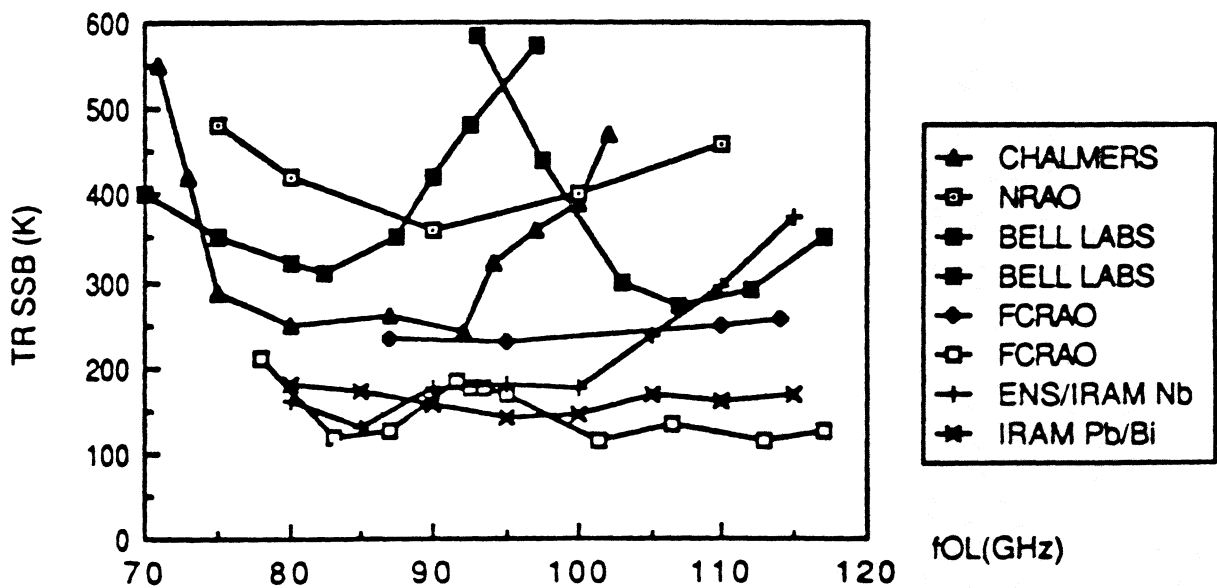

Fig.5. Frequency response of 3-mm cooled mixers. Single sideband receiver noise temperature are plotted over the 70 to 120 GHz range for the NRAO mixer, the Bell Telephone Laboratory system, the Chalmers University system and the Five College Radio Astronomy Observatory Schottky receiver (after (20)). Also shown on this figure the data obtained with IRAM receiver using Nb/Al-AIOx/Nb junction and Pb/Bi junction. Filled symbol are SSB temperature and the others are twice DSB results.

MATRA SPACE

4 METERS SBMM SEGMENTED MIRROR TENTATIVE BASELINE

- . SEGMENTATION GEOMETRY :
 - . HEXAGONAL 19 SEGMENTS
- . SEGMENTS :
 - . MADE OF CFRP : UHM GY70/PITCH 100S 2 SKINS ISOTROPIC LAYUP DISTANCIATED BY CFRP HONEYCOMB CURED ON ZERODUR GLASS MOLD (X3)
 - . OPTICAL SURFACE OBTAINED BY REPLICA TECHNIQUE TH = 0.1 MM
- . REFLECTIVE COATING :
 - . VACUUM DEPOSITION OF GOLD TH = 0.15 MICRON
- . SUPPORTING ACTUATORS :
 - . 3 PER SEGMENT - TOTAL NUMBER : 57
 - STEPPER MOTOR ASSOCIATED TO GEAR REDUCTION AND SPINDLE RESOLUTION : 0.1 MICRON
- . INTER-SEGMENT SENSORS :
 - . 12 PER SEGMENT - TOTAL NUMBER : 84
 - . CAPACITIVE TYPE - DIFFERENTIAL MEASUREMENT
 - . ELECTRODES MADE IN ZERODUR/GOLD COATED RELATIVE TYPE.
- . CONTROL :
 - . RELATIVE TYPE
 - . SURFACE ACCURACY OF THE MIRROR KEPT BY MINIMIZING THE DEVIATION OF SENSORS INFORMATIONS WRT REFERENCE VALUES.

MATRA SPACE

4 METERS - SBMM SEGMENTED MIRROR SURFACE ACCURACY BUDGET

<u>CONTRIBUTORS</u>	<u>ALLOCATION (RMS IN MICRON)</u>
<u>A/ CRFP SEGMENTS MANUFACTURING :</u>	
A1-SEGMENT DEVIATION WRT BF PARABOLA	1,5
A2-SEGMENT RADIUS OF CURVATURE SCATTERING	1,5
<u>B/ SEGMENTS DIMENSIONAL STABILITY</u>	
B1-THERMAL (WORKING T : 100K -50 K+ 10K . DIAMETRAL GRADIENT = 5K . TRANSVERSAL GRADIENT = 3K)	1,0
B2-MOISTURE RELEASE	2,3
B3-GRAVITY RELEASE	0,5
B4-LACK OF ISOSTATICITY OF SEGMENT FIXATIONS	0,2
<u>C/ STABILITY OF SUPPORTING STRUCTURE (BETWEEN 2 CORRECTIONS)</u>	
	0,1
<u>D/ SEGMENTS INITIAL ALIGNMENT ACCURACY</u>	
	1,0
<u>E/ CONTROL LOOP ACCURACY</u>	
	1,0

$$F/ \text{TOTAL} = \left[A1^2 + A2^2 + (B1 + B2 + B3 + B4)^2 + (C + D + E)^2 \right]^{1/2} = 5,0$$

MATRA ESPACE

4 METERS SBMM SEGMENTED MIRROR CONTROL ALGORITHM

- . GEOMETRY : 19 SEGMENTS
- . ACTUATORS : 3 x 19 = 57 POSITIONS OF THEM ARE DEFINED BY A VECTOR P
- . SENSORS : 12 PER SEGMENT - TOTAL NUMBER = 84 - ALL OF THEM WORKING IN DIFFERENTIAL
(MONITORING OF RELATIVE POSITION OF ASEGMENT WRT ADJACENT ONES.
SENSOR INFORMATIONS ARE DEFINED BY A VECTOR Z
- . GEOMETRY OF THE SYSTEM == > INFLUENCE MATRIX M == > Z = M.P
- . RECIPROCALLY Z BEING THE SENSORS INFORMATIONS ASSOCIATED TO NOISE COVARIANCE
MATRIX : N
- . ALGORITHM WILL DERIVE P VECTOR MINIMIZING THE VARIANCE

$$\text{MIN} \left[{}^T (Z - MP) N (Z - MP) \right] == > {}^T M.N^{-1} \quad M.P = M.N^{-1} \cdot Z$$
- RIGID BODY MOTIONS OF THE MIRROR IS NOT DETECTED BY THE SYSTEM

$$== > {}^T M.N^{-1} \quad M \quad \text{IS SINGULAR (ORDER 3)}$$
- SELECTED SOLUTION == > PISTON AND TILTS = 0 == > P = CZ

MATRA SPACE

4 METERS - SBMM SEGMENTED MIRROR CONTROL LOOP ACCURACY BUDGET

CONTRIBUTORS	SURFACE ACCURACY DEGRADATION (RMS IN MICRONS)
. SENSORS AND ASSOCIATED ELECTRONIC ACCURACY	0,2
. STABILITY OF DISTANCE SENSOR/OPTICAL SURFACE	0,2
. STABILITY OF BEST PLANE/SENSORS PLANE	0,2
. ALGORITHM ACCURACY	0,2
. ACTUATORS ACCURACY	0,2
TOTAL (LINEAR SUMMATION)	1,0

MATRA SPACE

4 METERS SBMM SEGMENTED MIRROR MASS/POWER BUDGETS ESTIMATE

<u>MASS</u>	<u>POWER</u>	<u>PEAK STAND BY</u>
. SEGMENTS (19) :	47.5 KG (2.5KG/SEGMENT)	SENSORS ELECTRONIC 60 W 160 W
. ACTUATORS (57) :	34.2 KG (0.6 KG/ACTUATORS)	ACTUATORS <u>30 W 30 W</u>
. SENSORS (84) :	21.0 KG (0.25KG/SENSOR)	190W 160W
. ELECTRONICS :		
. SENSORS	10.0K6	
. ACTUATORS :	7.0KG	
. HARNESS :	13.0KG	
. CONTINGENCY :	<u>12.0KG (9%)</u>	ASSUMPTION :
	144.7KG	ACTUATORS DRIVEN
		BY GROUP OF 3 (TBR)
. SURFACIC MASS	11.5KG/M2	
. GOAL	10 KGM2	

MATRA ESPACE

4 METERS SBMM SEGMENTED MIRROR SURFACE ACCURACY MIRROR

<u>CONTRIBUTORS</u>	ALLOCATION	PERFORMANCE ESTIMATE	REMARKS
A/ CFRP SEGMENTS MANUFACTURING			
A1/ SEGMENT DEVIATION WRT BF PAROBOLA	1.5	1.5	PER = SPEC
A2/ SEGMENT RADIUS OF CURVATURE SCATTERING	1.5	1.5	
B/ SEGMENT DIMENSIONAL STABILITY			
B1/ THERMAL (WORKING TEMP T = 100K - 50K + 0K DIAM GRAD = 5K/TRANS GRAD 3K)	1.0	0.84	CORRESPONDING TO ISO TYPE ORBIT
B2/ MOISTURE RELEASE	2.3	0.12	
B3/ GRAVITY RELEASE	0.5	0.22	
B4/ LACK OF ISOSTATICITY OF SEGMENT FIXATIONS	0.2	0.14	
C/ STABILITY OF SUPPORTING STRUCTURE	0.1	0.1	PERF = SPEC
D/ SEGMENTS INITIAL ALIGNMENT ACCURACY	1.0	1.0	
E/ CONTROL LOOP ACCURACY			
E1/ SENSOR & ASSOCIATED ELECTRONICS	0.2	0.05	SENSOR ALONE = +/- 25 nm
E2/ STABILITY OF DISTANCE SENSORS/OPTICAL SURFACE	0.2	0.2	
E3/ STABILITY OF BEST PLANE/SENSORS PLANE	0.2	0.2	
E4/ ALGORITHM ACCURACY	0.2	0.2	
E5/ ACTUATORS ACCURACY	0.2	0.065	ACTUATOR ALONE = +/- 0.05 micron
TOTAL = $\left[A1^2 + A2^2 + (B1 + B2 + B3 + B4) + \frac{1}{(C + D + E1 + E2 + E3 + E4 + E5)} \right]^{1/2}$	5	3.1	