

A PLANAR QUASI-OPTICAL SIS RECEIVER FOR ARRAY APPLICATIONS

Philip A. Stimson, Robert J. Dengler, Peter H. Siegel and Henry G. LeDuc

Jet Propulsion Laboratory, Pasadena, CA, 91109

Abstract—A novel planar, quasi-optical SIS receiver operating at 230 GHz is described. The receiver consists of a 2×5 array of half wave dipole antennas with ten niobium–aluminum oxide–niobium SIS junctions on a quartz dielectric-filled parabola. The 1.4 GHz intermediate frequency is coupled from the mixer via coplanar strip transmission lines and 4:1 balun transformers. The receiver is operated at 4.2 K in a liquid helium immersion cryostat. We report here accurate measurements of the performance of single receiver elements. A mixer noise temperature of 89 K DSB, receiver noise temperature of 156 K DSB and conversion loss of 8 dB into a matched load have been obtained.

INTRODUCTION

The quasiparticle superconductor-insulator-superconductor (SIS) mixer is the most sensitive detector in the millimeter-wave region and forms the basis of most high quality receivers for millimeter-wave astronomy [1]. The quantum limit for noise temperature (in a SSB mixer) has essentially been reached at 100 GHz [2] [6], but at higher frequencies the available performance is poorer, with 10 times the quantum limit being a more realistic goal. This figure has recently been reported from the best waveguide mixers around 200 GHz [3] [4] [5]. The major cause of the performance reduction at high frequency is the SIS junction capacitance, which presents a smaller parallel reactance and shunts the quasiparticle response. Tuning structures can, in principle, alleviate this limitation but are not yet well understood at higher frequencies [8]. The approach most often used, and that used here, is to fabricate high current density junctions with exceedingly small areas ($< 1 \mu\text{m}^2$) to reduce the capacitance. Another serious problem is control of Josephson currents in the junction. Noise temperatures obtained with broadband hot and cold loads may be highly inaccurate in the presence of Josephson currents. These effects become more important as the frequency and/or bandwidth is increased. Other

problems include losses in conductors and dielectrics, the fabrication difficulties of small waveguide components and difficulties in obtaining convenient local oscillators.

Quasi-optical receivers with planar circuit mixers are an attractive approach for systems at frequencies in the neighborhood of 1 THz [7] [8] [9]. They suffer the disadvantage of being fixed tuned but provide the advantage of convenient monolithic fabrication. Planar configurations are also a desirable approach to realizing array receivers.

In this paper, we report accurate measurements on a quasi-optical array-type receiver at 230 GHz. We have been able to suppress Josephson currents almost completely, and our intermediate frequency versus bias voltage curve exhibits the smooth oscillatory behavior of the best waveguide mixers [3]. Our configuration is designed to allow an array of mixers to be measured during one cool down cycle. We report here the performance of a single array element. We will report on complete array performance in a separate paper. The SIS junctions used for these experiments were nominally identical to those used in recent waveguide receivers [3] [4], with which our results may be compared.

SIS JUNCTION FABRICATION

The junction wafer used for this receiver carries a 2×5 array of resonant dipole antennas with $0.4 \times 0.4 \mu\text{m}$ niobium–aluminum oxide–niobium SIS junctions at the terminals. The junctions were fabricated using a self aligned lift-off trilayer process. The niobium–aluminum oxide–niobium trilayer was sputtered onto the 0.25 mm thick, 17 mm diameter quartz substrate through a photoresist stencil. The trilayer remaining af-

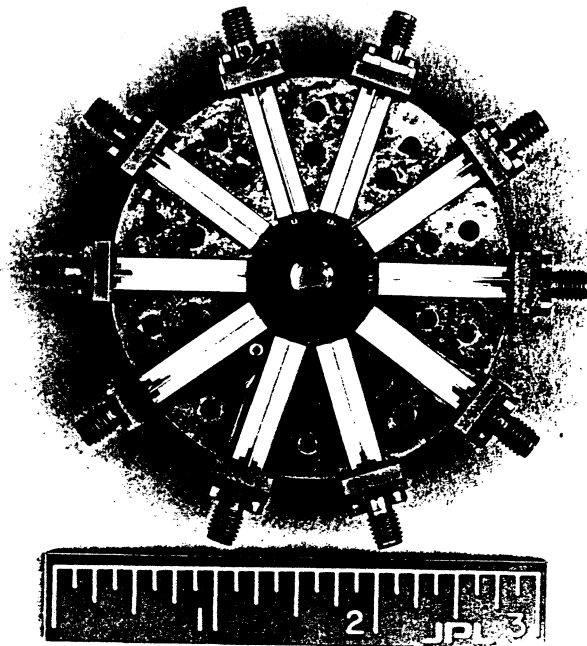

Fig. 1. The mixer block with the upper half removed. The central dielectric-filled parabola (dark), containing 10 antenna and mixer elements, is surrounded by 10 IF baluns (light) and SSMA connectors at the edge of the block.

ter lift-off formed half of each antenna and the ten coplanar strip transmission lines used for the IF. The junction mesa was patterned using electron beam lithography on 1200 Å thick PMMA over a 4000 Å thick polyimide layer, followed by evaporation of 500 Å of chromium metal and lift-off. The chromium stencil was transferred to the polyimide underlayer by reactive ion etching in an oxygen plasma. The contact regions of the trilayer were then protected with a resist stencil and the chromium/polyimide mask was used to etch the junction. Thermal SiO was deposited using the same stencil to provide electrical isolation of the base electrode and to provide dielectric for two RF blocking capacitors located one quarter and three quarter wavelengths away from the junction down the coplanar strips. The polyimide was then removed with dichloromethane. The second half of the antennas was made by deposition of niobium and reactive ion etching.

RECEIVER DESIGN

The mixer block, shown in Figure 1, consists of the junction/antenna wafer, a quartz reflector, and IF baluns and connectors mounted in a brass housing. The wafer is held on the flat face of a quartz parabolic lens, whose rear surface is metalized. Incoming radiation is reflected by the metal surface and focussed onto the antenna elements at the center of the wafer. The configuration, called a Dielectric-Filled Parabola (DFP), is analogous to a conventional parabolic dish antenna. The IF signals are coupled from the wafer via coplanar strip transmission lines. Monolithic IF baluns transform the 200 Ω characteristic impedance of the coplanar strips to that of 50 Ω coaxial transmission line. Details of this design, including extensive low frequency modeling, are described by Siegel et al. [10] [16]. A superconducting magnetic field coil is mounted on the block to suppress Josephson currents in the junctions.

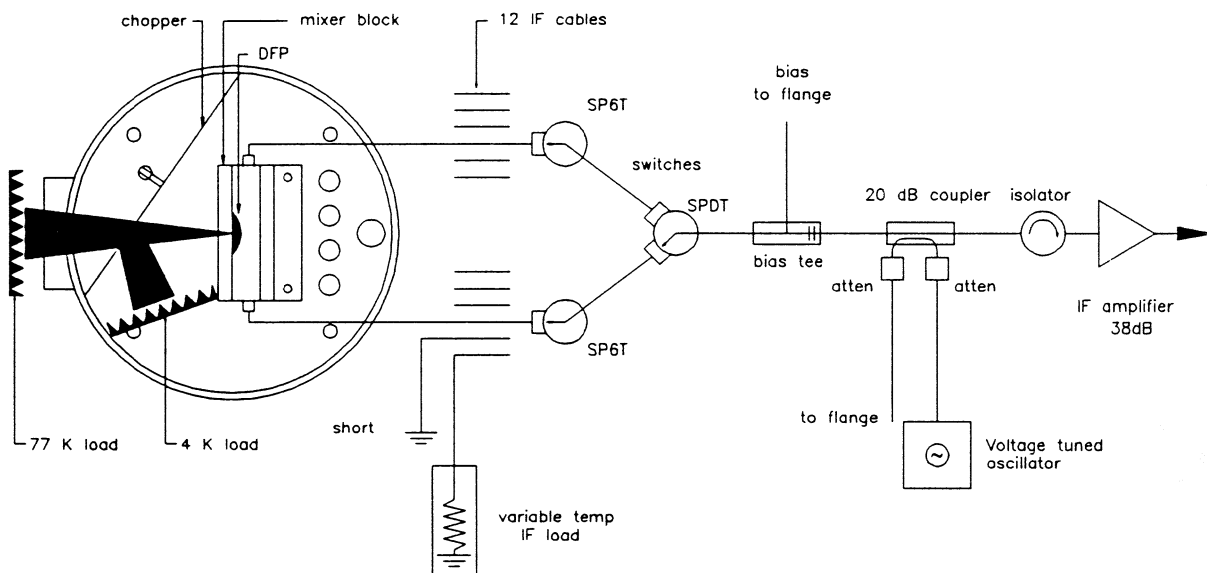

Fig. 2. Schematic diagram of the IF system of the array receiver. The entire system is immersed in liquid helium except for the 77 K load which is bolted to the liquid nitrogen shield of the cryostat.

The IF system shown in Figure 2, consists of ten IF cables routed through two 6-position coaxial switches and one 2-position switch to a single amplifier chain. The remaining two switch positions are used to connect a short and a variable temperature IF load to the amplifier input. The load consists of a resistor terminating a stainless steel coax cable on a thermally isolated plate which contains a heater resistor and diode thermometer. The structure is enclosed in an indium sealed can. This permits accurate calibration of the IF system and very accurate mixer measurements [11]. An isolator is used to reduce the SWR at the amplifier input and a directional coupler with cooled attenuators allows signals to be injected into the IF system to measure the mixer reflection coefficient. After removal from the cryostat the IF signal is further amplified and passed through a variable center frequency 50 MHz wide filter and fed to a power detector. The IF system noise temperature is approximately 7 K at 1.4 GHz.

The optical system consists of a chopper mounted directly in front of the mixer, and the hot and cold loads. When the chopper blade is closed the input beam is directed onto a 4 K (cold) load mounted on the receiver plate; when it is open the beam passes through a quartz window to a 77 K (hot) load mounted on the liquid nitrogen shield of the cryostat. The loads are pyramidal absorbers manufactured from Eccosorb CR-110, which is known to provide high absorption and low reflection at this frequency. Reflection from a flat plate of CR-110 has been measured at less than -10 dB in this frequency range [12]. The window is exactly five wavelengths thick and passes almost all the incident 230 GHz radiation. The theoretical transmittance is 0.999; we measured a transmittance of over 0.95. Local oscillator radiation is produced by a Gunn diode and Schottky diode doubler and is injected through the back of the mixer block. No diplexer is required.

The entire receiver is immersed in liquid helium which eliminates heat sinking problems. The dielectric constant of the helium is 1.048 [15]. The switches, thermometers,

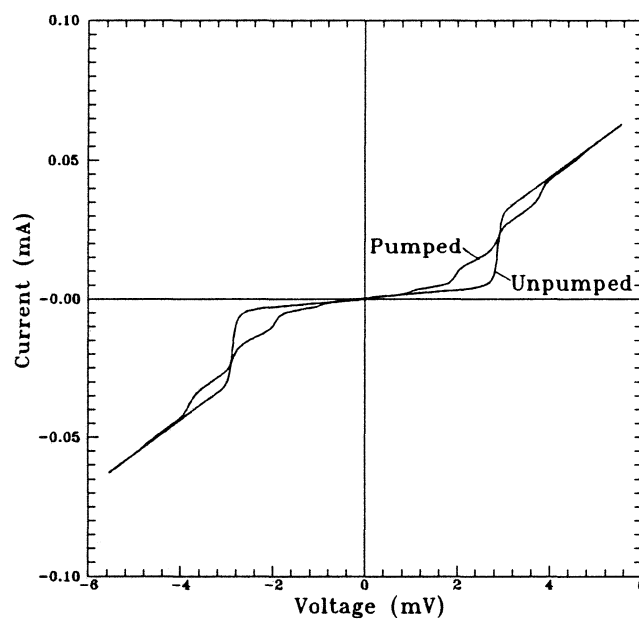

Fig. 3. Pumped and unpumped IV curves for a typical Nb-AlO_x-Nb SIS junction used in the planar receiver.

liquid level meter...etc., and all data acquisition is controlled by a computer.

MEASUREMENT TECHNIQUE

We use a variation of the technique of McGrath et al. [11], to obtain mixer gain and noise temperature. First, the IF system is calibrated by plotting the temperature of the IF load as a function of the IF output power. This measures the IF system noise temperature T_{IF} . The receiver noise temperature T_R is measured using the hot and cold loads (T_H and T_C), the ratio of the IF output powers $Y = P_{IFH}/P_{IFC}$ and Equation 1.

$$T_R = \frac{T_H - YT_C}{Y - 1} \quad (1)$$

$$T_M = T_R - \frac{(T_{IF} + T_S \Gamma^2)}{(1 - \Gamma^2)} L_M \quad (2)$$

$$\frac{1}{L_M} = \left(\frac{T_{IFH} - T_{IFC}}{T_H - T_C} \right) \left(\frac{1 - \gamma^2}{1 - \Gamma^2} \right) \quad (3)$$

Next, the temperatures of the IF load, T_{IFH} and T_{IFC} , which produce output powers P_{IFH} and P_{IFC} are calculated from the calibration, and the effective bath temperature T_S determined by measuring the power output from the IF system with a shorted input. The IF reflection coefficient of the mixer Γ (and of the load γ) is measured by injecting a signal from a voltage tuned oscillator through the coupler and recording the difference in reflection between the mixer and the short. The loss into a matched load and noise temperature are then calculated from Equations 2 and 3.

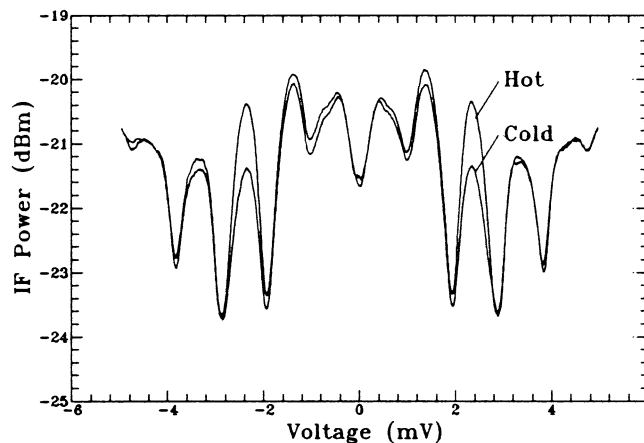

Fig. 4. IF output power as a function of bias voltage for hot and cold load inputs. The curve exhibits a smooth oscillatory behavior similar to that expected from theory with no sharp spikes or discontinuities indicating excellent control of Josephson currents.

RESULTS

Typical pumped and unpumped IV characteristics are shown in Figure 3, and IF output power as a function of bias voltage for hot and cold load inputs is shown in Figure 4. A superconducting magnet was used to suppress Josephson currents. The curve exhibits a smooth oscillatory behavior similar to that expected from theory [13] [14] with no sharp spikes or discontinuities. The IF output power is expected to decline towards zero bias; the fact that there is some power output at zero bias indicates some remaining Josephson currents which were not fully suppressed. These remain visible on the IF curve even though the IV curve appears smooth. Nevertheless, we believe that this is the best IF behaviour reported from a planar quasi-optical SIS receiver.

The most recent experiments performed with this receiver used junctions with an area of $0.2 \mu\text{m}^2$. The normal state resistance was 56Ω , the critical current density was 15 kAcm^{-2} and the ωRC product was approximately 1.3. The mixer and receiver noise temperatures and mixer conversion loss are plotted as a function of IF frequency in Figure 5. The LO frequency was 230 GHz. The best results are obtained at 1.35 GHz where a T_M of 89 K DSB, a T_R of 156 K DSB and conversion losses of 8 dB (into a matched load) were measured. The IF mismatch is approximately 1 dB across the IF band. Estimated uncertainties in the noise temperatures are $\pm 5 \text{ K}$, and in the loss, $\pm 0.5 \text{ dB}$. These values neglect any uncertainty due to RF load reflections or beam spillover. The largest Y-factor was obtained on the first quasiparticle step below the energy gap, at a bias voltage of approximately 2.3 mV. An inferior Y-factor was noted on the second step. The

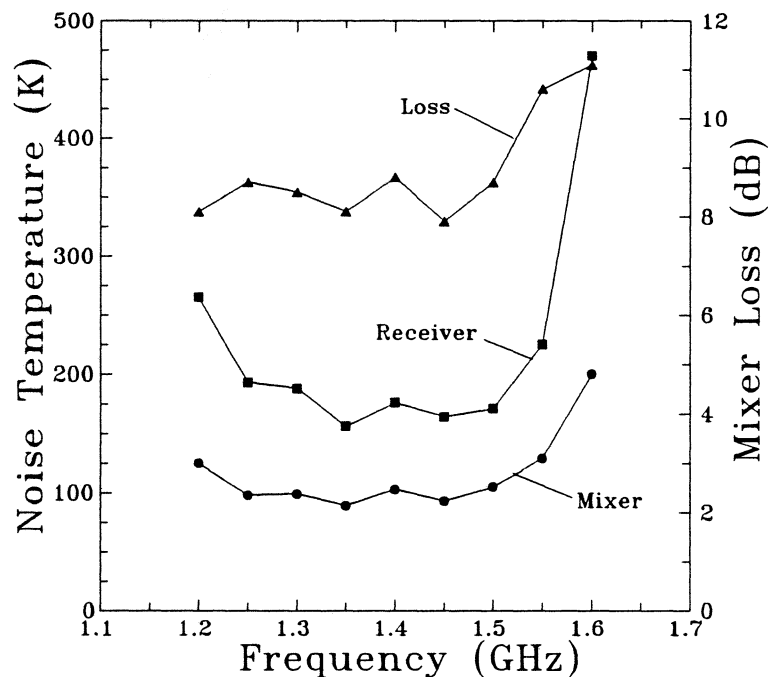

Fig. 5. Mixer and receiver noise temperatures and mixer loss as a function of IF frequency. The best results are obtained at 1.35 GHz where a T_M of 89 K DSB, a T_R of 156 K DSB and conversion losses of 8 dB were measured.

mixer noise temperature and conversion loss are seen to be essentially constant across the IF band. Mixer noise temperature is referred to the optically coupled loads at the system input and includes the effects of all components through to the IF connectors at the output of the balun transformers. The receiver noise temperature follows the noise behavior of the IF amplifier.

At each data point on the curves, the change in IF reflection coefficient, and the change in bias point, caused by switching between the hot and cold loads was measured. This is necessary to ensure that the observed Y-factor is not produced by different LO pumping conditions, or change in bias point when observing the hot and cold loads. Different pumping would be expected to change the junction output impedance and the IV curve shape. The reflection coefficient change was verified to be less than 1 %, and the change in bias voltage less than 0.02 mV. This indicates that the observed Y-factor has no appreciable component due to these factors.

Recent results from waveguide mixers at similar frequencies using junctions with similar specifications from the same fabrication process [3] [4] give mixer temperatures of 48 K DSB and 60 K SSB and conversion losses of 2 dB. Our noise temperature results, although a factor of two higher, are consistent with these values given the lack of tuning capability inherent in our planar circuit.

CONCLUSION

We have demonstrated a planar quasi-optical SIS mixer and low noise receiver which is suitable for array applications. Best performance of an individual element at 230 GHz was a mixer noise temperature of 89 K DSB, a receiver temperature of 156 K DSB and a conversion loss of 8 dB. The IF output shows a smooth variation with bias, indicating good control of Josephson currents. The noise results are consistent with recent measurements using similar junctions in waveguide receivers, and are only a factor of two higher. The conversion loss is rather large, but consistent with other planar mixer values. We will report on array performance in a future publication.

ACKNOWLEDGEMENT

We are extremely grateful for the constant assistance and encouragement of Dr. W.R. McGrath, without whom this work could not have been completed. We also thank Dr. H.H.S. Javadi and Dr. M.A. Frerking of JPL, and Dr. A.R. Kerr and Dr. S.K. Pan of NRAO for useful advice and discussions. We acknowledge the support of Mr. B. Bumble, Dr. J. Stern and Mr. S.R. Cypher on junction fabrication, Mr. H. Moham for fabricating the array mount, and Mr. R. McMillan for fabricating the quartz parabola. This work was carried out at the Jet Propulsion Laboratory, California Institute of Technology under contract with the National Aeronautics and Space Administration.

REFERENCES

- [1] P.L. Richards and Q. Hu, *Proceedings of the IEEE*, vol. 77, 8, pp. 1233-1245 (1989).
- [2] C.A. Mears, Q. Hu, P.L Richards, A.H. Worsham, D.E. Prober and A.V Räsänen, *IEEE Transactions on Magnetics*, vol. 27, 2, pp. 3363-3369 (1991).
- [3] W.R. McGrath, H.H.S. Javadi, S.R. Cypher, B. Bumble, B.D. Hunt and H.G. LeDuc, *Second International Symposium on Space Terahertz Technology*, Pasadena, CA, Feb. 26-28 (1991), pp. 423-428.
- [4] J.W. Kooi, M. Chan, T.G. Phillips, B. Bumble and H.G. LeDuc, *Second International Symposium on Space Terahertz Technology*, Pasadena, CA, Feb. 26-28 (1991), pp. 459-472.
- [5] A.W. Lichtenberger, D.M. Lea, A.C. Hicks, J.D. Prince, R. Densing, D. Petersen and B.S. Deaver, *Second International Symposium on Space Terahertz Technology*, Pasadena, CA, Feb. 26-28 (1991), pp. 439-458.
- [6] S.K. Pan, A.R. Kerr, M.J. Feldman, A.W. Kleinsasser, J.W. Stasiak, R.L. Sandstrom and W.J. Gallagher, *IEEE Transactions on Microwave Theory and Techniques*, vol. 37, 3, pp. 580-592, (1989).
- [7] J. Zmuidzinas and H.G. LeDuc, *Second International Symposium on Space Terahertz Technology*, Pasadena, CA, Feb. 26-28 (1991), pp. 481-490.
- [8] Q. Hu, C.A. Mears, P.L. Richards and F.L. Lloyd, *IEEE Transactions on Magnetics*, vol. 25, 2, pp. 1380-1383, (1989).
- [9] T.H. Büttgenbach, R.E. Miller, M.J. Wengler, D.M. Watson and T.G. Philips, *IEEE Transactions on Microwave Theory and Techniques*, vol. 36, 12, pp. 1720-1725 (1988).
- [10] P.H. Siegel and R.J. Dengler, *IEEE Transactions on Antennas and Propagation*, vol. 39, 1, pp. 40-47 (1991).
- [11] W.R. McGrath, A.V. Räsänen and P.L. Richards, *International Journal of Infrared and Millimeter Waves*, vol. 7, 4, pp. 543-553 (1986).
- [12] J.B. Peterson and P.L. Richards, *International Journal of Infrared and Millimeter Waves*, vol. 5, p. 1507, (1984).
- [13] J.R. Tucker and M.J. Feldman, *Rev. Modern Physics*, vol. 57, pp. 1055-1113 (1985).
- [14] J.R. Tucker, *IEEE Journal of Quantum Electronics*, vol. 15, 1234-1258 (1979).
- [15] "Handbook of Chemistry and Physics", CRC Press, 56'th ed. (1976), p. E-55.
- [16] P.H. Siegel, *First International Symposium on Space Terahertz Technology*, Ann Arbor, MI, Mar. 5-6, (1990) pp. 218-227.