

## A SUPERCONDUCTING HOT ELECTRON BOLOMETER MIXER FOR 530 GHz

A. Skalare, W. R. McGrath, B. Bumble, H. G. LeDuc  
*Jet Propulsion Laboratory, Center for Space Microelectronics Technology,  
California Institute of Technology,  
4800 Oak Grove Dr., Pasadena, CA 91109*

P. J. Burke, A. A. Verheijen, D. E. Prober  
*Dept. of Applied Physics, Yale Univ., P.O. Box 208284,  
New Haven, CT 06520-8284*

### ABSTRACT

The paper describes a superconducting hot electron bolometer mixer that uses diffusion rather than interactions with phonons as a cooling mechanism for the hot electrons. The bolometer is a 0.14  $\mu\text{m}$  wide niobium microbridge with a length less than 0.5  $\mu\text{m}$ . The submicron length ensures rapid diffusion of the hot electrons into contacting gold films. This mechanism is believed to be fast enough to allow mixer operation with intermediate frequencies of several GHz. An electron cooling time of 55 ps is inferred from DC resistance versus temperature measurements, indicating a roll-off frequency close to 3 GHz. Initial receiver measurements using a two-tuner waveguide mixer confirm heterodyne mixing at 532 GHz with an intermediate frequency of 1.4 GHz.

### INTRODUCTION

In recent years SIS devices have been used successfully for low noise astronomical receivers in the millimeter and submillimeter wave bands. There is a concern, however, that the superconducting energy gap will limit the performance of SIS mixers at frequencies above 1 THz. An alternative to SIS junctions above the gap frequency may be superconducting hot electron bolometer mixers, since the response of these should in principle be as good above the gap frequency as below. These bolometers do however have a limitation in the intermediate frequency (IF) bandwidth due to the finite time required to cool the heated electrons. This is a significant issue, since a bandwidth of at least 500-1000 MHz is required for astronomical observations. Other groups [1,2] have studied devices where the hot electrons are cooled by electron-phonon interaction, which for Nb films gives a cooling time of  $\sim 1$  ns and an IF roll-off at around 160 MHz. A receiver using a NbN bolometer, however, has recently demonstrated mixing at an intermediate frequency of 1.4 GHz [3].

We are investigating a different approach, where the hot electrons are allowed to diffuse out at the ends of the bolometer into a contacting normal metal film. If the device is very short, less than 0.5  $\mu\text{m}$ , the thermal conductance associated with the diffusion process can dominate by a factor of more than 10 over that due to the electron-phonon interaction, leading to predicted intermediate frequencies as high as 4 GHz.

One of the two objectives with the measurements presented here was to use the resistance versus temperature curve of a diffusion cooled bolometer to determine its thermal conductance, and to calculate from this value the highest usable intermediate frequency. The other objective was to adapt an existing 547 GHz SIS receiver for use with hot electron bolometers, and to attempt to make heterodyne measurements in this frequency regime.

### BOLOMETER DESIGN AND FABRICATION

The bolometer consists of a niobium microbridge 0.14  $\mu\text{m}$  wide and 10 nm thick. Different devices were fabricated with lengths ranging from 0.14  $\mu\text{m}$  to 0.5  $\mu\text{m}$ . The length was determined by varying the spacing of the gold pads that overlap the microbridge, see Fig.1. All bolometers were fabricated on 100  $\mu\text{m}$  thick fused quartz wafers, which were lapped down to 50  $\mu\text{m}$  after the device formation.

The first step in the device fabrication is the definition of the base wiring layer, which was patterned onto the quartz substrate using an optical lift-off process. The layer consists of 110 nm of magnetron sputtered Nb and 30 nm of evaporated Au. The device layer is then fabricated by a blanket deposition of 10 nm of Nb followed by 10 nm of Au. An etching mask of 30 nm of Cr is patterned using e-beam lithography with PMMA, which defines the bolometer. The microbridge is produced by Ar sputtering of the gold, followed by reactive ion etching of the Nb with a mixture of  $\text{CCl}_2\text{F}_2 + \text{CF}_4 + \text{O}_2$ . The chromium etch mask was subsequently stripped by a commercially available wet etch. The 100 nm thick gold leads were evaporation deposited using an e-beam defined PMMA lift-off mask. The 10 nm thick gold layer on top of the Nb bolometer was then removed by an Ar sputtering step. The finished devices were passivated by deposition of 40 nm of SiO in a lift-off process.

### CALCULATED THERMAL RESPONSE TIME

The voltage responsivity of the bolometer can be written [4] :

$$S = I \cdot \frac{dR}{dT} \cdot \frac{1}{G \cdot (1 + \omega_{IF}^2 \tau^2)^{1/2}} \quad (\text{V/W}) \quad (\text{Eq. 1})$$

where I is the DC bias current, R is the microbridge resistance, T is the temperature, G is the thermal conductance between the hot electrons and the thermal bath,  $\omega_{IF}$  is  $2\pi \times$  the intermediate frequency, and  $\tau$  is the thermal response time (cooling time) of the hot electrons. The response time is  $\tau = C / G$ , where C is the electronic specific heat of the bolometer.

From Eq.1 it is clear that the response rolls off at the frequency :

$$f_0 = \frac{1}{2\pi\tau} \quad (\text{Hz}) \quad (\text{Eq. 2})$$

The electronic specific heat of the bridge is given by:

$$C = \gamma \cdot T \cdot V \quad (\text{J/K}) \quad (\text{Eq. 3})$$

where V is the volume of the niobium microbridge and  $\gamma \approx 700 \text{ J/K}^2\text{m}^3$  (experimental bulk value).

The Wiedemann-Franz law gives the ratio of the electronic thermal conductivity to the electrical conductivity. This predicts :

$$G_{WF} = \frac{\pi^2}{3} \left( \frac{k_B}{q_e} \right)^2 \cdot \frac{T}{R_{Eff}} \approx 2.44 \cdot 10^{-8} \cdot \frac{T}{R_{Eff}} \quad (\text{W/K}) \quad (\text{Eq. 4})$$

In our case  $R_{Eff}=R/12$  . This is an effective resistance that corrects for the distributed heat dissipation and for the two heat sinks at opposite ends of the microbridge [4]. The resulting value of the thermal response time is given below, and should be used in Eq. 1 if it is much smaller than the electron-phonon time.

$$\tau_{WF} = C / G_{WF} \quad (\text{s}) \quad (\text{Eq. 5})$$

### MEASURED THERMAL RESPONSE TIME

The thermal conductivity G can be estimated from measuring the resistance versus substrate temperature characteristic for a bolometer at different DC bias currents. Figure 2 shows such a measurement for a 0.2 μm long microbridge. The power dissipated in the device by the DC current heats the electrons above the substrate temperature, thereby shifting the R-T curve. The shift in temperature for any given R is equal to the difference in dissipated power ( $I_1^2 \cdot R - I_2^2 \cdot R$ ) divided by G. The difference in dissipated power versus the shift in temperature for three pairs of currents ( $I_1, I_2$ ) and several values of R is plotted in Fig.3 . The slope of the fitted curve is the experimental value of G.

Table 1 compares the experimental value  $G_{Exp}$  to the Wiedemann-Franz limiting case  $G_{WF}$  for two bolometers of different lengths. It also lists the heat conductivity of the electron-phonon interaction  $G_{el-ph} = 4 \cdot A \cdot T^3 V$ , where  $A \approx 1.1 \cdot 10^{10} \text{ W/K}^4 \text{m}^3$  [5]. As shown in the table, the experimental heat conduction is significantly better than that of the electron-phonon interaction, but it is less than that predicted by the Wiedemann-Franz law. The experimental values of the heat conduction together with the specific heat according to Eq. 3 above give estimated IF roll-off frequencies of close to 3 GHz for both bolometers.

Table 1 : Comparison of calculated and experimental values of thermal conductance, time constant and IF roll-off frequency. Two expressions used in creating the table are  $\tau_{Exp} = C / G_{Exp}$  and  $IF_{Max}=1 / (2\pi \cdot \tau_{Exp})$ . The device temperature is taken to be 5.2 K, and the width is 0.14 μm.

Length [μm]	Resistance [Ω]	C [J/K]	$G_{el-ph}$ [nW/K]	$G_{WF}$ [nW/K]	$G_{Exp}$ [nW/K]	$\tau_{Exp}$ [ps]	$IF_{Max}$ [GHz]
0.14	12.1	$7.1 \cdot 10^{-19}$	1.2	127	12.5	57	2.8
0.2	18.3	$10.2 \cdot 10^{-19}$	1.7	83	18.5	55	2.9

## MIXER MEASUREMENTS

Mixer measurements were carried out using a waveguide SIS receiver for 547 GHz [6]. The quartz chips with the bolometers were glued into a two-tuner mixer block, as shown in Fig. 4. The contacting sliding tuners were made from beryllium copper, and the DC and IF connections were made by wire bonding the device to the mixer block and to a matching circuit. The mixer block was mounted onto the 4 Kelvin cold surface of a vacuum cryostat, as shown in Fig. 5. A 1 k $\Omega$  metal film resistor in thermal contact with the mixer block was used as a heater to vary the temperature of the bolometer. The temperature of the block was monitored by a diode sensor. Because of temperature gradients in the mixer block, however, we found that the thermal noise power in the intermediate frequency band provided a more accurate way of measuring the device temperature. No feed-back loop was needed for the temperature control, as the diode sensor temperature versus heater voltage was reproducible to within 20 mK over a period of several hours. As shown in Fig.5 the beam from the signal source is focussed into the dual-mode conical feedhorn of the mixer block using off-axis elliptical mirrors. Two fluorogold infrared filters are placed in the beam path inside the cryostat, to reduce room temperature heat flux into the mixer.

The signal source was a  $\times 2 \times 3$  multiplier that was pumped by two Gunn oscillators as shown in Fig.5. Gunn 1 in the figure was used to pump the multiplier at the frequency  $f_{\text{Gunn 1}}$ , thereby providing the local oscillator (LO) for the hot electron bolometer at  $6 \times f_{\text{Gunn 1}}$ . The second Gunn was used to inject a small amount of power at frequency  $f_{\text{Gunn 2}}$  into the multiplier through a -20 dB coupler. This resulted in additional output power from the multiplier at a frequency  $5 \times f_{\text{Gunn 1}} + f_{\text{Gunn 2}}$ , thus providing a monochromatic signal. The reason that we used this source configuration was that only one multiplier was available for the experiments. The frequencies of the two Gunn oscillators could be independently measured with a frequency counter (Fig.5).

The 1.4 GHz intermediate frequency (IF) system is shown in Fig.6. The cooled amplifier had a nominal noise temperature of 5.6 K, but due to the other components in the system the total IF noise temperature was between 6.5 and 7.0 K, depending on the IF impedance of the device in the mixer block. Several configurations of the room temperature part of the IF system were used, giving total gain values from the mixer to the power meter ranging from 90 to 105 dB. Part of the IF output power was coupled to a spectrum analyzer, to verify the heterodyne response with the monochromatic signal source.

The bolometer used in the mixing experiments had a length of 0.2  $\mu\text{m}$ , and a width of 0.14  $\mu\text{m}$ . The normal resistance was 23.5  $\Omega$ . Fig. 7 shows two I-V curves. The first was measured on a dip-stick with the device immersed in liquid helium. The second was measured in the receiver cryostat, where the device was slightly warmer.

The receiver measurements were made at a local oscillator frequency of 532 GHz with the signal in the upper sideband. The temperature at the sensor on the outside of the mixer block was 4.6 K, but the actual temperature of the bolometer was a few tenths of a Kelvin lower. Figure 8 shows the IF spectrum for five different frequency settings of the signal Gunn oscillator. Shifting the monochromatic signal frequency causes a corresponding shift in the IF spectrum, which shows that the response is heterodyne. We also verified that the measured frequency of the IF signal equals the difference between the measured frequencies of the two Gunn oscillators. The mixer output shows a maximum at

a bias voltage of about 0.1 mV, as shown in Fig.9 . The figure shows the total output power in the intermediate frequency band with and without a signal. It also shows one pumped (with local oscillator power at 532 GHz) and one unpumped (no local oscillator power) I-V curve. In this measurement the total gain in the amplifier chain was ~94 dB, not including the mismatch between the device and the 105  $\Omega$  IF system.

When the mixer block was heated, the mixer output signal decreased. The data in Fig.10 was prepared by subtracting the output powers with and without signal at a few different temperatures. The local oscillator and signal power levels were held constant for the data points in the figure. As can be seen, the mixer output fell rapidly as the bolometer approached the critical temperature of the niobium film, which was 5 to 5.5 K. The temperatures in Fig.10 were inferred from measurements of the thermal noise in the intermediate frequency band from the device at zero bias current. Due to small uncertainties in the calibration of the intermediate frequency amplifier chain, we estimate the systematic error in the temperature readings to be approximately 0.4 K .

When the device is in the limit of small heating of the electrons above the bath temperature by the DC current, the temperature in the Wiedemann-Franz law may be approximated by the bath temperature  $T_b$ . This leads to a temperature increase for the hot electrons that is proportional to the DC power  $P_0$ , so that  $(T_h - T_b) \propto P_0 = R \cdot I_0^2$  where  $T_h$  is the hot electron temperature. The hot electron temperature increase should be proportional to  $I_0^2$ . For large DC bias currents this approximation is incorrect, and instead the Wiedemann-Franz law leads to the dependence  $(T_h^2 - T_b^2) \propto P_0 = R \cdot I_0^2$ . This means that for large bias currents the hot electron temperature should increase in proportion to  $I_0$ . This would cause the output thermal noise power from the device to increase in proportion to  $I_0$  instead of  $I_0^2$ . This linear dependence can be observed in Fig. 11 . It should be pointed out, that a linear dependence of output noise power with current can also be indicative of shot noise. This requires, however, that a tunneling barrier is present in the device. At this point we are not aware of any such barrier.

## SUMMARY

The resistance versus temperature measurements of the 0.2  $\mu\text{m}$  long electron diffusion cooled bolometer indicates that the thermal conductivity is approximately 18.5 nW/K. Together with an estimated electronic specific heat of  $10.2 \cdot 10^{-19}$  J/K this gives a thermal response time of 55 ps, leading to an estimated highest intermediate frequency of 2.9 GHz. This would clearly be sufficient for heterodyne receivers for submillimeter astronomy. The shorter (0.14  $\mu\text{m}$ ) bolometer gave similar results, namely 57 ps and 2.8 GHz.

A quartz chip with a 0.2  $\mu\text{m}$  long bolometer was mounted into an existing waveguide block SIS receiver. Measurements using a local oscillator and monochromatic source confirm that the bolometer shows heterodyne response at a local oscillator frequency of 532 GHz and an intermediate frequency of 1.4 GHz. The strongest mixing is seen at bias currents slightly above the non-linearity in the I-V curve. The IF signal output power decreases strongly with temperature, which suggests that the heterodyne response will be even stronger with the device cooled to lower temperatures than in our present measurements.

At high DC bias currents the output noise in the intermediate frequency band increases proportionally with the current, which is predicted by the Wiedemann-Franz law in the large heating limit. A proportional dependence of output power on bias current can also be expected from a shot noise source, but no such source in the device is known to us at this time.

#### ACKNOWLEDGEMENTS

We express our gratitude to Paul D. Maker and Richard E. Muller for their assistance in setting up the PMMA / Electron beam lithography.

This research was performed by the Jet Propulsion Laboratory, Center for Space Microelectronics Technology, California Institute of Technology and by Yale University and was jointly sponsored by the NASA Office of Advanced Concepts and Technology, the BMDO Innovative Science and Technology Office, and the National Science Foundation. Funding for P. J. Burke was provided by a NASA Graduate Student Fellowship as well as a Connecticut High Technology Fellowship.

#### REFERENCES

- [1] E. M. Gershenson, G. N. Gol'tsman, I. G. Gogidze, Y. P. Gusev, A. I. Elant'ev, B. S. Karasik, A. D. Semenov, "Millimeter and Submillimeter Range Mixer Based on Electronic Heating of Superconducting Films in the Resistive State", *Superconductivity* 3 (10), pp.1582-1597 October 1990.
- [2] H. Ekström et al., These proceedings
- [3] O. Okunev et al., These proceedings
- [4] D. E. Prober, "Superconducting Terahertz Mixer using a Transition-Edge Microbolometer", *Appl. Phys. Lett.* 62(17), 26 April 1993
- [5] E. M. Gershenson et al., *Superconductivity* 5 (6), pp. 1129, 1992
- [6] P. Febvre, W. R. McGrath, P. Batelaan, B. Bumble, H. G. LeDuc, S. George, P. Feautrier, "A Low-Noise SIS Receiver Measured from 480 GHz to 650 GHz using Nb Junctions with Integrated RF Tuning Circuits", To appear in *Int. J. Infrared & Millimeter Waves*, Vol. 15, No. 6, June 1994.

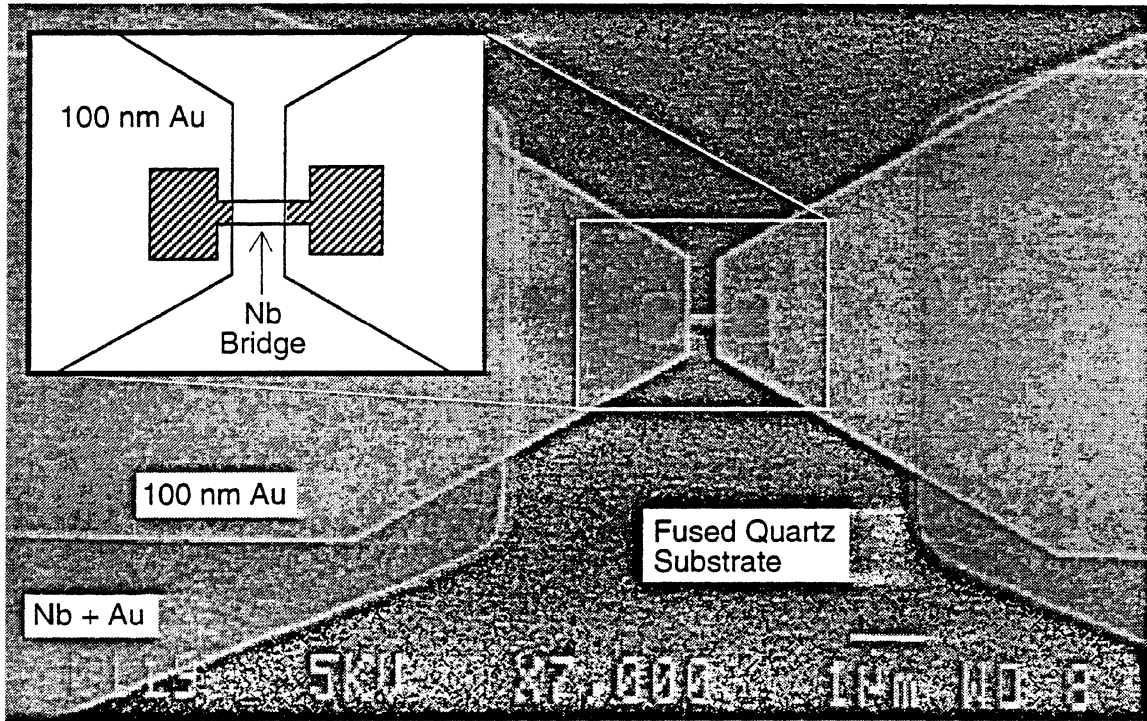

Fig. 1: SEM image of a hot electron bolometer. The crosshatched areas in the inset are 10 nm of Au on 10 nm of Nb; both layers are under the large 100 nm Au film.

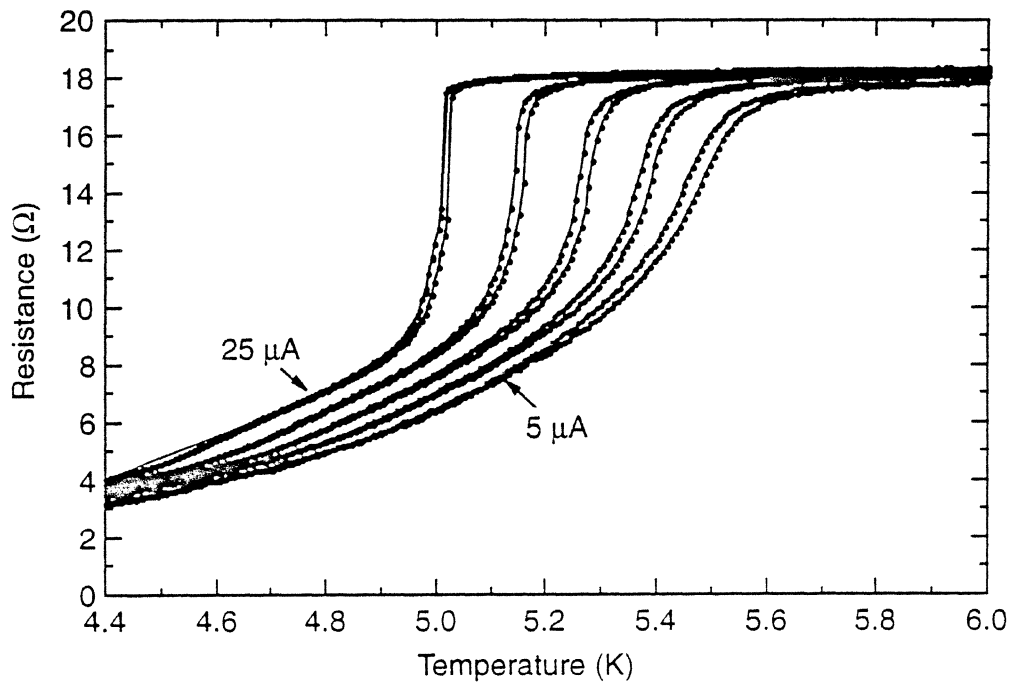

Fig. 2: R versus T for a 0.2  $\mu$ m long bolometer. The different curves were measured at 5, 10, 15, 20 and 25  $\mu$ A.

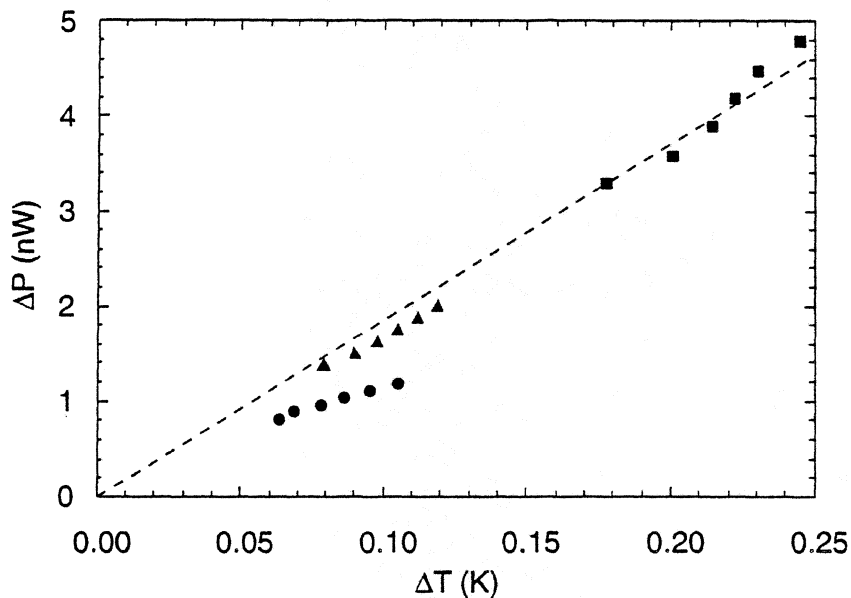

Fig.3: The difference in dissipated DC power  $\Delta P$  plotted against the temperature shift  $\Delta T$ , for three different pairs of R-T curves. Six points are plotted for each pair, corresponding to different resistance values. Ideally, all the points would fall on a straight line through the origin, the slope of which would be the thermal conductivity  $G$ . The dashed line in the figure gives  $G_{Exp} = 18.5$  nW/K. The data is for an  $0.2 \mu\text{m}$  long device. The three DC current pairs are:  $I_1=5\text{mA}$  &  $I_2=10\text{mA}$  (●);  $I_1=10\text{mA}$  &  $I_2=15\text{mA}$  (▲);  $I_1=10\text{mA}$ ,  $I_2=20\text{mA}$  (■).

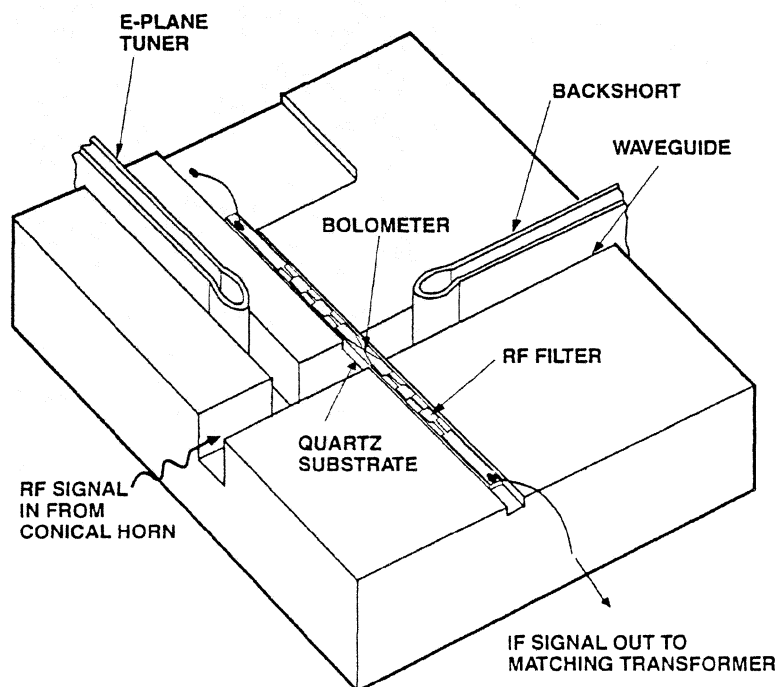

Fig. 4: Split view of the waveguide block showing the bolometer substrate.



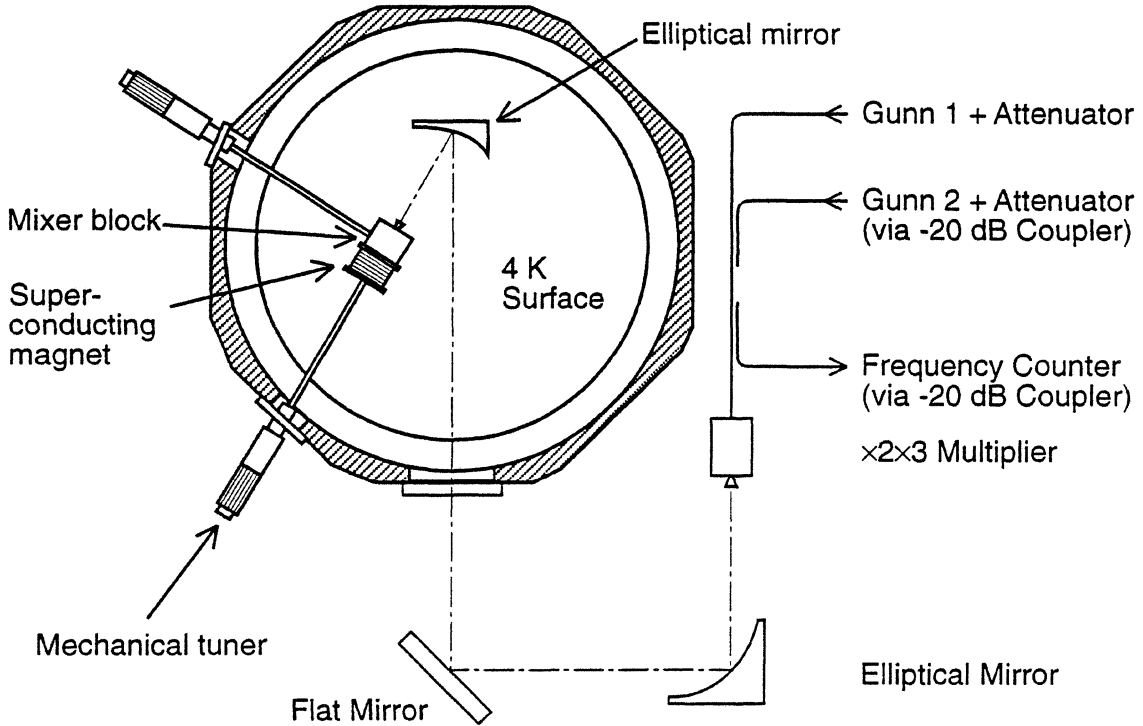

Fig. 5: Schematic view of the vacuum cryostat, the beam path and the multiplier source.

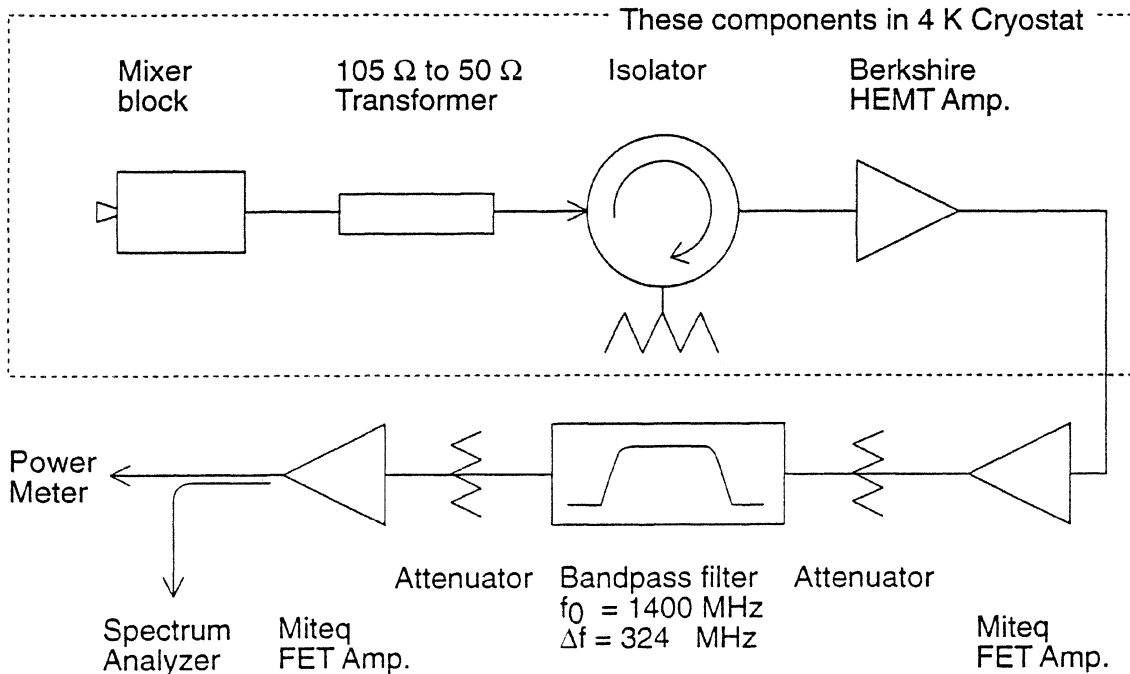

Fig. 6: The intermediate frequency (IF) chain.

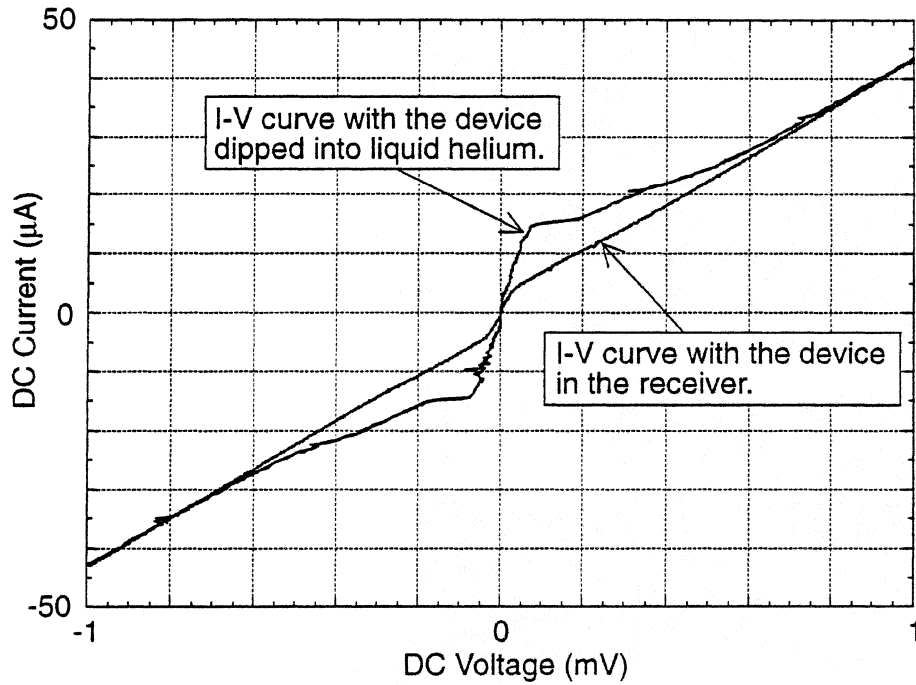

Fig. 7: Two DC I-V curves of the 0.2  $\mu\text{m}$  device used in the mixer measurements. The difference between the I-V curves is due to the slightly warmer environment in the receiver.

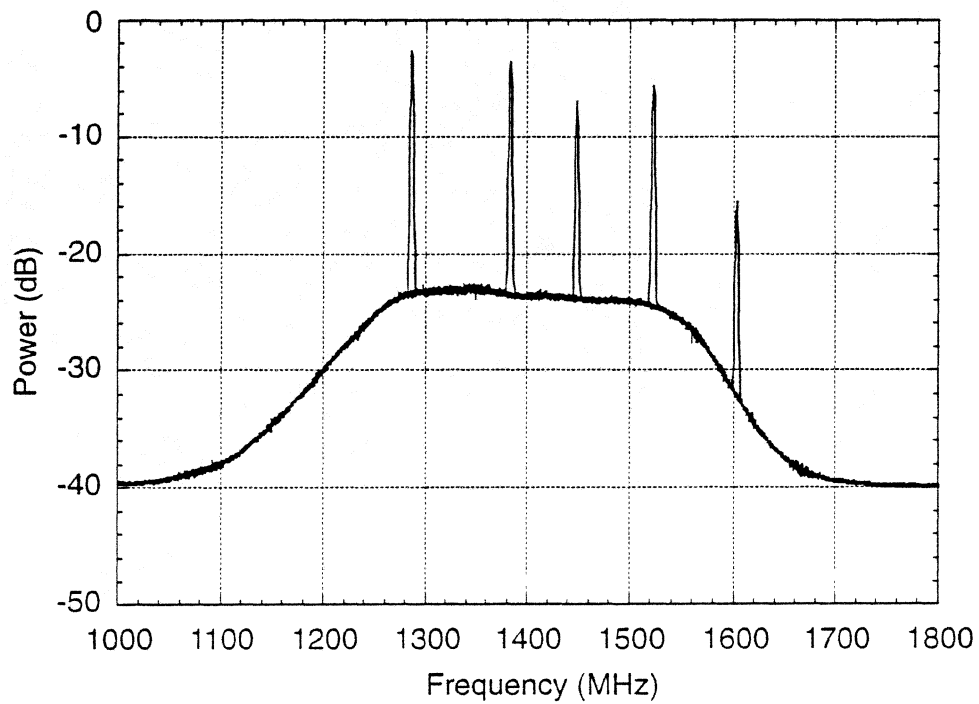

Fig. 8: The intermediate frequency spectrum for 5 different signal frequencies.

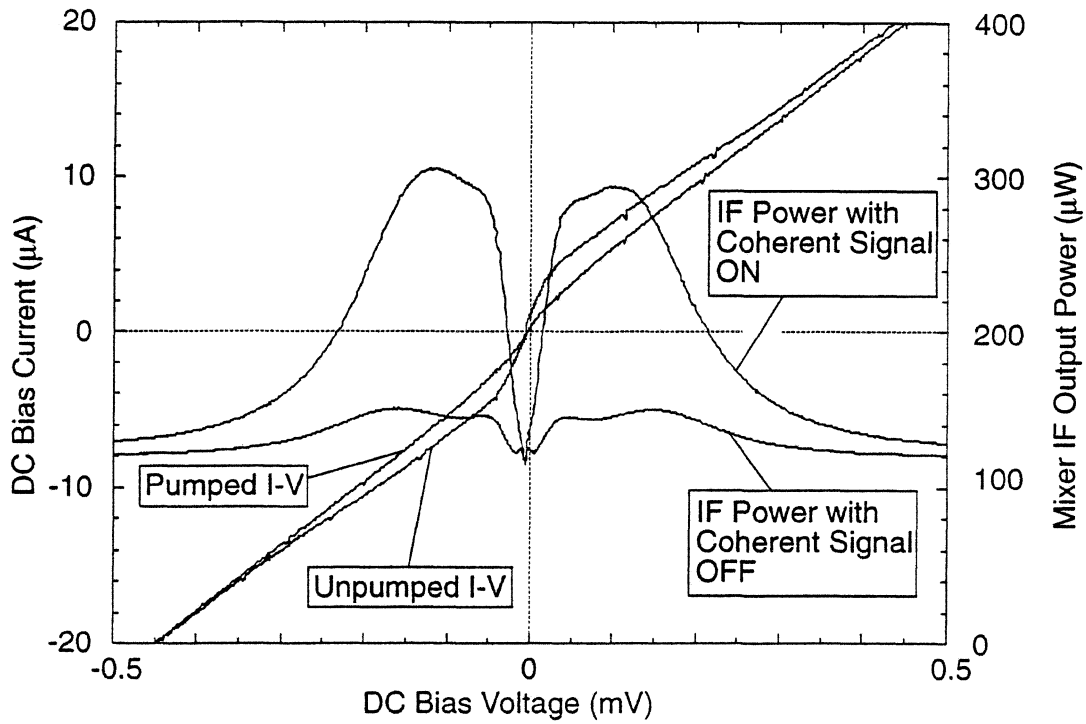

Fig. 9: Total output power in the intermediate frequency band as a function of DC bias voltage. The IF output power in this graph includes amplifier noise.

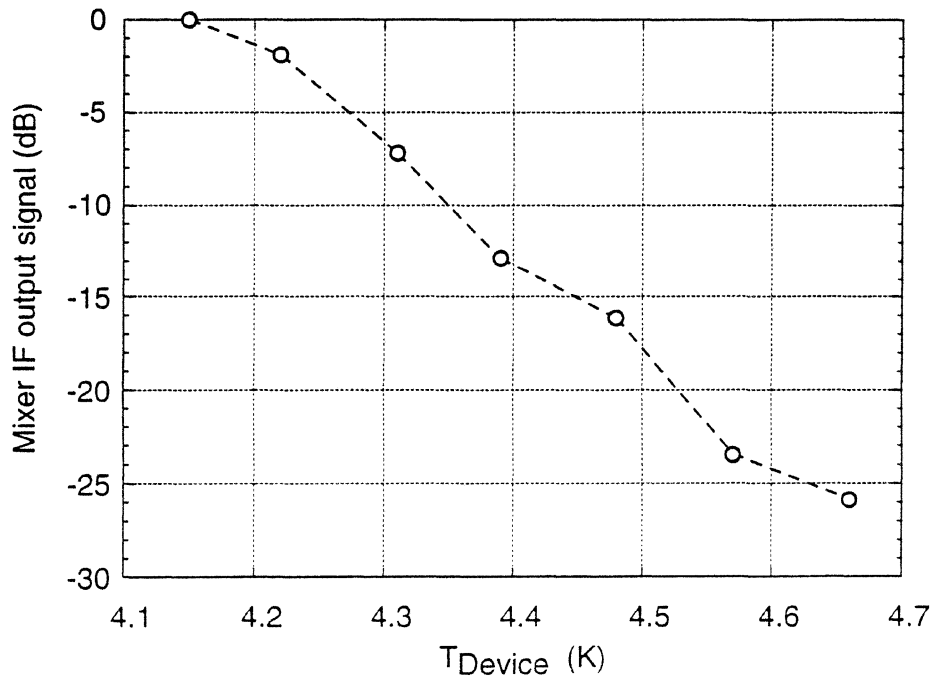

Fig. 10: The mixer output signal as a function of temperature.

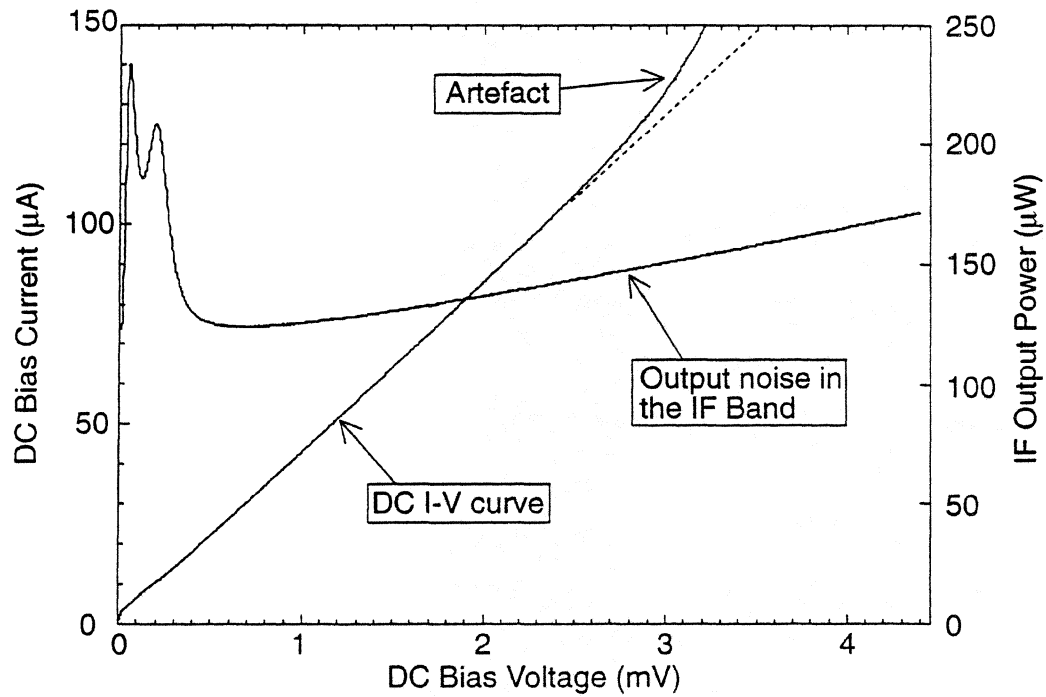

Fig. 11: The I-V curve and output power in the intermediate frequency band. On this scale, the non-linear part of the I-V curve is barely visible at the lower left corner of the diagram. The bend upwards at high bias currents is an artefact caused by a current limiting diode in the bias circuit. The output noise power curve includes approximately  $90 \mu\text{W}$  of amplifier noise.