

Performance of Micromechanical Tuning Elements in a 620 GHz Monolithic Integrated Circuit

Victor M. Lubecke,^{1†} William R. McGrath,² Philip A. Stimson,^{2‡} and David B. Rutledge¹

¹ Department of Electrical Engineering,
California Institute of Technology, Pasadena, CA 91125, USA

² Jet Propulsion Laboratory,
California Institute of Technology, Pasadena, CA 91109, USA

Abstract

The submillimeter wave performance of micromechanical tuning elements called *sliding planar backshorts* (SPB's) is demonstrated in a quasi-optical monolithic integrated circuit. A substrate-lens is used to focus incident radiation onto a circuit consisting of a full-wave resonant slot antenna and a thin-film bismuth detector, joined by coplanar waveguide (CPW) transmission lines with integrated SPB's. The CPW lines act as tuning stubs with electrical lengths which can be varied by mechanically adjusting the position of the SPB's. Two SPB's are used, one to create a variable series reactance in between the antenna and detector, and the other to create a variable susceptance in parallel with the detector. Microwave measurements for a scale model of the SPB show it to have a return loss of as little as 0.02 dB, and less than 0.5 dB over a 30% bandwidth. Measurements at 620 GHz indicate that the micromechanical SPB's perform consistently with the model, and the two tuning elements are used to vary the response of the detector over a range of nearly 15 dB. The impedance matching capability provided by the SPB's allow a circuit of this type to accommodate a wide range of planar submillimeter wave antennas and devices without advance knowledge of their exact electrical characteristics. Such tuning elements can be useful for characterizing components in developmental circuits, and for optimizing the in-use performance of various submillimeter wave integrated circuits.

† V.M. Lubecke is presently with the Jet Propulsion Laboratory, California Institute of Technology, Pasadena, CA 91109, USA

‡ P.A. Stimson is presently with the Defence Science and Technology Organisation, Salisbury, SA 5108, Australia

I. Introduction

Over the past two decades, mechanically-tunable waveguide circuits have been used to make sensitive measurements in the millimeter and submillimeter wave bands. In these circuits devices such as Schottky diodes or superconductor-insulator-superconductor (SIS) junctions are embedded in waveguide mixer blocks, and waveguide tuning stubs with mechanically adjustable backshorts are used to compensate for device parasitics and optimize performance. Though waveguide technology is well developed for the lower portion of this frequency range, fabrication remains a difficult and costly procedure. At the higher frequencies of the submillimeter band, the dimensions of these waveguide structures become exceedingly small, and painstaking efforts and innovative fabrication techniques must be employed to realize them. Thus, there is a growing interest in alternative technologies which are better suited for the fabrication of intricate circuits for use at these high frequencies, and which can offer improved mechanical integrity for air and space borne applications.

An attractive option is the use of planar integrated circuit technology. The planar structure of the SIS junction and modern planar Schottky diodes make them ideally suited for integration with planar antennas and impedance matching networks to form fully monolithic integrated mixer circuits. These circuits can be fabricated through photolithographic techniques alone, making them far more simple to fabricate for increasingly higher frequencies than three-dimensional waveguide circuits. This approach provides better reproducibility and reliability, allows for the creation of focal plane imaging arrays without an increase in the complexity of the fabrication process, and could potentially allow for the inclusion of IF circuitry to form fully integrated receivers.

Various monolithic circuits of this type have already been demonstrated utilizing SIS junctions and planar Schottky diodes as mixing elements [1-3]. These circuits employ a substrate lens to quasi-optically couple to millimeter and submillimeter wavelength radiation, entirely avoiding the use of waveguide components. These circuits, however, are not without drawbacks. Device parasitics must be compensated for using planar

circuit elements which are typically of fixed form, and thus do not provide a means of post-fabrication optimization. This results in a greater need for accurate device and circuit characterization, and optimization through iterative fabrication.

It would be desirable to integrate into these planar circuits adjustable tuning elements which would function analogously to the adjustable backshorts found in waveguide circuits. Their interaction with a device could be studied in developmental circuits as an aid to characterizing the device. Ultimately, they could provide an integrated submillimeter wavelength receiver with a means for the same type of real-time performance optimization which is available in waveguide circuits. For this reason we've developed a mechanically adjustable planar tuning element called a *sliding planar backshort* (SPB), which serves to adjust the electrical length of the planar transmission line into which it is integrated[4]. The tuning element is fabricated with a unique implementation of photolithographic micromachining techniques, and preserves all of the benefits typically associated with planar integrated circuits. The submillimeter wave performance of two such micromechanical tuning elements is demonstrated here in a fully monolithic integrated circuit.

II. Design

A quasi-optical 620 GHz monolithic direct-detection circuit was developed to demonstrate the operation of integrated SPB's. This circuit uses a dielectric-filled parabola[5] to focus radiation onto a slot antenna, and couples this radiation to a bismuth detector by means of two coplanar waveguide (CPW) transmission lines, each with integrated SPB's. One SPB creates a variable series reactance between the antenna and the detector, potentially serving to compensate for any off-resonance reactance of the slot. The other SPB creates a variable susceptance in parallel with the detector, and acts to compensate for the parasitic capacitance found in otherwise desirable submillimeter wave devices. The integrated circuit design is illustrated in Fig. 1.

An SPB consists of a rectangular metal plate, with appropriately sized and spaced holes, which rests on top of a dielectric-coated planar transmission line. The impedance of

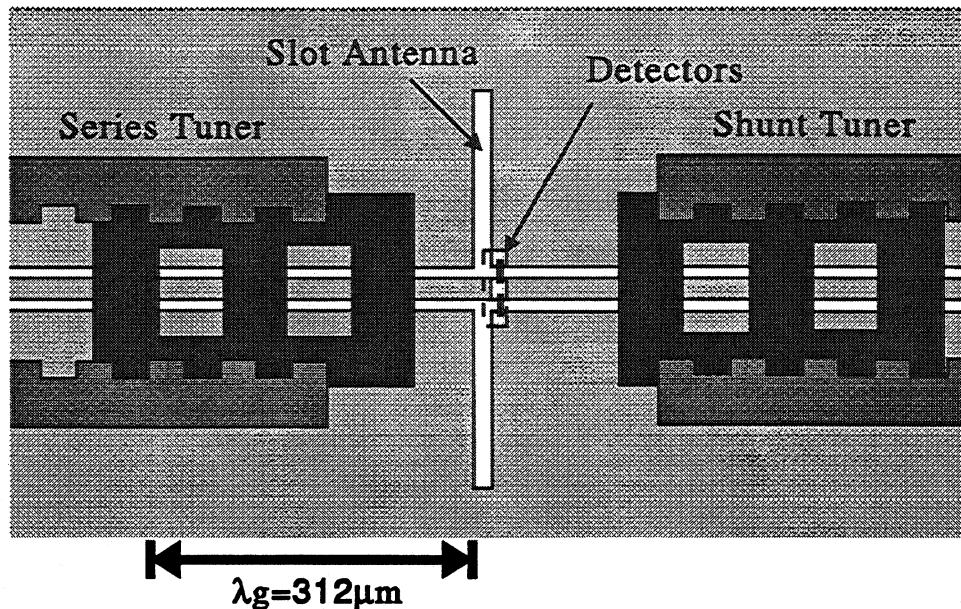

Figure 1. The 620 GHz detector circuit. Two micromechanical SPB's on dielectric coated CPW transmission lines form the adjustable impedance matching circuit.

the sections of line covered by metal is greatly reduced, while the uncovered sections retain their higher impedance. Each of these sections is approximately one quarter-wavelength long, and the cascade of alternating low-impedance and high-impedance sections results in an extremely low-impedance termination at the position along the transmission line at which the plate is positioned.

The critical dimensions of the 620 GHz SPB's used in this experiment were scaled from a tuning element which was empirically designed at 2 GHz for use on a 204Ω coplanar strip transmission line[4]. The 78Ω CPW used here is the physical dual of that transmission line, and the return loss of the SPB in this application was also measured at 2 GHz, as $|s_{11}| = -0.06$ dB. This measurement was made using an HP 8510 and $|s_{11}|$ remains below -0.5 dB over a 30% bandwidth, as shown in Fig. 2. The frequency scaled SPB consisted of three covered sections, each approximately $80 \mu\text{m}$ long, and two uncovered sections, approximately $65 \mu\text{m}$ and $75 \mu\text{m}$ long. Additional uncovered and covered sections were added to the trailing end of the SPB, to better facilitate its manipulation with a mechanical probe. The width of the exterior of the 620 GHz SPB was $200 \mu\text{m}$, and

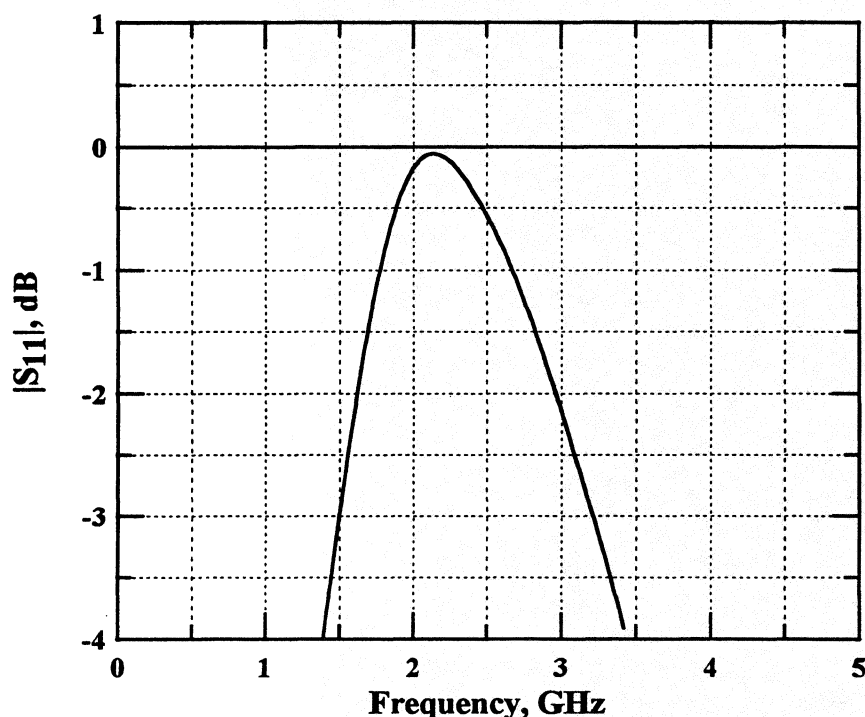

Figure 2. Plot of measured 2 GHz reflection coefficient for an SPB on $78\ \Omega$ CPW line. The dimensions of this tuning element were scaled to create the 620 GHz micromechanical SPB.

the holes were $110\ \mu\text{m}$ wide. These dimensions were chosen to avoid lateral resonances at the design frequency.

The dielectric-filled parabola used in this experiment consisted of a plano-convex fused-quartz lens, with the convex surface shaped into a parabola with an f/D ratio of 0.25. The parabolic side was metallized to function analogously to a conventional parabolic dish antenna, focusing incident paraxial radiation to a small beam-waist. The integrated detector circuit was fabricated on a fused-quartz wafer and positioned on the lens so that the antenna coincided with this beam-waist.

The CPW transmission lines were designed to optimize the effect of the tuning elements, and the antenna was designed to be compatible with the dimensions of the CPW and SPB's. The antenna was a full-wave resonant slot, $261\ \mu\text{m}$ -long, $5\ \mu\text{m}$ -wide, designed to have a feed impedance of $24\ \Omega$ at 620 GHz[6]. The CPW transmission lines

consisted of a $16\ \mu\text{m}$ -wide center conductor, with $8\ \mu\text{m}$ -wide gaps on each side, and was designed to have a characteristic impedance of $78\ \Omega$ [7]. The line was also designed to minimize loss due to radiation into the substrate. Conductor loss for such a line can be minimized by the use of a highly conductive metal or superconducting film. Total loss for the lines in this experiment was calculated to be $0.6\ \text{dB}/\lambda_g$ [7],[8].

For this experiment a small bismuth film was used to create a self-heating thermocouple for detection of the submillimeter radiation. It was patterned across the CPW near the antenna. Current induced in the antenna by a submillimeter signal passes through the film and heats it, and the physical asymmetry of the interface between the bismuth and the conductors of the CPW results in a thermal-electric voltage which is proportional to the power absorbed by the film. This circuit was designed to accommodate a four-wire resistance measurement, allowing the bismuth film to be used as a microbolometer as well[9]. The advantage of using the film as a thermocouple is that it requires no bias current, and thus has no $1/f$ noise[10]. Using a bismuth film which is much thicker than the metal layer contacts which the detector must overlap, insures good edge coverage and also results in a low-impedance detector which closely matches the $24\ \Omega$ antenna. The measured DC resistance of the two bismuth detectors ($33\ \Omega$ and $42\ \Omega$) appeared in parallel for the RF circuit as $18.5\ \Omega$. This impedance match, and consequently the output of the circuit, could then be altered by varying the positions of the SPB's.

III. Fabrication and Measurements

The antenna, CPW, and detectors were fabricated using fairly standard photolithographic techniques. The SPB's were fabricated using a unique application of molding and sacrificial-layer techniques which are commonly applied in the micromachining of silicon, to materials and processes suitable for a submillimeter wave integrated circuit[11],[12].

The entire circuit was fabricated on a circular, 18 mm-diameter, $254\ \mu\text{m}$ -thick fused-quartz wafer. A $1000\ \text{\AA}$ layer of evaporated gold was used for the etched antenna and CPW. A $1000\ \text{\AA}$ layer of silicon-dioxide was then sputtered on over a photoresist lift-off stencil to form the dielectric layer. The SPB's were then formed by first applying

a 1700 Å sacrificial-seed layer of copper followed by a 5 μm-thick layer of electroplated gold, patterned with a photoresist mold. A 1 μm layer of copper was then electroplated onto this structure, followed by a spun-on layer of polyimide, patterned to form the guide structures. The sacrificial copper was then etched away, releasing the gold electroplated SPB's to slide freely within the polyimide guide structures. Finally, a 6000 Å bismuth film was evaporated over a photoresist stencil to form the detectors. The circuit is shown in Fig. 3.

The circuit was mounted in a brass fixture, over a recess containing the fused-quartz parabola with gold-film backing. Aluminum bond wires were used to connect the center and outer conductors on each end of the CPW, to individual printed circuit boards on the mount, each terminated with an SSMA connector. This was done in order to allow various connection methods to be tried for measurement of the detected signal. The fixture was attached, with the circuit facing upwards, to an adjustable gimbal-mount on top of two orthogonal linear-translation stages mounted on an optical-measurement

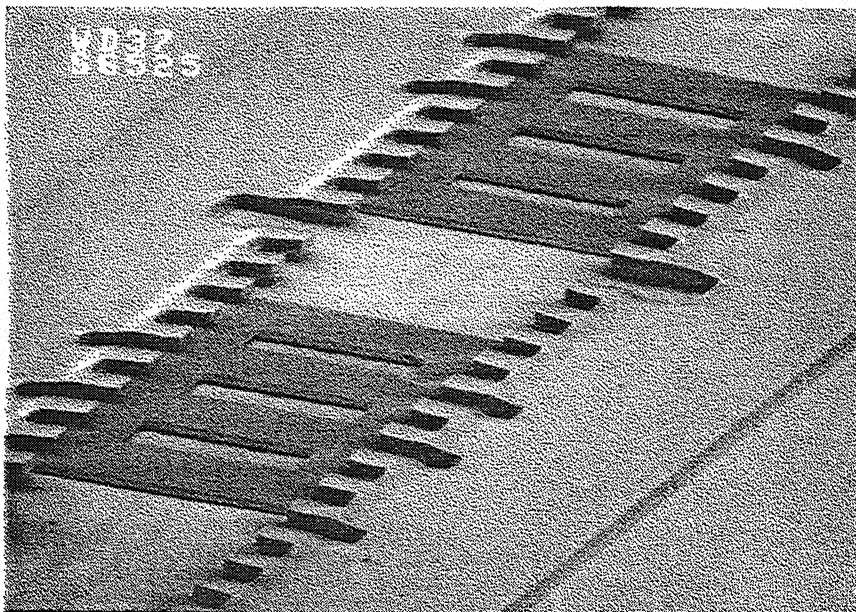

Figure 3. An SEM of the micromechanical integrated circuit. Two 5 μm-thick, 200 μm-wide micromechanical SPB's slide along CPW transmission lines to tune the circuit

table. A gold mirror mounted on translational and rotational stages was used to direct a horizontally incident signal onto the circuit. A microscope with a magnification of $1000\times$ was positioned at an angle above the circuit, to aid in the manipulation of the SPB's. The set-up is illustrated in Fig. 4.

A Backward Wave Oscillator (BWO) was used as a 620 GHz source. This source provided only a couple of milliwatts of multimoded power, with much less than 1 mW present in the fundamental mode which couples to the circuit. It was positioned behind a 25 Hz chopper and as close as possible to the gold mirror. A PAR 125A lock-in amplifier was used to measure the output voltage of the detector. The system was first aligned to maximize the detected signal (approximately $2\ \mu\text{V}$) with the tuning elements in somewhat arbitrary positions. The voltage was measured across the two detectors in series.

A probe was fashioned with a $50\ \mu\text{m}$ -diameter ox hair at its tip, and this was used to manually position the SPB for each measurement. It would be desirable to implement probes on micrometer driven positioners to move the SPB's. This was planned, but proved difficult to implement in the actual circuit tested. The small amount of power available at 620 GHz necessitated placement of the circuit very close to the tube output (an overmoded waveguide horn) in order to minimize losses. This left no room for the

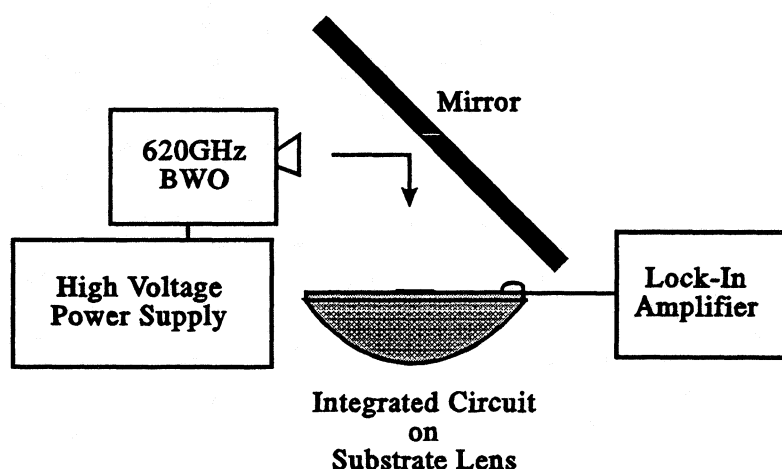

Figure 4. Diagram of the quasi-optical measurement set-up for the 620 GHz integrated circuit. A mirror was used to direct a test signal to the dielectric-filled parabola.

positioners.

The measured data obtained by sweeping the position of the series tuning element incrementally over a distance of one guide-wavelength, for one position of the parallel tuning element, is shown in Fig. 5. Data sets obtained by sweeping the parallel tuning element incrementally over a range of three guide-wavelengths for two different positions of the series tuning element are shown in Fig. 6. These results were recorded over several experimental runs spaced some hours apart, and different symbols have been plotted to represent groups of data recorded in each run. Data for each sweep were normalized to a reference measurement taken with the SPB which created the parallel susceptance positioned near $\lambda_g/4$, and the SPB which created the series reactance positioned near $\lambda_g/2$. The series tuning element was not swept over the full three guide-wavelengths because of a mechanical flaw in its fabrication. In each measurement sweep, the SPB's functioned to vary the power through multiple peaks and nulls in a repeatable manner.

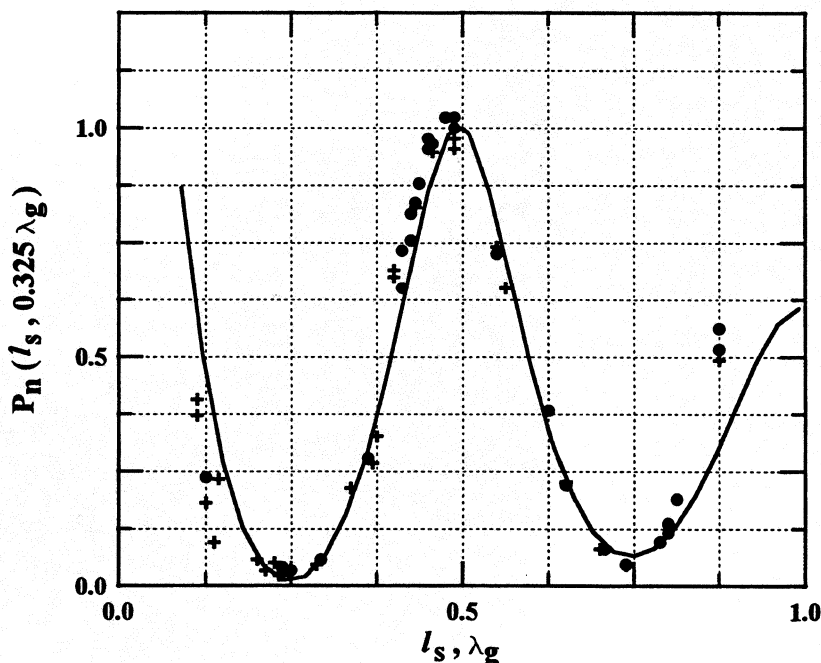
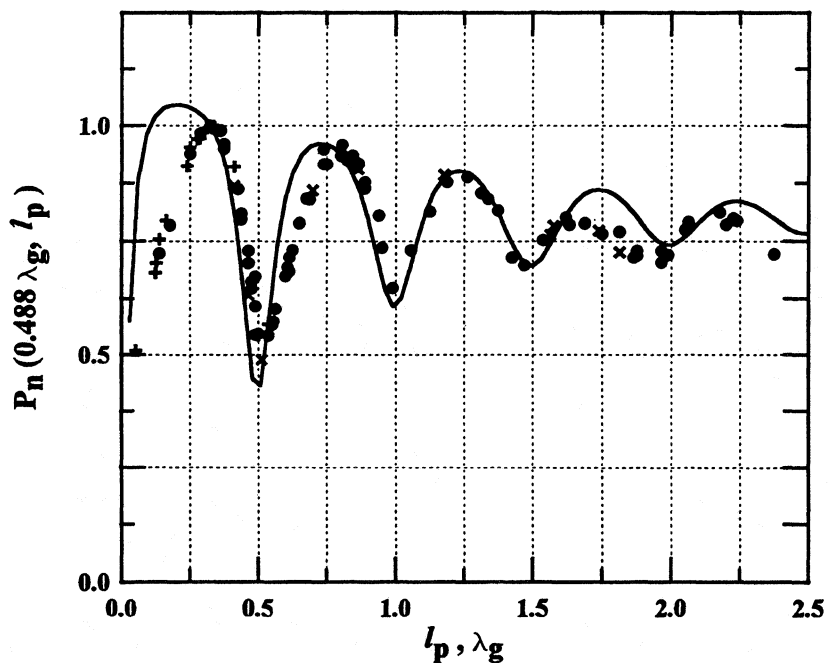
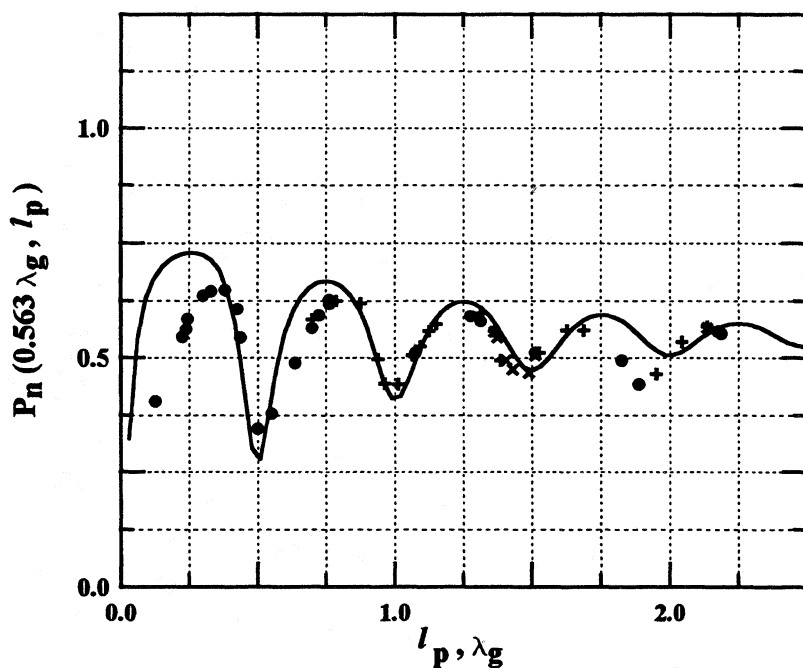

Figure 5. Measured (\bullet)($+$) and theoretical (—) response for 620 GHz detector circuit. The power absorbed by the detector is shown as a function of the series tuner position (l_s), normalized to that for a fixed position ($l_p = 0.321\lambda_g$, $l_s = 0.588\lambda_g$).



(a)



(b)

Figure 6. Measured (●)(+)(×) and theoretical (—) response for 620 GHz detector circuit. The detected power, maintaining the reference of Figure 4 is shown as a function of the parallel tuner position (l_p), for two series tuner positions (a),(b).

A theoretical model for the circuit was created and is shown in Fig. 7. The power delivered to the detector, P_n , was calculated as a function of SPB positions l_s (the SPB in series between the antenna and detectors) and l_p (the SPB in parallel with the detectors), normalized to that for reference positions l_p^r and l_s^r . These positions were $l_p^r = 0.321\lambda_g$ for the *parallel* element and $l_s^r = 0.488\lambda_g$ for the *series* element, corresponding to the positions for the measurements used to normalize the data. The theoretical response has been included with the measured data in Figures 5.8 and 5.9. While it seems there may have been some additional coupling-phenomena between the SPB and the antenna, particularly for distances of less than $\lambda_g/2$, the results appear to be consistent with theory. The theoretical range of detector impedances for which this circuit can provide an impedance match to a $24\ \Omega$ antenna is shown in Fig. 8.

IV. Conclusions

This work demonstrates at 620 GHz the fabrication and function of micromechanical tuning elements in a monolithic integrated circuit. Two micromechanical SPB's were integrated with CPW transmission lines in a quasi-optical detector circuit, and their

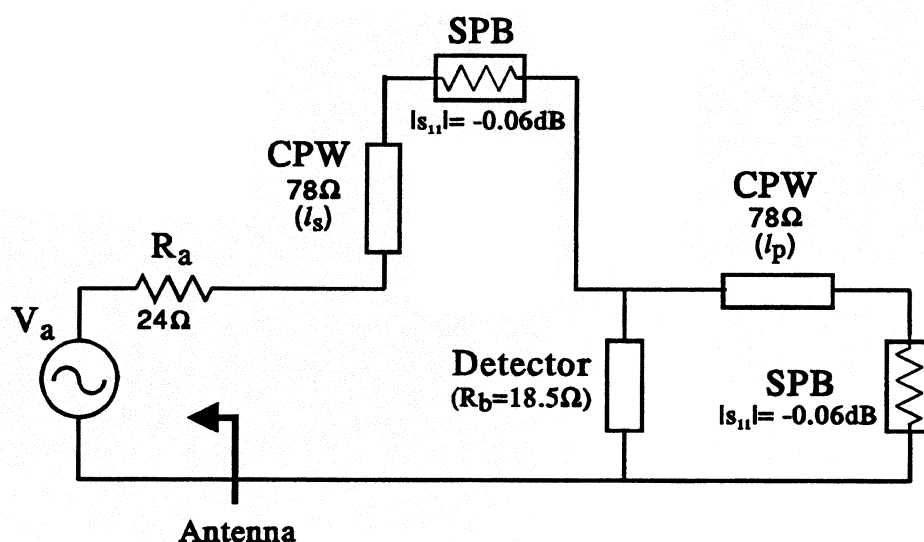

Figure 7. Schematic diagram of the equivalent circuit. Two tuning elements vary the impedance match between the antenna and detector.

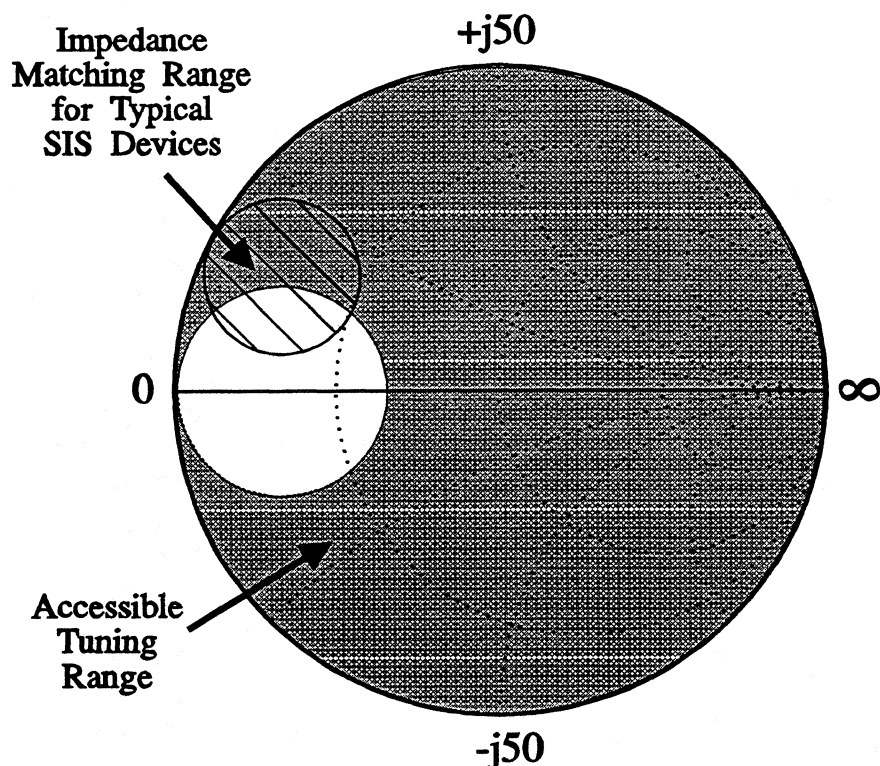

Figure 8. Smith chart showing the range of impedances to which the tuning circuit can transform a 24Ω antenna. The range is based on a lossless system, and includes impedances suitable for matching to SIS and Schottky devices.

performance measured. Performance was consistent with a theoretical model, indicating that each SPB showed a return loss of approximately -0.06 dB. The tuning elements were used to vary the power delivered to the detector over a range of almost 15 dB by adding a variable reactance in series with the antenna and a variable susceptance in parallel with the detector. Their fabrication involves processes and materials common to, and compatible with, those typically used in the production of millimeter wave and submillimeter wave integrated circuits. Such tuning elements can be implemented in a wide variety of monolithic circuit configurations, are easily scaled for use at higher frequencies, and can provide a means for post-fabrication circuit optimization.

The research described in this paper was performed by the Center for Space Mi-

croelectronics Technology, Jet Propulsion Laboratory, California Institute of Technology, and was jointly sponsored by the Innovative Science and Technology Office of the Ballistic Missile Defense Organization, and the National Aeronautics and Space Administration (NASA), Office of Space Access and Technology. V.M. Lubecke was partially supported by a NASA Graduate Student Researchers Program fellowship.

References

- [1] J. Zmuidzinas, H.G. Leduc, J.A. Stern, and S.R. Cypher, "Two Junction Tuning Circuits for Submillimeter SIS Mixers," *IEEE Trans. on Microwave Theory Tech.*, vol. 42, no. 4, pp. 698–706, April 1994.
- [2] S.S. Gearhart and G.M. Rebeiz, "A Monolithic 250 GHz Schottky-Diode Receiver," *IEEE Trans. on Microwave Theory Tech.*, vol. 42, no. 12, pp. 2505–2511, December 1994.
- [3] P.A. Stimson, R.J. Dengler, H.G. LeDuc, S.R. Cypher, and P.H. Siegel, "A Planar Quasi-optical SIS Receiver," *IEEE Trans. on Microwave Theory Tech.*, vol. 41, no. 4, pp. 609–615, April 1993.
- [4] V.M. Lubecke, W.R. McGrath, and D.B. Rutledge, "Sliding Backshorts for Planar Circuits," *International Journal of Infrared and Millimeter Waves*, vol. 12, no. 12, pp. 1387–1397, December 1991.
- [5] P.H. Siegel and R.J. Dengler, "The Dielectric-Filled Parabola: a New Millimeter and Submillimeter Wavelength Receiver/Transmitter Front End," *IEEE Transactions on Antennas and Propagation*, vol. 39, no. 1, pp. 40–47, January 1991.
- [6] G.V. Eleftheriades and G.M. Rebeiz, "Self and Mutual Admittance of Slot Antennas on a Dielectric Half-Space," *International Journal of Infrared and Millimeter Waves*, vol. 14, no. 10, October 1993.
- [7] K.C. Gupta, R. Garg, and I.J. Bahl, *Microstrip Lines and Slotlines*, Dedham, MA: Artech House, 1979.

- [8] M.Y. Frankel, S. Gupta, J.A. Valdmanis, and G.M. Mourou, "Terahertz Attenuation and Dispersion Characteristics of Coplanar Transmission Lines," *IEEE Trans. on Microwave Theory Tech.*, vol. 39, no. 6, pp. 910–916, June 1991.
- [9] T.-L. Hwang, S.E. Schwartz, and D.B. Rutledge, "Microbolometers for Infrared Detection," *Applied Physics Letters*, vol. 34, no. 11, pp. 773–776, June 1979.
- [10] D.P. Neikirk and D.B. Rutledge, "Self-heated Thermocouples for Far-Infrared Detection," *Applied Physics Letters*, vol. 41, no. 5, pp. 400–402, September 1992.
- [11] V.M. Lubecke, W.R. McGrath, D.B. Rutledge "Millimeter Wave Performance of a Sliding Planar Backshort," *SPIE International Conference on Millimeter and Submillimeter Waves and Applications-Conference Digest*, pp. 543–544, January, 1994.
- [12] V.M. Lubecke, W.R. McGrath, and D.B. Rutledge, "Micromechanical Sliding Planar Backshorts," *International Semiconductor Device Research Symposium Proceedings*, Charlottesville, VA, pp. 477–480, December 1995.