

A novel heterodyne interferometer for millimetre and sub-millimetre astronomy

Paul K. Grimes^{1,*}, Matthew Brock¹, Christian M. Holler¹, Karl Jacobs², Michael E. Jones¹, Oliver G. King¹, Jamie Leech¹, Angela C. Taylor¹ and Ghassan Yassin¹

¹*Astrophysics, Dept. of Physics, University of Oxford, Denys Wilkinson Building, Keble Road, Oxford, OX1 3RH, UK.*

²*KOSMA, I Physikalisches Institut, Universität zu Köln, Zùlpicher Straße 77, 50937, Köln, Germany*

• Contact: P.Grimes1@physics.ox.ac.uk, phone +44 1865 273304

Abstract— We describe a novel heterodyne interferometer currently under construction at Oxford. The instrument employs new techniques in heterodyne interferometry, with the aim of achieving very high brightness sensitivity in the millimetre band. It is a single-baseline tracking interferometer for operation in the frequency range 185-275 GHz with two 0.4m offset parabolic antennas separated by a 0.5 m baseline. Each antenna feeds an SIS mixer with a 2-20 GHz IF band, driven by a phase-switched LO source. The IF signals from the mixers are processed by a 2-20 GHz analogue complex correlator.

The primary science goal of this instrument is to measure the spectrum of the Sunyaev-Zel'dovich effect in galaxy clusters. In particular we intend to measure the frequency of the S-Z null near 217 GHz, which allows the gas temperature of the cluster to be determined. Measuring the spectrum of the S-Z effect requires very high brightness sensitivity with moderate spatial and spectral resolution.

I. INTRODUCTION

Cosmic microwave background astronomy requires extremely high brightness sensitivity and very good control of systematic and instrumental effects. The use of heterodyne interferometry techniques allows a number of instrumental effects to be removed, and also removes the instrumental sensitivity to total power fluctuations, suppressing the effect of atmospheric noise fluctuations. The use of heterodyne receivers also allows each receiver to be phase switched individually with the local oscillator, so that individually modulated redundant baselines can be used to eliminate instrumental effects. Achieving high brightness sensitivity in interferometry requires that the instantaneous bandwidth of each baseline be as wide as possible, and that the array be as filled as is practical within the limits of antenna shadowing.

Interferometry has been widely used in cosmology instruments at centimetre wavelengths, particularly for observations of the primary temperature anisotropy and *E*-mode polarisation of the cosmic microwave background e.g. CBI, DASI, VSA, and in observations of secondary anisotropies such as the Sunyaev-Zel'dovich effect, e.g. AMI, CBI-2, SZA.

Although measurements of the CMB and S-Z effect at millimetre wavelengths are extremely useful, the limitations of the low instantaneous (IF) bandwidth of SIS mixers and backend systems, and the poor noise performance of other mm-wave coherent detectors are responsible for the absence of successful CMB instruments using heterodyne interferometry in the high millimetre-wave band. Recent advances in SIS mixer design and wideband correlator technology make it feasible to build a mm-wave heterodyne interferometer capable of carrying out novel CMB observations.

We are currently designing and building a single-baseline 220 GHz tracking heterodyne interferometer for high brightness sensitivity interferometry for cosmology. This instrument, GUBBINS (220-GHz Ultra-BroadBand INterferometer for S-Z) will use two small antennas on a short baseline with ultra-wide IF bandwidth SIS mixers developed in collaboration with Cologne University [1] and an ultra-wideband analogue correlator developed in collaboration with the University of Maryland. After extensive laboratory testing the instrument will be deployed for test astronomical observations at the Chajnantor Observatory, Chile, adjacent to ALMA. Although the instrument will make useful scientific measurements, it will also be used for the development of new technologies for mm-wave interferometry.

The technology developed for this instrument will also have applications in other areas astronomy, particularly in the design of very wide IF bandwidth SIS receiver arrays, and in high dynamic range interferometry.

The design goals of this instrument are somewhat different to current mm-wave interferometers, in that we want to achieve maximum sensitivity to extended continuum sources with only moderate spatial and spectral resolution, but with very good control of systematics. This instrument will also be a prototype for a future S-Z spectral imaging instrument that will follow-up the very large numbers of galaxy clusters being discovered by current S-Z survey instruments.

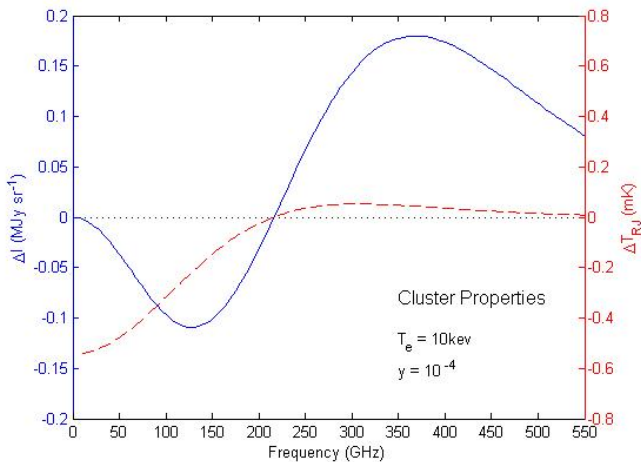

Fig.1 Spectrum of the S-Z effect in intensity (solid line, left scale) and surface brightness (dashed line, right scale) for a large cluster of galaxies. The CMB is distorted by scattering from the hot gas in a galaxy cluster. The spectral distortion due to the thermal S-Z effect has a characteristic null frequency at $217 + (0.45 T/\text{keV})$ GHz.

II. CLUSTER SCIENCE WITH GUBBINS

The Sunyaev-Zel'dovich effect is the distortion of the spectrum of the CMB due to inverse-Compton scattering off the hot gas in clusters of galaxies. This tends to boost the energy of the CMB photons, leading to a decrease in the CMB brightness below a frequency of about 220 GHz, and an increase above this frequency. One of the key features of the S-Z effect is that its surface brightness is independent of the distance to the cluster, although the angular size does of course vary. This means that S-Z measurements can be used to study galaxy clusters over a very wide range of redshifts.

The exact null frequency varies with the temperature of the cluster gas (thermal S-Z effect) and the peculiar velocity of the cluster (kinematic S-Z effect). The shift in the null frequency due to the thermal S-Z effect is approximated by $217 + 0.45T$ GHz where T is the cluster gas temperature in keV (a typical rich cluster has a gas temperature in the range 5-15 keV). Hence by measuring the SZ spectrum and finding the null frequency we can measure the cluster temperature without the need for X-ray spectral measurements.

GUBBINS will be able to detect the brightest galaxy clusters in the sky in one night's observing per cluster, and will be able to constrain the null frequency of the S-Z effect to ± 1 GHz with several nights observing. In conjunction with low frequency S-Z data e.g. from CBI-2 (26-36 GHz), we should be able to measure the cluster gas temperature to within a few keV.

These measurements are scientifically interesting and will also serve to demonstrate the application of high brightness sensitivity heterodyne interferometry at millimetre wavelengths to cosmology.

TABLE 9

OVERVIEW OF EXPECTED PERFORMANCE FOR GUBBINS PHASE I

Frequency	185-275 GHz
Antenna aperture	0.4 m
Baseline	0.5-0.6 m
Primary beam (220 GHz)	11.4' FWHM
Resolution (220 GHz)	7.5'-11.4' FWHM
IF band	3-13 GHz
Instantaneous bandwidth	2x 10 GHz
Correlator channels	16
Correlator bandwidth	2-20 GHz
Channel bandwidth	1.125 GHz
Target system temperature	50 K
Brightness sensitivity per channel	1.5 mK/ \sqrt{s}
Total brightness sensitivity	350 $\mu\text{K}/\sqrt{s}$

III. INSTRUMENT DESIGN

The specifications of the GUBBINS instrument are given in Table 9. These figures are for the initial GUBBINS design, but future upgrades are planned, in particular to increase the IF bandwidth to the full 2-20 GHz range.

The prime design targets are for a single 0.5m baseline (dictated by the angular size of the brightest S-Z clusters) with the maximum achievable filling factor; a target system temperature of 50 K; a total instantaneous bandwidth of at least 10 GHz in each sideband divided into at least 8 spectral channels and an LO tuneable by at least 20 GHz either side of the S-Z null frequency for a cold galaxy cluster at 217 GHz.

A diagram of the GUBBINS system is given in Fig 2 and a CAD model of the complete instrument in Fig 3. Both SIS receivers are mounted in a single cryostat at the centre of the instrument. This, in conjunction with the need for the maximum array filling factor and the desire to avoid any obstructions in the optical system led us to the folded offset prime focus optical design.

The designs of the various instrument subsystems are described in the rest of this section.

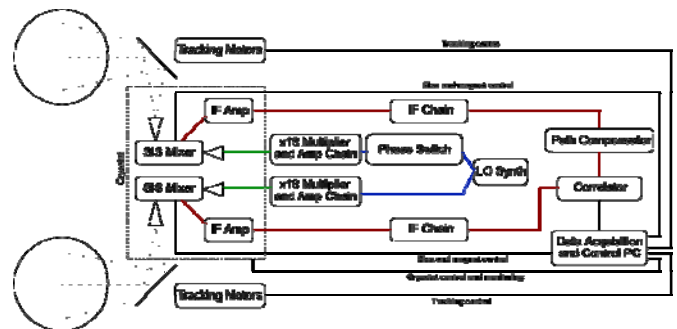

Fig.2. System diagram for the GUBBINS instrument. Data and DC signals are shown as black lines, LO signals as blue (low frequency, coaxial cables) and green (mm-wave, quasi-optical) lines and IF signals as red lines. The optics and sky signal are on the left of the diagram.

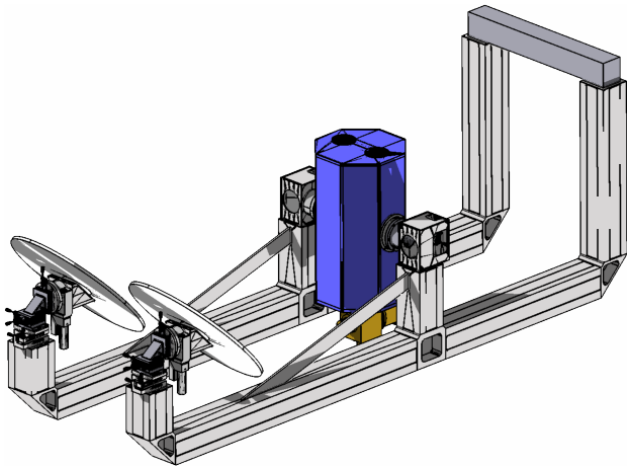

Fig.3. CAD model of the GUBBINS telescope. The telescope is supported off the cryostat body between the two optics arms. The arms are extended beyond the cryostat body and joined by a counterweight so that both arms can be driven by a single motor.

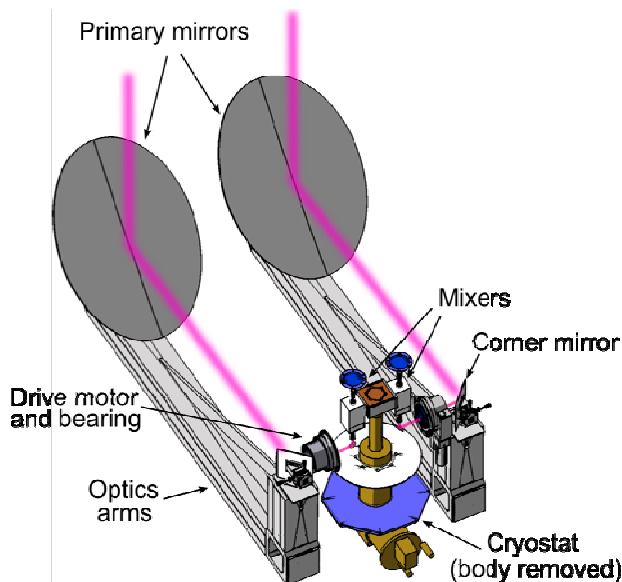

Fig.4. CAD model of the two GUBBINS optical assemblies, with the cryostat body and radiation shields and the corner mirror boxes removed, and the beams from the sky shown in pink. The optics are fed by a corrugated horn reflector (see Fig.). The beam from the horn reflector is folded through 90° by a convex (focal length -120 mm) corner mirror before going to the primary. The primary mirror is a 45° offset paraboloid with its axis perpendicular to that of the corner mirror and a focal length of 1020 mm.

A. Optics design

The optical design of each telescope employs the maximum primary mirror size that can be accommodated on a 0.5m baseline without shadowing. When both antennas are scanned to 45° from the zenith this gives a primary mirror projected aperture of ~0.4m. The optical layout is shown in Fig 4 and Fig. 6. Each telescope is fed by corrugated horn-reflector antenna with a 7° FWHM beam at 220 GHz. The primary mirror is a 45° offset paraboloid with a focal length of 1020 mm. GRASP simulations of the telescope beam are shown in Fig 5 illustrating good beam circularity and cross-polarization.

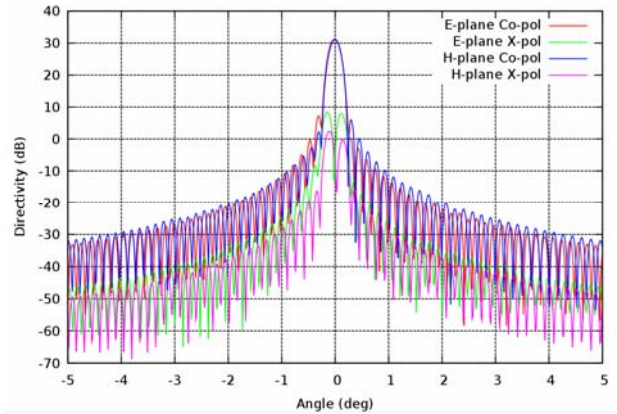

Fig.5. GRASP simulated beam of the GUBBINS telescope optics.

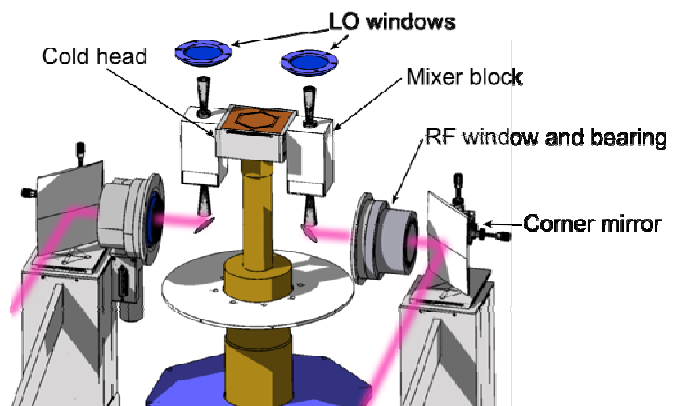

Fig.6. Layout of cryostat and corner mirror optics (Cryostat body and radiation shield removed). The beams from the sky are shown in pink. The beams from the primary mirrors are folded by the corner mirrors (extreme left and right), before passing through the motor and bearings and cryostat windows to the corrugated horn reflector antennas. LO signals are fed to the mixer blocks through windows on the top of cryostat to horns on the top of the mixer blocks. The mixer blocks are mounted on brackets to the side of the 4 K stage of the G-M cooler (gold).

In order to allow the necessary degrees of freedom in the optics so that the telescopes can be pointed in elevation and azimuth, the telescopes are folded by a 45° offset corner mirror between the primary mirror and feed. The corner mirror is a convex paraboloid (focal length -120 mm) to reduce the length of the telescopes, at the expense of introducing slight aberrations when the telescopes are pointed far from the zenith.

B. Telescope mount and cryogenics

The two arms supporting the telescopes are mounted on two ring bearings fixed around the cryostat windows, and are connected by a counterweight at the rear end of the arms (see Fig. 3). The telescopes are pointed in elevation by a single harmonic drive motor mounted to one of the ring bearings, while the telescopes are tracked across the sky by rotating the primary mirrors about the optical axis between the primary and secondary mirrors.. This allows both antennas to be pointed individually in azimuth, while keeping the number of drive components to a minimum.

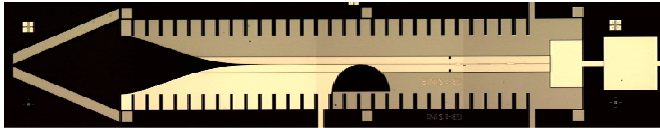

Fig. 7. Ultra-wide IF band finline SIS mixer chip described in [1], and fabricated at Cologne University by Paul Grimes and Karl Jacobs.

The whole instrument is supported on a pillar attached to the base of the cryostat and to a concrete plinth on the ground. The instrument can be mounted on the plinth in a number of orientations, allowing the projected baseline to be orientated in a number of directions.

Since the cryostat is also a structural element of the instrument mount, it is being custom designed and built by Oxford Physics. The cryostat is cooled by a two stage Gifford-McMahon cooler from Sumitomo Heavy Industries. It provides 1 W of cooling power to the 4 K stage, where the SIS mixers and first stage IF amplifiers are mounted, and 40 W to a 40 K stage where the electrical connections are heat sunk, and the second stage IF amplifiers are mounted.

C. SIS mixers and cryogenic IF amplifiers

Initially GUBBINS will use single-ended ultra-wide IF band finline mixers (Fig. 7) described elsewhere in these proceedings [1], in conjunction with a waveguide directional coupler in a split mixer block for coupling LO to the mixer.

These ultra-wide IF band mixers are based on an earlier 230 GHz finline mixer design [2], with a number of additions and improvements for ultra-wide IF band operation. An RF band-pass filter is used between the finline taper and the mixer tuning circuit to prevent the IF signal from leaking into the finline. The mixer tuning circuit and RF choke use relatively narrow microstrip lines to keep reactances in the IF band low, and a 5-stage microstrip transformer is used to match the 16.5Ω SIS junction(s) to the 50Ω input of the IF amplifiers over the 2-20 GHz IF band.

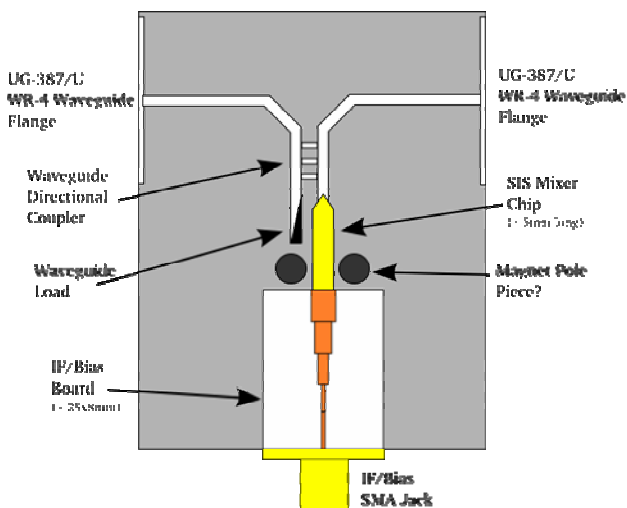

Fig. 8. Layout of the split mixer block for the single-ended finline SIS mixer for GUBBINS. Not to scale.

Using similar design techniques to those used in [4], we are developing both balanced and sideband-separating single

chip mixers in this frequency range, based on our back-to-back finline architecture, and incorporating the ultra-wide IF band technology. Once these mixer chips have been developed, GUBBINS will be the first instrument to demonstrate the use of these mixers in astronomical observations.

The split mixer block (Fig. 8) contains a -17 dB directional coupler used to combine the LO signal with the astronomical signal, a termination load to dump the uncoupled LO power and the mounting position for the SIS mixer chip. The mixer block also holds the IF transformer board used to transform the 16.5Ω output of the mixer to the 50Ω input impedance of the IF amplifier and the SMA IF/DC bias connector. A superconducting electromagnet is mounted to the block to provide the magnetic field required to suppress Josephson tunnelling in the mixer, with magnet pole pieces used to concentrate the field at the mixer chip.

The astronomical and LO signals are coupled into the mixer block via corrugated horns mounted to waveguide flanges on opposite sides of the mixer block.

The IF outputs from the mixer blocks are connected to commercial bias tees before being amplified by the first stage IF amplifiers. These amplifiers are 3-13 GHz LNAs supplied by Sander Weinreb at Caltech. They have excellent measured performance at 20 K over 10 GHz bandwidth, which should be slightly improved on further cooling to 4 K.

The biggest potential improvement in the system performance will be achieved by the use of wider band cryogenic IF amplifiers, capable of using the full 2-20 GHz bandwidth of the backend IF system. We are currently investigating a number of potential sources for these amplifiers.

D. LO system

We require two frequency-locked and 180° phase-switched LO signals to be coupled into the two SIS receivers via corrugated horns mounted on each of the mixer blocks. These horns are coupled quasi-optically through two windows on the top of the cryostat and then via two Gaussian beam telescopes to the LO source(s).

We currently have a single 195-260 GHz multiplied LO source from Radiometer Physics GmbH, and are investigating ways of generating the two required phase switched LO signals. The simplest LO solution is to purchase a second multiplied LO source and to drive both of these source with phase switched signals from a single microwave synthesized source. Since the LO source uses a x18 multiplier we have developed a 10 differential phase shift circuit which can be used with the microwave signal source used to drive the LO.

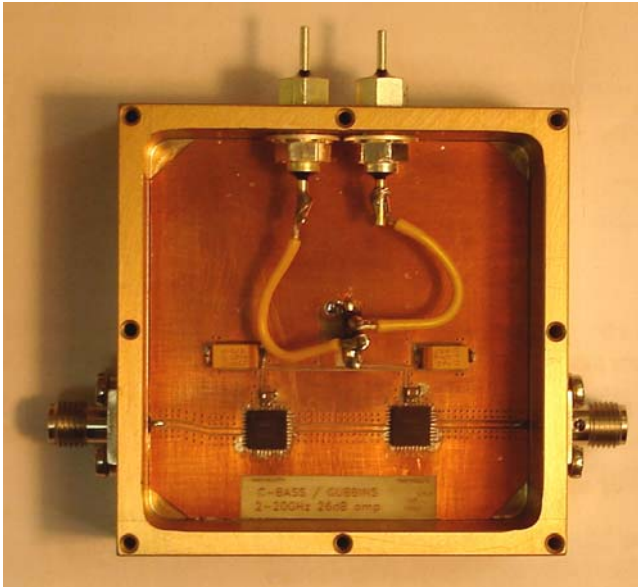

Fig.9. GUBBINS 2-20 GHz second stage IF amplifier, using two cascaded surface mount packaged amplifiers.

We will also investigate 180° phase switching the SIS receivers by switching the bias voltage of the SIS mixers from the positive to negative side of I-V curve. Since SIS mixers have antisymmetric I-V characteristics, switching the direction of the bias voltage changes the sign of the down-converted signal.

We are also working in collaboration with the Millimetre Technology Group at Rutherford Appleton Laboratories who are developing phase-locked photonic LO sources for use in SIS receivers [5]. These have the potential to greatly simplify the LO injection scheme of GUBBINS by providing individual LO sources for the SIS mixers directly coupled to mixer blocks inside the cryostat, via fibre optics feed-throughs in the cryostat walls.

We have already demonstrated that our mixer can be pumped by a RAL photonic LO system coupled quasi-optimally via the cryostat window.

E. IF chain

The IF signals from the cryogenic LNAs are then further amplified and individually processed before entering the correlator. The latter stages of IF amplification are provided by a number of gain blocks, each of which uses two Hittite HMC462LP5 2-20 GHz 13 dB cascaded amplifiers in surface mount packages (Fig. 9). These gain blocks show excellent performance for a relatively low cost device (~\$70 per amplifier chip), with a noise figure of 2.5 dB at room temperature, which is significantly improved on cooling the gain block to 77 K. To ensure that the noise figure of the first of these gain blocks has minimal effect on the overall system noise, the first gain block will be mounted on the 40 K stage of the cryostat.

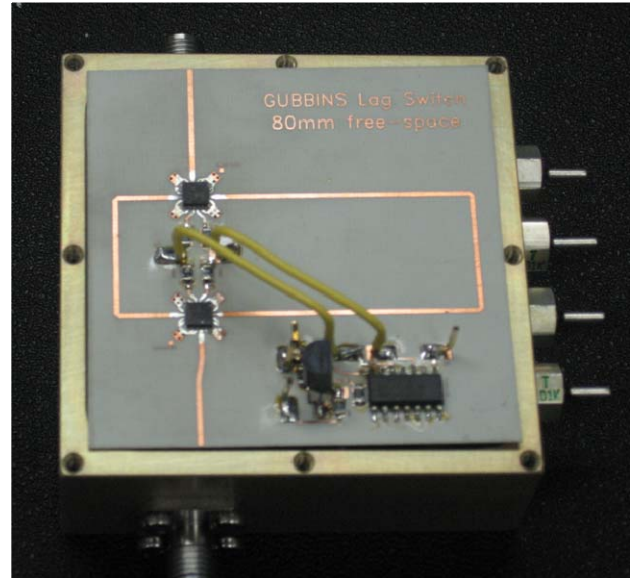

Fig.10. GUBBINS 80mm path compensator bit. This component provides a switchable path delay to compensate for the difference in path length created by tracking the antennas.

As well as being amplified, the IF signals are also band-pass filtered and have slope compensation applied across the IF band. The final step before correlation is to apply path compensation to the signal to remove the path delay introduced by scanning the two antennas of the telescope. The path compensator is made up of five lag switches (Fig. 10), providing 10, 20, 40, 80 and 160 mm of path compensation, and made up of differential lengths of microstrip line switched by Hittite HMC547 0-20 GHz FET switches supplied in surface mount packages.

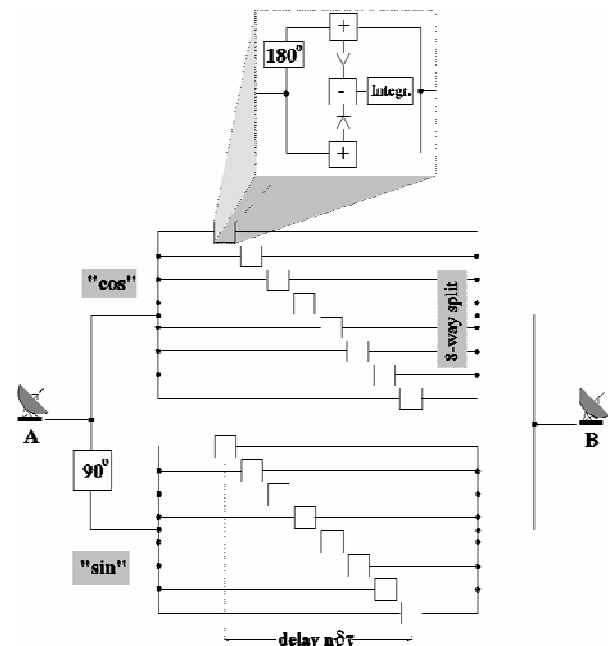

Fig.11. Diagram of a 16 lag complex Fourier transform correlator. In the GUBBINS correlator the 180° phase shifter and two diode detectors in each lag are replaced by a Gilbert Cell multiplier MMIC chip.

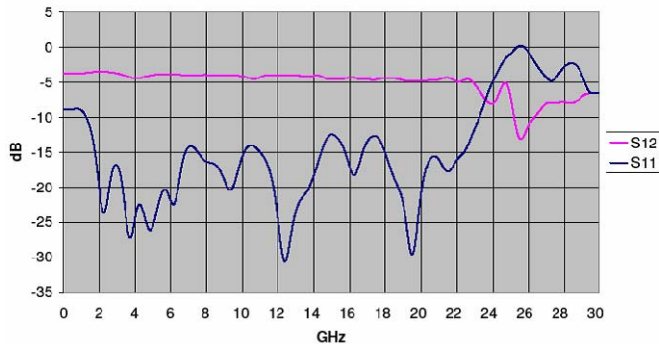
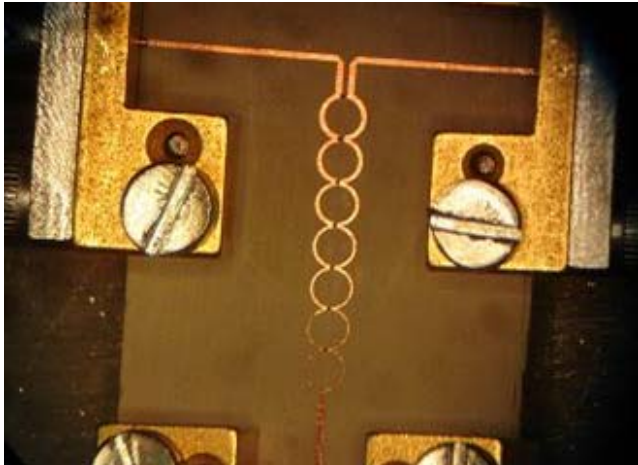

Fig.12. Photo (top) and measured performance (bottom) for the Wilkinson power splitter developed for the GUBBINS correlator. The splitter shows good transmission (S12) from 0 to 23 GHz and good return loss (S11) from 2-23 GHz.

F. Correlator and data acquisition

The IF signals from the two antennas are combined in an analogue correlator developed at Oxford in collaboration with Andrew Harris at University of Maryland. The correlator is a complex Fourier transform lag correlator with 16 channels, with the full 2-20 GHz bandwidth being processed simultaneously, rather than being split into sub-bands. The architecture of the correlator is shown in Fig. 11.

The IF signal from one antenna is split in a commercial quadrature hybrid, with other split in phase using a Wilkinson power divider, before being fed to two 8 lag correlator boards. The two signals on each board are then split eight ways using Wilkinson power divider trees before they are combined and detected by Gilbert Cell multiplier MMIC chips.

The Wilkinson power dividers are a seven-stage design fabricated on Rogers 6010LM with an Ohmega Ply 50 Ω/\square resistive sheet under the copper (Fig. 12). The microstrip lines are etched first, with the resistive elements defined in a second etching step. These dividers show excellent performance from 1.5-23 GHz.

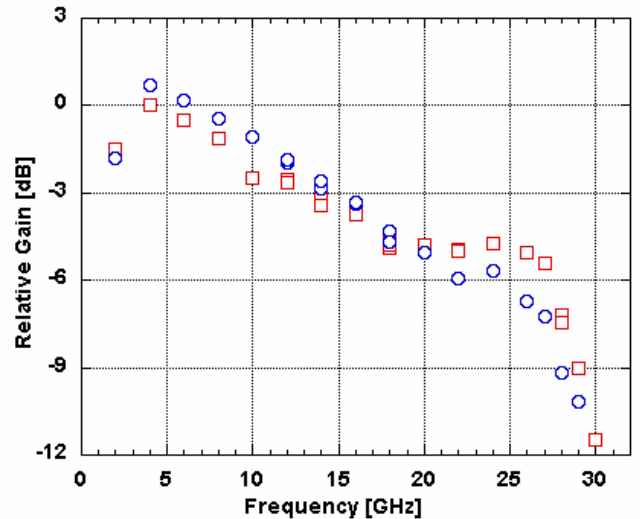
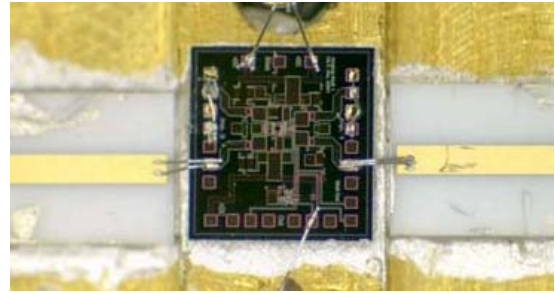

Fig.13. Photo (top) and measured performance (bottom) of the Gilbert Cell multiplier chip developed by Andrew Harris at University of Maryland and Steve Maas at Nonlinear Technologies Inc[3]. The multipliers show good performance from 3-27 GHz.

The Gilbert Cell multiplier MMICs are used to both combine the two IF signals and to detect the combined signal. These devices (Fig. 13) were developed by Andrew Harris at University of Maryland and Steve Maas at Nonlinear Technologies Inc. [3]. These devices provide both the sum and difference measurements of the combined signals, each replacing two power splitters, a 180° phase shift and two detector diodes in a conventional diode detector correlator.

The multiplier chips are read by low noise amplifiers and an A-to-D conversion board developed by the Oxford Central Electronics Group. This board uses 2.8 MSps ADCs from Linear Technology feeding a Vertex FPGA processor and provides a USB output to the data acquisition computer. The readout boards and individual correlator components are now fully tested, and the first 4 lag correlator board (Fig. 14) is currently under construction at Oxford.

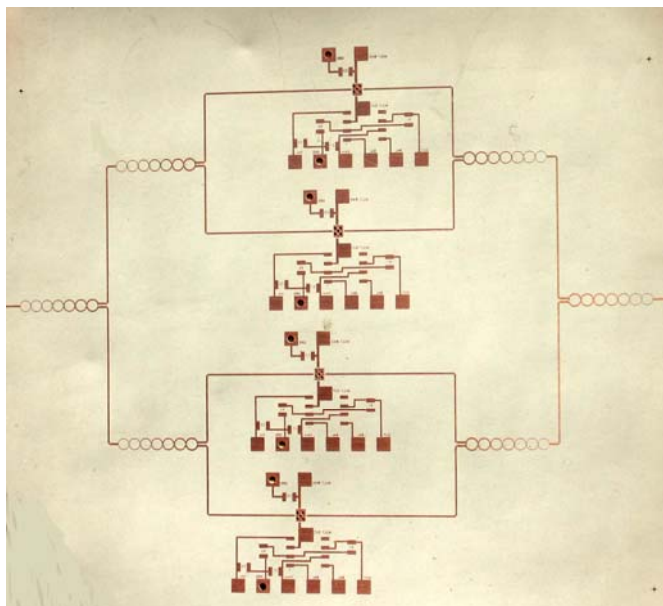

Fig.14. Unpopulated prototype correlator board. This board has four lag steps and will be used for initial testing of the correlator design.

CONCLUSIONS

We are designing and building a single-baseline mm-wave heterodyne interferometer with exceptional brightness sensitivity. This instrument will accommodate many of the new technologies we are currently developing, particularly ultra-wide IF band SIS mixers, ultra-wide band analogue correlators and phase switched photonic LO sources.

There is a niche for a future mm-wave interferometer with exceptional brightness sensitivity and wide field of view, complementary to ALMA and large mm-wave single dish telescopes, with key science goals of following up on the large numbers of S-Z clusters detected by current surveys, and for wide field imaging of faint extended continuum sources over wide frequency ranges. GUBBINS is intended to be an initial proving ground for the technology required for such an instrument.

ACKNOWLEDGEMENTS

We are grateful to the Royal Society for funding the construction of this instrument under the Paul Instrument Fund scheme.

REFERENCES

- [1] P.K. Grimes, G. Yassin and K. Jacobs, "Design of finline SIS mixers with ultra-wide IF bands", in *Proc. 19th Int. Symp. Space THz Tech.*, P3-3, 2008.
- [2] G. Yassin, R. Padman, S. Withington and K. Jacobs, "A broad band antipodal finline mixer for astronomical imaging arrays", *Electron. Lett.*, vol. 33, pp 498-500, 1997.
- [3] A. Harris, "Gilbert Cell Multiplier Measurements III: Response from 2-30 GHz", University of Maryland Internal Technical Report, 2002. More complete information on these multipliers is currently available from <http://www.astro.umd.edu/~harris/spectrum.html>
- [4] P.K. Grimes, G. Yassin and S. Withington, "A 700 GHz single chip balanced SIS mixer", in *Proc. 16th Int. Symp. Space THz Tech.*, 2005.
- [5] A.L. Fontana, Y. Bortolotti, B. Lazareff, A. Navarrini, P.G. Huggard and B.N. Ellison, "Cryogenic photonic local oscillator for 2 mm band SIS heterodyne astronomical receiver array", *Electron. Lett.*, **43**, 20, 2007.