

# Towards Multi-Pixel Heterodyne Terahertz Receivers

Victor Belitsky, Vincent Desmaris, Dimitar Dochev, Denis Meledin, Alexey Pavolotsky

**Abstract**— Terahertz multi-pixel heterodyne receivers introduce multiple challenges for their implementation, mostly due to the extremely small dimensions of all components and even smaller tolerances in terms of alignment, linear dimensions and waveguide component surface quality. In this manuscript, we present a concept of terahertz multi-pixel heterodyne receiver employing optical layout using polarization split between the LO and RF. The frontend is based on a waveguide balanced HEB mixer for the frequency band 1.6 – 2.0 THz. The balanced HEB mixer follows the layout of earlier demonstrated APEX T2 mixer. However for the mixer presented here, we implemented split-block layout offering minimized lengths of all waveguides and thus reducing the associated RF loss. The micromachining methods employed for producing the mixer housing and the HEB mixer chip are very suitable for producing multiple structures and hence are in-line with requirements of multi-pixel receiver technology. The demonstrated relatively simple mounting of the mixer chip with self-aligning should greatly facilitate the integration of such multi-channel receiver.

**Index Terms**— Instrumentation, Multi-pixel, Terahertz, Waveguide Balanced Mixer.

## I. INTRODUCTION

AN airborne observatory such as SOFIA [1], or a space observatories as Herschel [2] and Plank [3] allow to reduce or eliminate atmospheric absorption for observations in the terahertz frequency band. Moreover, high altitude and dry sites such as Dome C in Antarctica [4], Llano de Chajnantor [5, 6] and Cerro Chajnantor [7] in Chile could provide reasonable atmospheric transmission at THz frequencies thus making them suitable for technology testing and radio astronomical observations from the ground [5, 8] over limited periods of time when PWV is less than 0.1 mm giving possibilities to observe in the 1.5 THz frequency window from the ground.

The current generation of Terahertz receivers installed at the radio-telescopes uses single-pixel heterodyne instruments. Aiming increased observation efficiency through use of multi-pixel heterodyne instruments, called sometimes “science

multipliers”, become an actual option for new ground-based telescopes such as Dom C or CCAT [9]. Such multi-pixel Terahertz heterodyne instruments should allow doing more science during very limited time available for effective Terahertz observations from the ground and use flight time of SOFIA efficiently.

Heterodyne instrumentation for the THz ground-based telescopes, airborne and space observatories has made remarkable progress during the last two decades bringing SIS and HEB mixer technology to its ultimate state [10-12]. Often above 1 THz, a quasioptical HEB mixer design with planar antenna and substrate lens [13, 14] is used. Alternatively, waveguide HEB mixers have been also demonstrated [5, 8, 15, 16] offering superior efficiency of the receiver-antenna coupling via a corrugated horn. Furthermore, waveguide designs present a natural filtering for the out-of-the-band background noise, feature especially useful for easily saturated HEB mixers. When installed at the ground-based telescopes, the atmospheric contribution to the background noise remains close to 300 K at terahertz frequencies and could cause saturation with rather weak control over RF band as in, e.g., quasioptical HEB mixers. Additionally, THz receivers have to cope with the relatively low attainable power of local oscillator (LO) sources and its sufficiently high sideband noise [17], problems, which are multiplied by a number of pixels, at least, for a multi-pixel system. These problems could be circumvented by employing a balanced layout, which offers extremely high efficiency of using the LO power (around 3 dB loss only) and provides improved receiver stability by intrinsic cancellation of the LO amplitude noise as it was demonstrated in [5].

The dimensions of all components are scaled down with the frequency and for Terahertz frequencies, e.g., around 1.3 THz the waveguide dimensions are  $90 \times 180 \mu\text{m}$  [5] and required even smaller, nearly sub-micron, design tolerances. The size of the corrugated feed becomes smaller too and comparable with e.g. the size of the SMA contact. This implies a demand to find new approaches for the optical layout where the RF/LO part of the receiver could be separated from IF/DC interface.

Micrometer scale dimensions and tolerances introduce increasing challenges for fabrication using conventional machining and call for applying a micro machining technology, e.g., terahertz all-metal waveguides [18, 19].

In this manuscript, we present a concept of terahertz multi-pixel heterodyne receiver employing optical layout using polarization split between the LO and RF. The frontend is based on a waveguide balanced HEB mixer for the frequency

Manuscript received June 19, 2011. This work was partly supported by the European Commission Framework Programme 7 via RadioNet, JRA AMSTAR+, Grant No. 227290.

Authors are with the *Group for Advanced Receiver Development*, Department of Earth and Space Sciences with Onsala Space Observatory, Chalmers University of Technology, Gothenburg, SE 412 96, Sweden (corresponding author Victor.Belitsky@chalmers.se, phone +46-31-772 1000).

band 1.6 – 2.0 THz. Additionally, we investigate possibilities for a simplified and accurate mounting, and electrical interfacing of the HEB mixer substrate by utilizing a novel HEB mixer chip layout [20].

## II. TERAHERTZ MULTI-PIXEL RECEIVER CONCEPT

### A. Optical Layout

Focal plane heterodyne multi-pixel systems are not background limited and that implies specific pitch for placing the feeds of each pixel while each pixel's optics should be matched to the antenna [21]. With the given feed size, at Terahertz frequencies, physical dimensions of the array following optimal pitch leave no room for the IF system assuming realistic dimensions of SMA connectors and IF amplifiers. As discussed in the introduction, we need a receiver layout that provides a possibility to separate optics, with pixel feed corrugated horn and LO distributing and injection system, and the IF/DC system with its bulky (compare to Terahertz mixers) IF amplifiers and DC and IF connectors.

Additional problem to consider is potential complexity of the LO distribution and injection system. Most likely, the LO power of a few tens of microwatt could be expected from Terahertz LO source [22]. In order to preserve as much LO power as possible, such system should have individual LO feed for each pixel. For LO injection, using a beam-splitter option either leads to an unacceptable LO power loss (under-pumped mixers) or increased RF signal damping (high optical RF loss). In either case it would be detrimental to the receiver performance. On our view, a possible solution of combining the LO and RF at the optical path would be using a grid polarizer; this will produce the input beam with orthogonally polarized LO and RF while providing virtually no insertion loss at RF and no injection loss for the LO. Such system depicted in Figure 1.

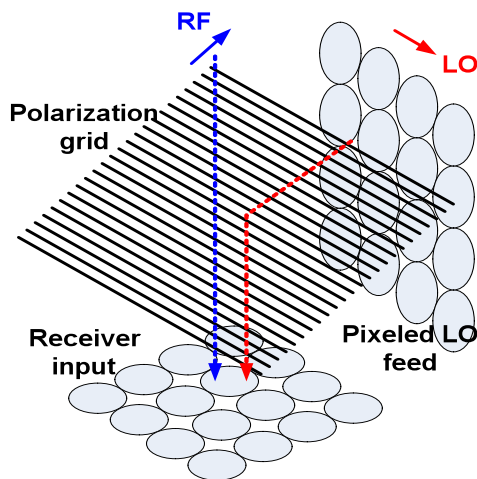

Fig. 1. Proposed optical layout for Terahertz multi-pixel receiver. In order to preserve the LO power, the LO feed is has RF-signal-matched pixel structure. A polarization grid is used to combine the LO and RF with minimum loss. The incoming signal has the LO and RF orthogonally polarized.

The advantages of the system depicted in Figure 1 are the

following:

- Separation of the RF/LO and IF/DC interfaces that ease design, and integration of the entire receiver;
- Minimum insertion loss for RF and LO in the quasioptical part;
- Physical separation of the RF and LO feed systems that ease design and integration;

### B. Frontend Concept for Single Pixel

In order to use such optical layout, the frontend design should be modified to receive both polarizations; each pixel mixer should have polarization splitter (e.g., OMT) to separate the RF and LO; the mixer should have two separate inputs for the RF and LO signals. The latter is an inherent feature of the waveguide balanced mixer demonstrated earlier [5] and has additional advantage of very effective use of the LO power while suppressing the LO AM noise. Schematically, the single pixel frontend with the feed and the LO/RF separation and injection part is presented in Figure 2.

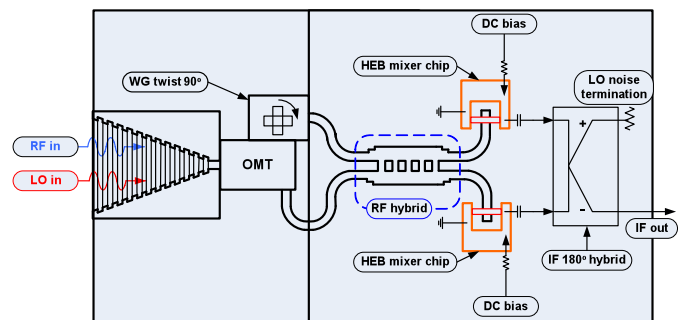

Fig. 2. Proposed pixel layout for Terahertz multi-pixel receiver. Input corrugated horn converts both LO and RF input beams into orthogonal waveguide modes; the waveguide modes are separated by OMT; balanced waveguide mixer is connected to the OMT outputs either directly or via 90-degree waveguide twist.

Clearly, in order to accommodate two orthogonally polarized RF and LO signals, the pixel frontend should have more complex design - as depicted in the Figure 2; the LO/RF separation scheme would introduce insertion loss for both RF and LO; additional components such as OMT and 90-degree waveguide twist should be fabricated and integrated with the mixer for each pixel. The latter two components were of interest for other research groups and their results [23 – 25] show good compatibility with micromachining approach [18, 19] and thus give a hope for successful implementation.

### C. Waveguide Balanced HEB Mixer for 1.6 – 2.0 THz

As discussed above and demonstrated in [5], a balanced mixer layout gives several important advantages:

- Balanced design preserves most of the LO power;
- Balanced design has separate LO port, which is convenient and is required for the LO injection scheme suggested here;
- Balanced scheme rejects the LO AM noise and background additive noise and that is increasingly important assuming the LO multiplication stages are pumped extremely heavily at Terahertz frequencies.

For multi-pixel application, the balanced waveguide mixer

should preferably have split-block layout. This is especially important in the view of reproducing many pixels where the split-block should provide a possibility of simultaneous access to several pixels in contrast to, e.g., end-piece configuration. In split-block layout all lead waveguides could be made of minimum length to minimize insertion loss and thus contributing to the system noise performance. Finally, in the split-block configuration, it is easier to achieve a compact design reducing the mixer foot-print required due to a smaller physical size of the feed and, consequently, enabling a tighter pixel packing at Terahertz frequencies.

Mounting and electrical connections of the chip in the mixer block and an easy way of integrating active mixer component, e.g., HEB mixer, have strong effect on the ability to build multi-pixel heterodyne receiver at Terahertz frequencies. A very tiny, thin and fragile substrate of a HEB mixer precludes using wire-bonding and introduces a great challenge of mounting. In order to circumvent these problems, we use novel layout [20] comprising supporting  $\Pi$ -frame for electrical contacts and used as mechanical reference for mounting in the mixer block. Figure 3 depicts the  $\Pi$ -frame chip compatible with the split-block layout.

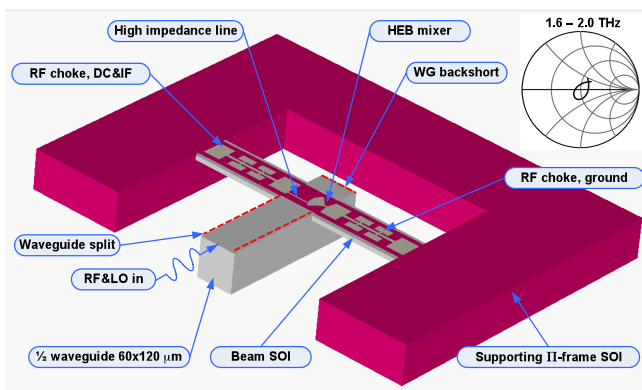

Fig. 3. An illustration of the HEB mixer chip with supporting  $\Pi$ -frame. This layout is fully compatible with the split-block technique and dramatically eases mounting and electrical contacting to the mixer chip allowing, e.g., a wire-bonding to the contact pads (not shown) deposited on the beam supporting frame. The insert shows matching of the probe to the waveguide over the 1.6 to 2.0 THz band.

In order to fabricate such structure, we used double-bonded SOI (silicon-on-insulator) substrate. The top layer, of 2.0  $\mu\text{m}$  thick high-resistivity silicon, defines the thickness of the beam where the HEB mixer is placed. In order to pattern the mixer and shape the substrate, we used optical- and E-beam lithography, sputter thin film deposition and Si dry etching. Details of the processing and NbN film deposition could be found in [20]. As a result, the structure depicted in Figure 3 was fabricated and integrated into the waveguide balanced mixer block designed for 1.6–2.0 THz band and manufactured using all-metal Terahertz waveguide technique, GARD-process [17, 18, 5]. After mounting the mixer chips their alignment was checked using SEM imaging: the accuracy of the mixer chip placement was within  $\pm 2 \mu\text{m}$  and the mounting was performed within less than 10 min per chip. Figure 4 shows SEM picture of the mixer chip mounted into

the mixer mount, the waveguide dimensions are  $60 \times 120 \mu\text{m}$ .

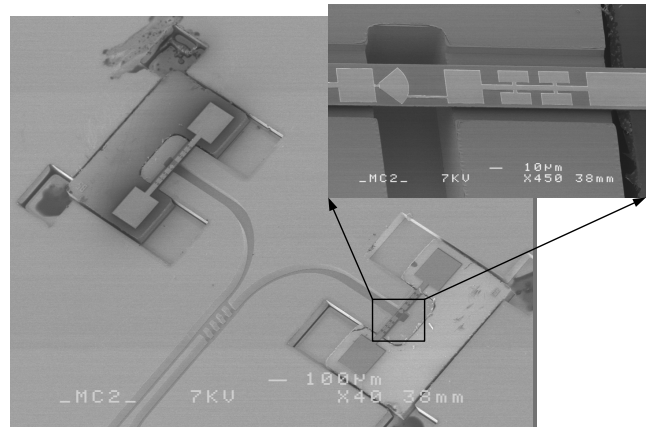

Fig. 4. SEM picture of the fabricated mixer mount with layout presented in Figure 2 and the two HEB mixer chips integrated. No wire bonding for DC/IF interfacing was made. The insert shows SEM picture with magnified view of the HEB mixer beam crossing the waveguide.

It is worth mentioning that the presented mixer layout greatly facilitates mounting and aligning of the HEB devices in the mixer block. Alignment relies on photo-lithography-defined dimensions of the HEB beam, frame and the mixer block structure. Through this, the entire mounting procedure becomes self-aligning. The GARD-process, used for the fabrication of all-metal waveguide structure, is a lithographic process with inherent dimension accuracy better than  $1 \mu\text{m}$ , and hence can replicate identical waveguide mixer block structures over, e.g., a 4'' wafers. Its combination with the novel type of HEB chips provides easy handling and alignment possibilities and opens the way for realization of multi-pixel THz waveguide receivers.

### III. CONCLUSION

In this paper, we presented a concept of multi-pixel heterodyne receiver employing a grid polarizer to inject LO signal into the receiver RF beam. Such scheme offers convenience of designing and building optics and IF/DC interfaces. This approach however requires additional waveguide circuitry comprising an OMT and a waveguide 90-degree twist for each pixel and could be manufactured using micro-fabrication and micro-machining techniques. For the mixers, we suggest using a balanced waveguide hot-electron bolometer mixer. A technology demonstrator employing a novel layout for the HEB mixer with supporting  $\Pi$ -frame and operating in the 1.6 - 2.0 THz band was presented. The design combines several key technologies: all-metal THz waveguide micromachining, ultra-thin NbN deposition and a micromachining of SOI substrate to manufacture the HEB mixer. Integration of the chip into the mixer relies on self-aligning and provides mounting accuracy within  $\pm 2 \mu\text{m}$  confirmed via SEM measurements. As it looks from the mixer fabrication point of view, the number of pixels would be rather constrained by a possibility to generate enough LO power. Given achieved dimensions' accuracy, mounting and alignment tolerances, the demonstrated approach should be

suitable for building multi-pixel and single-end deep-terahertz mixers operating at up to 5 THz.

#### ACKNOWLEDGMENTS

Authors would like to thank S.-E. Ferm for his remarkable fine-mechanic work in this project.

Onsala Space Observatory, Swedish National Facility for Radio Astronomy, contributing 50% of the funds for these studies via RadioNet AMSTAR+.

#### REFERENCES

- [1] SOFIA: Stratospheric Observatory for Infrared Astronomy, <http://www.sofia.usra.edu/index.html>.
- [2] Herschel Observatory, <http://herschel.esac.esa.int/>.
- [3] Planck Observatory, <http://www.esa.int/esaMI/Planck/index.html>.
- [4] N. Schneider, V. Minier, G. Durand, P. Tremblin, J. Urban, and P. Baron, "Atmospheric Transmission at Dome C between 0 and 10 THz," EAS Publications Series, vol. 40, pp. 327–332, 2010.
- [5] D. Meledin, A. Pavolotsky, V. Desmaris, I. Lapkin, C. Risacher, V. P. Robles, D. Henke, O. Nyström, E. Sundin, D. Dochev, M. Pantaleev, M. Fredrixon, M. Strandberg, B. Voronov, G. Gol'tsman, and V. Belitsky, "A 1.3 THz balanced waveguide HEB mixer for the APEX telescope," IEEE Trans. Microwave Theory Tech., vol. 57, pp. 89–98, 2009.
- [6] J. R. Pardo, E. Serabyn, and J. Cernicharo, "Submillimeter atmospheric transmission measurements on Mauna Kea during extremely dry El Nino conditions: implications for broadband opacity contributions," J. Quant. Spectrosc. Radiat. Transf., vol. 68, pp. 419–433, 2001.
- [7] S. Paine, R. Blundell, D. C. Papa, and J. W. Barrett, "A Fourier transform spectrometer for measurement of atmospheric transmission at submillimeter wavelengths," PASP, vol. 112, pp. 108–118, 2000.
- [8] D. P. Marrone, R. Blundell, E. Tong, S. N. Paine, D. Loudkov, J. H. Kawamura, D. Lühr, and C. Barrientos, "Observations in the 1.3 and 1.5 THz atmospheric windows with the receiver lab telescope," in 16<sup>th</sup> Int. Symp. Space Terahertz Technol. Göteborg, Sweden, 2005.
- [9] The Cornell Caltech Atacama Telescope (CCAT), <http://submm.org/>.
- [10] G. de Lange, "Development of the HIFI band 3 and 4 mixer units," Proc. SPIE Int. Soc. Opt. Eng., vol. 5498, pp. 267–277, 2004.
- [11] G. H. Tan, "The ALMA front ends: an overview," in Proc. 19<sup>th</sup> Int. Symp. Space Terahertz Technol., Groningen, 2008.
- [12] V. Belitsky, I. Lapkin, V. Vassilev, R. Monje, A. B. Pavolotsky, D. Meledin, D. Henke, O. Nyström, V. Desmaris, C. Risacher, M. Svensson, M. Olberg, E. Sundin, M. Fredrixon, D. Dochev, S.-E. Ferm, and H. Olofsson, "Facility Heterodyne Receiver for the Atacama Pathfinder Experiment Telescope," in Joint 32<sup>nd</sup> Int. Conf. Infrared Millimeter Waves and 15<sup>th</sup> Int. Conf. Terahertz Electronics Cardiff, UK, 2007.
- [13] P. Khosropanah, J. R. Gao, W. M. Laauwen, M. Hajenius, and T. M. Klapwijk, "Low noise NbN hot electron bolometer mixer at 4.3 THz," Appl. Phys. Lett., vol. 91, p. 221111, 2007.
- [14] S. Cherednichenko, V. Drankinskiy, T. Berg, P. Khosropanah, and E. Kollberg, "Hot-electron bolometer terahertz mixers for the Herschel Space Observatory," Rev. Sci. Instr., vol. 79, p. 034501, 2008.
- [15] D. Meledin, D. P. Marrone, C.-Y. E. Tong, H. Gibson, R. Blundell, S. N. Paine, et al, "A 1 THz superconducting Hot Electron Bolometer receiver for astronomical observations," IEEE Trans. Microwave Theory and Techniques, vol. 52, no.10, pp. 2338–2343, Oct. 2004.
- [16] E. Tong, J. Kawamura, D. Marrone, D. Loudkov, S. Paine, R. Blundell, C. Barrientos, and D. Lühr, "A 1.5 THz hot electron bolometer receiver for ground-based terahertz astronomy in northern Chile," Proc. SPIE, vol. 6373, 2006.
- [17] J. W. Kooi and V. Ossenkopf, "HIFI instrument stability as measured during the thermal vacuum tests of the Herschel space observatory," Proc. 20<sup>th</sup> Int. Symp. Space THz Technol., 2009.
- [18] A. Pavolotsky, D. Meledin, C. Risacher, M. Pantaleev, and V. Belitsky, "Micromachining approach in fabricating of THz waveguide components," Microelectron. J., vol. 36, p. 636, 2005.
- [19] V. Desmaris, D. Meledin, A. Pavolotsky, R. Monje, and V. Belitsky, "All-metal micromachining for the fabrication of sub-millimetre and THz waveguide components and circuits," J. Micromech. Microeng., vol. 18, p. 095994, 2008.
- [20] D. Dochev, V. Desmaris, D. Meledin, A. Pavolotsky, V. Belitsky, "A Technology Demonstrator for a 1.6 – 20 THz Waveguide HEB Receiver with a Novel Mixer Layout", Int. Journal of Infrared, Millimeter and Terahertz Waves, vol. 32, No. 4, pp 451-465, April 2011. (doi: 10.1007/s10762-011-9774-9).
- [21] J.F. Johansson, "Millimetre Wave Imaging – Theory and Experiments", Research Report No. 151, Department of Radio and Space Science, Chalmers Univ. of Technology, Gothenburg, Sweden, May 1986.
- [22] J. V. Siles, B. Thomas, G. Chattopadhyay, A. Maestrini, C. Lee, E. Schlecht, C. Jung and I. Mehdi, "Design of a high-power 1.6 THz Schottky tripler using 'on-chip' power-combining and Silicon micro-machining", Proceedings of 22<sup>nd</sup> International Symposium on Space Terahertz Technology, Tucson, 26-28 April 2011.
- [23] Christopher E. Groppi, Christian Y. Drouet d'Aubigny, Arthur W. Lichtenberger, Christine M. Lyons, Christopher K. Walker, "Broadband Finline Ortho-Mode Transducer for the 750-1150 GHz Band", Proceedings of 16th International Symposium on Space Terahertz Technology, pp.513-518, May 2-4, 2005, Chalmers University of Technology, Göteborg, Sweden.
- [24] G. Chattopadhyay, J. Ward, N. Llombert, and K. Cooper, "Submillimeterwave 90. Polarization twists for integrated waveguide circuits," IEEE Microw. Wireless Compon. Lett., vol. 20, no. 11, pp. 592–594, Nov. 2010.
- [25] Lihan Chen, Alex Arsenovic, James R. Stanec, Theodore J. Reck, Arthur W. Lichtenberger, "A Micromachined Terahertz Waveguide 90 Twist", IEEE Microw. Wireless Compon. Lett., vol. 21, no. 5, pp. 234–236, May 2011.