

COPY

General Electric Co., Ltd.
Magnet House
Kingsway, London, W.C.2

Ref. OV/DES

29th October, 1947

The U. S. Department of Commerce,
National Bureau of Standards,
Washington,
U.S.A.

Dear Sirs,

In reply to your letter of the 21st instant we have pleasure in enclosing technical data on our DET. 22 and DET. 23 together with three other types which we think may be of interest to you, MAG. 2, ACT. 22 and ACT. 23. The prices for these valves are as follows:

DET. 22	£8.	2.	0.
DET. 23	£10.	16.	0.
MAG. 2	£15.	10.	6.
ACT. 22	£50.	0.	0.
ACT. 23	£50.	0.	0.

Delivery of DET. 22 and DET. 23 and MAG.2 for small quantities can be given in about 21 days from receipt of order, ACT. 22 and 23 about 6 weeks.

Trusting that this information will be of some use to you and assure you at all times of our very best attention.

Yours faithfully,
For and on behalf of
The General Electric Co., LTD.

/s/ (OV/DES)
Osram Valve Department

Supplementary
conditions of sale attached



VALVES

MADE IN ENGLAND

*This is same tube as Mullard *ME1001*

DET22 U.H.F. TRIODE

DESCRIPTION

Type DET 22 is an indirectly heated disc seal triode (without internal feedback) intended mainly as a common grid, earthed anode, concentric line oscillator. It may also be used as a power amplifier.

When used in a co-axial line circuit with an anode input of 10 watts, the output power is approximately 0.5 watts at 10 cms. rising to 3 watts at 30 cms.

The lower limit of operating wavelength is 8—8.5 cms.

RATINGS

Heater Voltage	6.3	
Heater Current	0.4	amps.
Anode Voltage	350	max
Anode Dissipation	10	watts max.
Mean Anode Current	40	mA. max.
Peak Anode Current	150	mA. max.
Amplification Factor	30	approx.
Mutual Conductance measured at $V_a=250$; $I_a=20$ mA.	6.0	mA./volt
Anode Seal Temperature	140	°C. max.

Capacitances :

Grid to Cathode	2.2	pF approx.
Anode to Grid	1.1	" "
Anode to Cathode	0.02	" "

PRECAUTIONS IN USE

In order to limit the anode seal temperature, and also to limit the rate of change of anode seal temperature, it is necessary for the mass of metal in close thermal contact with the anode disc to be not less than 2 ozs. (approx. 60 gms.) of brass or its equivalent.

DIMENSIONS

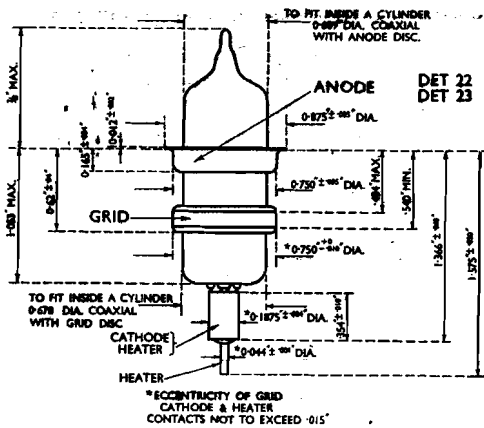

Fig. 1

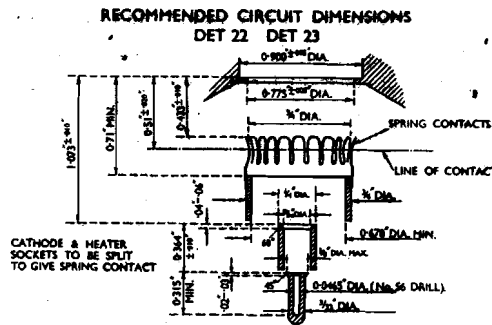

Fig. 2

TYPE DET22

CIRCUIT DESIGN

A typical circuit arrangement is shown in Fig. 5 where the anode-grid and grid-cathode circuits are both co-axial lines, the grid tube being common to both circuits.

The anode-grid and grid-cathode circuits are both tuned by means of movable bridges, and it is essential that good contact be maintained between these bridges and the tubes on which they slide. Ideally these bridges should be one quarter of a wavelength in length, in order that the actual contact may occur at a current node, but over the wavelength range of 10—60 cms. a good compromise is effected with a bridge 2.5 cm. in length. In order that bias may be used, a capacity is incorporated in the grid-cathode bridge.

Feedback is obtained by means of a probe (6 B.A. threaded rod) which makes contact with the anode line and passes through a $\frac{1}{4}$ " diameter hole in the grid line. The displacement of the end of the probe from the cathode tube is thus readily adjustable. For wavelengths longer than 30 cms. it is desirable to terminate the probe by a small circular plate, but for wavelengths below 30 cms. the plate may be dispensed with, and for wavelengths around 10 cms. the increased capacity prohibits its use.

The output may be taken from the oscillator into a 75 ohm. cable by means of a capacity probe, as indicated in Fig. 5. The coupling can be adjusted to optimum by sliding the probe along the line or by varying the depth of penetration towards the grid line.

The complete range of oscillation between the lower wavelength limit (determined by the valve or the circuit) and the upper wavelength limit (determined by the circuit) is not possible with a single probe position. A complete range of oscillation can be obtained with three probe positions, and for a typical circuit and the probe positions marked "A," "B" and "C" in Fig. 5 the range of wavelengths that was obtained is given in the following table:—

Probe Position.	Distance from Anode Plane	Range of λ with Anode Line on $\frac{3\lambda}{4}$ mode.	Min. λ with Anode Line on $\lambda/4$ mode.
A	28.5 mm.	9—14 cm.	24 cm.
B	43.5 mm.	11—19 cm.	29 cm.
C	58.5 mm.	12—24 cm.	35 cm.

The heater-cathode circuit may be tuned by means of a capacity bridge. The tuning is not critical for the longer wavelengths, but it is necessary for wavelengths around 10 cms., and must be used if maximum efficiency is required. However, a bridge fixed 7.2 cms. from the valve end of the cathode line will give reasonable operation over the range 8—12 cms.

Fig. 4 shows the power output obtainable over the wavelength range of 10—35 cms., with a constant input power of 10 watts, using the appropriate probe position and coupling, and with optimum grid bias. The optimum value of grid bias varies with the frequency, and the following table gives the approximate cathode bias resistance for various wavelengths.

Wavelength.	Cathode Bias Resistance.
30 cm.	300—350 ohms.
15 cm.	100 ohms.
12 cm. and less	Zero

The use of zero bias at a wavelength of 30 cm. may cause a reduction in efficiency of as much as 50%.

TYPE DET22

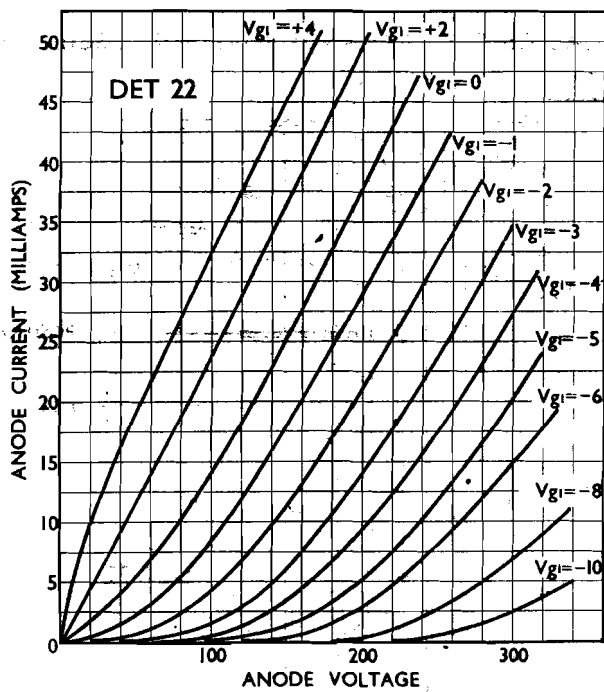

Fig. 3

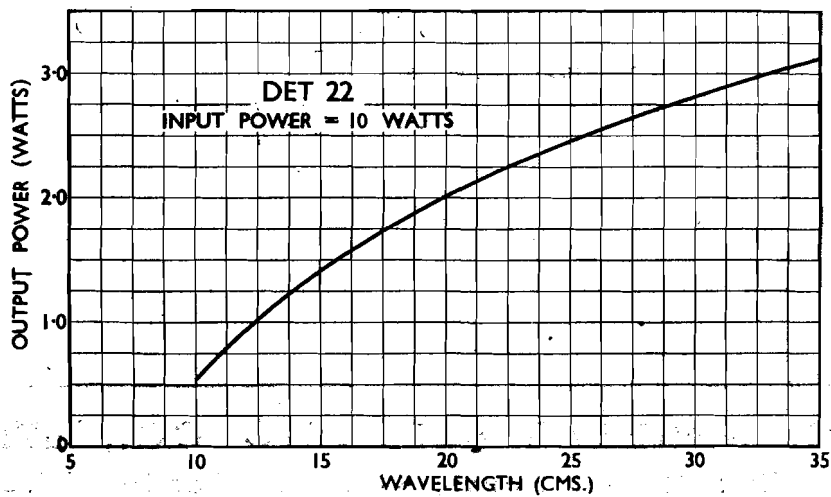

Fig. 4

TYPE DET22

TYPICAL CIRCUIT ARRANGEMENT FOR OSCILLATOR

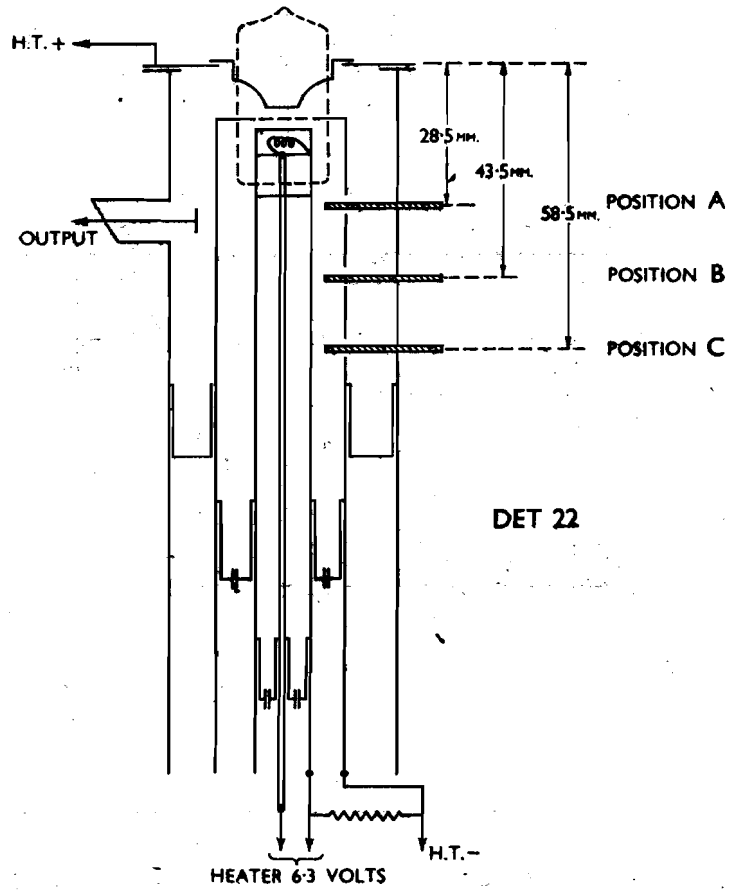

Fig. 5

THE GENERAL ELECTRIC CO., LTD.,
Head Office: Magnet House, Kingsway, London, W.C.2.

Printed in England. C.

Leaflet OV.176

September, 1947

SUPPLEMENTARY CONDITIONS OF SALE.

During the continuance of the abnormal conditions now prevailing, the following clauses shall apply to orders accepted by us :—

(1) PRICE.

- (a) All quotations and orders for the general range of merchandise in current demand are subject to prices ruling at date of despatch.
- (b) Except as provided in paragraph (a) above, all prices are based on the cost of material, labour, transport, and of conforming to statutory obligations ruling at the date of tender, and if between that date and the date on which the goods are despatched by us variations, either by rise or fall, shall occur in these costs then the price shall be amended to provide for these variations.

(2) DELIVERY.

Every endeavour will be made to despatch within the time stated, but no liability is accepted in regard thereto.

(3) GOODS HELD IN TRUST.

We expressly exclude any liability in respect of damage to or destruction of goods awaiting or under repair while in our possession arising out of war risks, and the goods will not be insured by us under the War Risks Insurance Act, 1939, Part II, or the War Damage Act, 1941.

In the event of goods being so damaged or destroyed we shall receive payment in full for all the costs incurred by us up to the time of the damage or destruction.

THE GENERAL ELECTRIC CO., LTD.

Head Office : Magnet House, Kingsway, London, W.C.2.