

INPUT IMPEDANCE OF FOLDED DIPOLE ANTENNAS

by

R. E. Beam
Northwestern University

P. Andris
Chicago Board of Education
Harrison High School

Abstract - This paper deals with the computation and measurement of the input impedance of folded-dipole antennas. A general expression for the input impedance is given in terms of the self- and mutual radiation impedances and the transmission-line impedance of the two conductors composing the folded dipole. Approximate values of the radiation impedances are computed using induced emf with sinusoidal current distributions and integral equation methods. Experimentally and theoretically determined curves representing the resistive and reactive components of the input impedance as functions of frequency are given for representative folded dipoles having equal- and unequal-size conductors. In some computations the effect of the gap capacitance at the feed point was taken into consideration.

I. Introduction

In recent years folded dipole antennas have been used extensively as receiving and transmitting antennas in such VHF and UHF applications as FM and TV broadcasting and radio communications.^{*1} In addition, folded unipole antennas, which are essentially half folded dipoles plus ground planes, have proved popular for radio communication applications such as police radio and other emergency communication services.² Hence, for these applications alone, the folded dipole is of considerable interest from the practical point of view.

The extensive use of folded dipoles and folded unipoles is attributable to their following characteristics

- (1) Their input impedances are considerably higher than those of simple dipoles and unipoles. Transmission lines of higher characteristic impedance than for simple dipoles or unipoles can be properly terminated; hence transmission losses can be reduced.
- (2) Their input impedances can be altered by changing the ratio of the diameters of the conductors forming the two sides of the folded dipole.
- (3) They have broad-band frequency characteristics comparable with those of simple dipoles and unipoles made from considerably larger conductors.
- (4) They can be connected directly to ground to provide lightning protection without affecting their performance characteristics.
- (5) They are easy to manufacture.

In addition to the interest in folded dipoles from the practical point of view, they are of considerable interest theoretically. The folded dipole is actually a rectangular loop antenna having a large ratio of length to width and carrying a nonuniform current. If the actual current distribution is

* See end of paper for numbered references.

known, the impedance of the antenna can be computed. However, the problem of determining the current distribution is a very difficult one to solve.

In solving for the current distribution and hence impedances of two identical coupled antennas, King and Harrison³ have resolved the applied voltages and the currents into symmetrical and antisymmetrical components following a suggestion made independently by Dr. A. H. Wing, and Mr. Roger Clapp. They utilized Hallén's⁴ integral equation method of determining the current distribution. Their computations were limited to spacings greater than 0.05 wavelengths. They showed that the current distributions on coupled parasitic antennas are different from those on the driven antennas; that the self-impedances of the antenna elements are functions of spacing when the spacing is small; and that the assumption of sinusoidally distributed currents is incorrect even in infinitely thin antennas for antenna lengths differing appreciably from a half wavelength. These results are contrary to the assumptions which are made in computations involving assumed sinusoidal current distributions following the procedures given by Carter⁵ and Brown.⁶

Tai⁷ and then King⁸ in August, 1952 have improved the method used by King and Harrison.³ Tai has shown that for two closely-coupled anti-symmetrically-driven antennas that the solution reduces to the conventional one obtained from transmission-line theory. Morita⁹ has checked experimentally the current and charge distributions predicted theoretically by Tai. The agreement was good.

These results for coupled antennas lead one to attempt an analysis of folded dipole antennas by treating them as coupled antennas. For symmetrical applied voltages, the current distributions and impedances should

be essentially the same as those given by King and Harrison and Tai for closely spaced coupled antennas. For antisymmetrical applied voltages, the current distribution and the input impedance should be the conventional ones for shorted open-wire lines obtained from transmission line theory. Folded dipoles formed from two identical conducting rods connected together at their ends have been given brief theoretical consideration by King and some of his associates at Cruft Laboratory. King gives the following expression for input impedance of a folded dipole for conditions near half-wave resonance:¹⁰

$$Z_{in} = 2(Z_{s1} + Z_{12})$$

where Z_{s1} is the self-impedance of the driven conductor, and Z_{12} is the mutual impedance between them. Both impedances being computed by methods for coupled antennas.³ For thin conductors and small spacings, Z_{s1} and Z_{12} do not differ greatly so then $Z_{in} \approx 4Z_{s1}$.

Van B. Roberts has considered the problem of determining the input impedance of folded dipoles formed from two conductors of different size. He utilizes an electrostatic approach to determine how the charge and hence currents divide between the two conductors. He has shown that the input impedance at resonance is approximately given by¹¹

$$Z_{in} = R \left\{ 1 + \frac{Z_{01}}{Z_{02}} \right\}^2$$

where R is the radiation resistance of the two conductors connected in parallel, Z_{01} is the characteristic impedance of a transmission line formed of

two conductors like the driven element and with the same center-to-center spacing as the actual antenna elements, and Z_{02} is similarly defined but for the parasitic element. Guertler by means of an essentially equivalent method of approach has obtained the same result as van B. Roberts but has considered folded dipoles of two and more elements,¹²

Schelkunoff and Friis have extended van B. Roberts' analysis and give the following formula for the input admittance of a folded dipole:¹³

$$Y_{in} = -\frac{1}{2} j Y_0 \cot \beta h + Y_p \left[1 + \frac{Z_{01}}{Z_{02}} \right]^{-2}$$

where Y_0 is the characteristic admittance of the conductors energized anti-symmetrically or in push-pull, and Y_p is the input admittance of the two conductors connected in parallel. This formula is similar to the formula developed in this paper and yields approximately the same results for many cases of practical interest.

This paper will include, in addition to the development of a formula for the input impedance of folded dipole antennas formed from conductors of unequal as well as equal size conductors, typical computed impedance curves, and the comparison of these computed curves with experimentally determined curves.

II. Derivation of Impedance Formula

A typical folded dipole made of conductors of unequal size is shown in Fig. 1(a). It is assumed that conductor 1, the driven conductor has a radius a_1 ; conductor 2 has a radius a_2 ; and that the conductors are spaced a distance

b between their axes. Since the system is linear, the principle of linear superposition may be applied to resolve the problem of determining the input impedance as seen by the generator V_1 into two less difficult problems.

If the folded dipole is pictured as two closely-coupled elements having self-impedances Z_{s1}^i and Z_{s2}^i and coupled by a mutual impedance Z_{12}^i , the following circuital equations can be written:

$$(1) \quad \begin{aligned} V_1 &= Z_{s1}^i I_1 + Z_{12}^i I_2 \\ 0 &= Z_{12}^i I_1 + Z_{s2}^i I_2 \end{aligned}$$

In writing these equations it is assumed that the generator whose voltage is V_1 is a point generator, that the currents I_1 and I_2 are the currents at the midpoints of elements 1 and 2, respectively, and that the impedances Z_{s1}^i , Z_{s2}^i and Z_{12}^i are based on the actual current distributions on the folded dipole. The input impedance determined by Eqs. (1) is given by

$$(2) \quad Z_{in} = Z_{s1}^i - (Z_{12}^i)^2 / Z_{s2}^i$$

If the impedances Z_{s1}^i , Z_{s2}^i and Z_{12}^i were known this expression could be used to determine the input impedance to the folded dipole. However, it is necessary to know the current distributions on conductors 1 and 2 in order to compute Z_{s1}^i , Z_{s2}^i and Z_{12}^i . These current distributions are not known and cannot easily be approximated. Hence, the currents at the midpoints of conductors 1 and 2 will be resolved into symmetrical and anti-symmetrical components; the distributions associated with the symmetrical and anti-symmetrical components of these reference currents will then be approximated; the input impedances associated with these components will

be computed; and then these impedances will be combined in such a way as to yield the input impedance resulting from the reference currents.

Figure 1(b) represents the problem of determining the input impedance of two closely coupled elements carrying equal "push-push" or symmetrical currents. Figure 1(c) similarly represents the problem of determining the input impedance of two closely-coupled elements carrying equal "push-pull" or antisymmetrical currents and constituting two transmission-line stubs with their "receiving ends" shorted and their "sending ends" connected in series.

By setting

$$(3) \quad \begin{aligned} I_1 &= I_s + I_a \\ I_2 &= I_s - I_a \end{aligned}$$

where I_s and I_a are symmetrical and antisymmetrical components of current, respectively, Eqs. (1) become

$$(4) \quad \begin{aligned} V_1 &= (Z'_{s1} + Z'_{12}) I_s + (Z'_{s1} - Z'_{12}) I_a, \\ 0 &= (Z'_{s2} + Z'_{12}) I_s + (Z'_{12} - Z'_{s2}) I_a. \end{aligned}$$

If we set,

$$(5) \quad \begin{aligned} (a) \quad V_{1s} &= (Z'_{s1} + Z'_{12}) I_s & (c) \quad V_{1a} &= (Z'_{s1} - Z'_{12}) I_a \\ (b) \quad V_{2s} &= (Z'_{s2} + Z'_{12}) I_s & (d) \quad V_{2a} &= (Z'_{s2} - Z'_{12}) I_a \end{aligned}$$

then Eqs. (4) are equivalent to

$$(6) \quad \begin{aligned} V_1 &= V_{1s} + V_{1a} \\ 0 &= V_{2s} - V_{2a} \end{aligned}$$

Since $V_{2s} - V_{2a}$ must equal zero, it follows by Eqs. (5b) and (5d) that

$$(7) \quad I_a/I_s = (Z'_{s2} + Z'_{12})/(Z'_{s2} - Z'_{12})$$

Equations (5) also imply that

$$(8) \quad (a) \quad \frac{V_{2s}}{V_{1s}} = \frac{Z'_{s2} + Z'_{12}}{Z'_{s1} + Z'_{12}} \equiv R \quad (b) \quad \frac{V_{1a}}{V_{2s}} = \frac{V_{1a}}{V_{2a}} = \frac{Z'_{s1} - Z'_{12}}{Z'_{s2} - Z'_{12}} \equiv \Delta$$

and
$$(c) \quad \frac{V_{1a}}{V_{1s}} = R\Delta$$

Since $V_1 = V_{1s} [1 + (V_{1a}/V_{1s})] = V_{1s} (1 + R\Delta)$, it follows by virtue of Eqs. (8) that

$$(9) \quad V_{1s} = V_1 / (1 + R\Delta) \quad V_{1a} = V_1 / [1 + (1/R\Delta)]$$

and

$$V_{2s} = V_{2a} = V_{1s} R$$

These equations show that for folded dipoles of unequal size conductors, the potential of conductor 2 is different in absolute value from that of conductor 1 when the conductors are carrying antisymmetrical currents.

If Eqs. (9) are substituted into either the first two or the last two of Eqs. (5), the following expressions for I_s and I_a are obtained:

$$(10) \quad I_s = V_1 / [(1 + R\Delta)(Z'_{s1} + Z'_{12})] = (V_1/2)(Z'_{s2} - Z'_{12})/D$$

$$I_a = V_1 / [(1 + (1/R\Delta))(Z'_{s1} - Z'_{12})] = (V_1/2)(Z'_{s2} + Z'_{12})/D$$

where $D = Z'_{s1} Z'_{s2} - Z'^2_{12}$

The second forms of these expressions indicate that I_s and I_a can also be obtained by computing the currents in conductor 1 when push-push and push-pull voltages of magnitude $V_1/2$ are applied in turn at the mid-points of conductors 1 and 2. However, if this is done, the magnitudes of the currents in conductor 2 will be different from those associated with the voltages, V_{1s} , V_{2s} , V_{1a} and V_{2a} unless the two conductors are of equal size. Hence, the currents in conductors 1 and 2 will have different magnitudes; therefore they cannot be computed using ordinary transmission-line theory. By applying the voltages V_{1a} and V_{2a} of Eqs. (9) to the conductors, the currents in the two conductors are equal in magnitude and opposite in sign as required by ordinary transmission-line theory.

From the viewpoint of ordinary transmission-line theory, the magnitude of the antisymmetrical current is given by

$$(11) \quad I_a = (V_{1a} + V_{2a})/2Z_{sc} = V_1 R(1 + \Delta) / [(1 + R\Delta)2Z_{sc}] \approx V_1/2Z_{sc}$$

where

$$(12) \quad Z_{sc} \approx j Z_0 \tan \beta h$$

is the input impedance of a shorted transmission line whose length is equal to the half-length of the folded dipole and whose conductors are identical in size and spacing with those of the folded dipole. The characteristic impedance Z_0 is computed using the following formula for unequal size conductors:

$$(13) \quad Z_0 = 138 \log_{10} \left[\left(\frac{b}{2a_1} \right) + \sqrt{\left(\frac{b}{2a_1} \right)^2 - 1} \right] \left[\left(\frac{b}{2a_2} \right) + \sqrt{\left(\frac{b}{2a_2} \right)^2 - 1} \right]$$

A satisfactory approximate expression for the symmetrical or push-push current is much more difficult to find. If symmetrical voltages, each of magnitude $V_1/2$ are applied to equal size conductors, Eq. (10) with $Z_{s1}^i = Z_{s2}^i$ could be used to compute I_s if the impedances Z_{s1}^i and Z_{s2}^i were known. However, for this case, values of $Z_{s1}^i = Z_{s1}$ and $Z_{12}^i = Z_{12}$, where Z_{s1} and Z_{12} are computed by the method used by King and Harrison³ and by Tai⁷ in their analyses of coupled antennas, could be used. Also, as a less exact approximation Z_{s1} and Z_{12} could be computed using sinusoidal approximations for the current distributions.^{5,6} Hence, one is led to utilize the latter method in computing Z_{s1} , Z_{s2} and Z_{12} for the case of unequal size conductors and to use the results of these computations in place of Z_{s1}^i , Z_{s2}^i , and Z_{12}^i to compute I_s . Also, one is led to use values of self- and mutual impedance obtained by various approximate methods which are strictly applicable only under conditions that proximity effects on impedances are negligible.

Now that approximate methods of computing I_s and I_a are available, the input impedance of the folded dipole can be computed utilizing the formula

$$(14) \quad Z_{in} = V_1 / (I_s + I_a)$$

If Eqs. (6a) and (7) and approximate expressions for the various impedances are properly utilized, Eq. (14) yields for $I_a = 0$

$$(15) \quad Z_{in} = (Z_{s1} + Z_{12})' + (Z_{s2} + Z_{12}) \Delta = 2(Z_{s1} + Z_{12} \Delta)$$

where Δ is defined in Eq. (8b). For equal size conductors $\Delta = 1$ so that

$$(16) \quad Z_{in} = 2(Z_{s1} + Z_{12})$$

in agreement with the results of a previous analysis.¹⁰ For $I_a \neq 0$,

$$(17) \quad Z_{in} = 2 Z_{sc}' Z_{1A}' / (Z_{1A}' + Z_{sc}')$$

where

$$(18) \quad Z_{1A}' = (Z_{s1} + Z_{12} \Delta)$$

and

$$(19) \quad Z_{sc}' = Z_{sc} (1 + R \Delta) / R(1 + \Delta) \approx Z_{sc}$$

III. Impedance Formula for Sinusoidal Currents

Self- and mutual impedances of linear antenna elements are usually computed by methods based on the assumption of sinusoidal current distributions along the axes of the elements. This assumption leads to the following formulas for the components of the mutual impedance:¹⁴

$$\begin{aligned}
 R_{12} = & (1/\sin^2 \beta h) \left\{ 60 \left[2\text{Ci}\beta b - \text{Ci}\beta(r_{04} + h) - \text{Ci}\beta(r_{04} - h) \right] \right. \\
 & + 30 \left[2\text{Ci}\beta b - 2\text{Ci}\beta(r_{04} + h) - 2\text{Ci}\beta(r_{04} - h) \right. \\
 (20) \quad & \left. \left. + \text{Ci}\beta(r_{14} + 2h) + \text{Ci}\beta(r_{14} - 2h) \right] \cos 2\beta h \right. \\
 & \left. + 30 \left[2\text{Si}\beta(r_{04} - h) - 2\text{Si}\beta(r_{04} + h) + \text{Si}\beta(r_{14} + 2h) \right. \right. \\
 & \left. \left. - \text{Si}\beta(r_{14} - 2h) \right] \sin 2\beta h \right\}
 \end{aligned}$$

$$\begin{aligned}
 X_{12} = & (1/\sin^2 \beta h) \left\{ 60 \left[\text{Si}\beta(r_{04} + h) + \text{Si}\beta(r_{04} - h) - 2\text{Si}\beta b \right] \right. \\
 & + 30 \left[2\text{Si}\beta(r_{04} + h) + 2\text{Si}\beta(r_{04} - h) - 2\text{Si}\beta b \right. \\
 (21) \quad & \left. \left. - \text{Si}\beta(r_{14} + 2h) - \text{Si}\beta(r_{14} - 2h) \right] \cos 2\beta h \right. \\
 & \left. + 30 \left[2\text{Ci}\beta(r_{04} - h) - 2\text{Ci}\beta(r_{04} + h) + \text{Ci}\beta(r_{14} + 2h) \right. \right. \\
 & \left. \left. - \text{Ci}\beta(r_{14} - 2h) \right] \sin 2\beta h \right\}
 \end{aligned}$$

In these formulas

$$\text{Ciu} = \int_{\infty}^u \frac{\cos x}{x} dx$$

and

$$\text{Si } u = \int_0^u \frac{\sin x}{x} dx$$

are the conventional cosine and sine integrals.

The limiting forms of Eqs. (20) and (21) for small spacings $b = a$, the radius of the conductor, yield the following expressions for the self-impedance of the conductor:

$$(22) \quad R_{11} = (1/\sin^2 \beta h) \left\{ 60(C + \ln 2\beta h - \text{Ci}2\beta h) + 30(\text{Si}4\beta h - 2\text{Si}2\beta h) \sin 2\beta h \right. \\ \left. + 30(C + \ln \beta h - 2\text{Ci}2\beta h + \text{Ci}4\beta h) \cos 2\beta h \right\}$$

$$(23) \quad X_{11} = (1/\sin^2 \beta h) \left\{ 60 \text{Si}2\beta h + 30(2\text{Si}2\beta h - \text{Si}4\beta h) \cos 2\beta h \right. \\ \left. - 30(\ln \frac{h\lambda}{a^2} - C - \ln 2\pi - \text{Ci}4\beta h + 2\text{Ci}2\beta h) \sin 2\beta h \right\}$$

In these expressions $C \approx 0.5772$ is Euler's constant.

The fact that $Z_{11} = R_{11} + jX_{11}$ is a limiting form of $Z_{12} = R_{12} + jX_{12}$ for small spacings suggest that Δ as defined in Eq. (8b) be computed using the formulas for R_{11} and X_{11} in place of those for R_{12} and X_{12} , respectively, but with the spacing b replacing the radius a . If this is done, Δ simplifies to the following form:

$$(24) \quad \Delta = \log(b/a_1) / \log(b/a_2) = Z_{01} / Z_{02}$$

where Z_{01} and Z_{02} are characteristic impedances as previously defined. Also by Eq. (8b), the ratio of the potential of conductor 1 to that of conductor 2 when they carry antisymmetrical currents is equal to Δ .

Utilizing the approximation of Eq. (25), the input impedance as given for $I_a = 0$ by Eq. (15) simplifies to

$$(25) \quad Z_{in} = 2 \left[Z_{s1} + Z_{12} (Z_{01}/Z_{02}) \right]$$

In addition, if Z_{s1} and Z_{12} are pure resistances, this expression becomes

$$(26) \quad R_{in} = 2 \left[R_{s1} + R_{12} (Z_{01}/Z_{02}) \right]$$

Since R_{s1} and R_{12} are approximately equal in magnitude, the last equation can be further simplified to give

$$(27) \quad R_{in} = 2R_{s1} \left[1 + (Z_{01}/Z_{02}) \right]$$

This equation is a useful design equation. It should be noted that $R_{in} \approx 4R_{s1}$ for equal size conductors; that $R_{in} < 4R_{s1}$, if $Z_{01} < Z_{02}$; and that $R_{in} > 4R_{s1}$ if $Z_{01} > Z_{02}$.

In the introduction to this paper the equivalent of the following expression for the input admittance of a folded dipole was given:

$$Y_{in} = \frac{1}{2} Y_{sc} + Y_p (1 + \Delta)^{-2}$$

where $\Delta = Z_{01}/Z_{02}$. According to the analysis of this paper (See Eq. (17))

$$Y_{in} = \frac{1}{2} (Y_{sc} + Y'_{1A})$$

Hence the two results are in agreement if

$$\frac{1}{2} Y_{1A} = Y_p (1 + \Delta)^{-2}$$

The admittance Y_p of the two conductors in parallel can be shown by solving the circuit equations for equal applied voltages and sinusoidal current distributions to be related to Y'_{1A} as follows:

$$(29) \quad Y_p = \frac{I_{1s} + I_{2s}}{V_1} = (I_{1s}/V_1) \left[1 + (I_{2s}/I_{1s}) \right] = (Y_{1A}) \left[1 + \Delta \right]$$

where I_{1s} and I_{2s} are the currents in conductors 1 and 2, respectively, when excited in parallel with a voltage V_1 . Therefore the condition for agreement of the two results simplifies to

$$(30) \quad \Delta = 1$$

This condition is satisfied only if the two conductors forming the folded dipole are of equal size.

IV. Computed and Experimental Results

Measurements and computations of the input impedance of the two folded dipoles shown in Fig. 2 were made. Both antennas were made of copper tubing. The first antenna was made of 7/8-inch O.D. copper tubing; the second, of 7/8-inch O.D. and 3/8-inch O.D. copper tubing, the fed element having the smaller diameter. The elements were 2.8 feet long and had center-to-center spacings of three inches.

Impedance measurements were made using the arrangement shown in Fig. 3. Since a slotted line was used for impedance measurements it was necessary to use a balance-to-unbalance transformer (balun) between the balanced folded dipole and the unbalanced slotted line. An experimental method was used to determine the frequency at which the balun was a half wavelength long before the antenna was connected. Corrections were made in the measured values of impedance for the effect of the balun and the associated coaxial cable.¹⁵

Figure 4 shows curves of the input resistance and reactance of the folded dipole of Fig. 2(a) as functions of βh , the half-length of the dipole in radian measure. It should be noted that there are two frequencies of anti-resonance and one frequency of series resonance in the range plotted.

Figure 5 shows approximately equivalent circuits for frequencies near the resonant and anti-resonant frequencies. For the lower frequency of anti-resonance the anti-symmetrical or "transmission-line" currents are associated with an inductive reactance since shorted lines which are less than a quarter-wavelength long are inductive. For the higher frequency of anti-resonance, the shorted lines are capacitive since the shorted lines which are more than a quarter-wavelength but less than a half-wavelength long are capacitive. For the lower frequency of anti-resonance the symmetrical or "antenna" currents have associated with them an impedance which is capacitive since a simple linear antenna element has a capacitive impedance for half-lengths appreciably shorter than a quarter wavelength. For the higher frequency of anti-resonance, an antenna element has an inductive impedance. Series resonance occurs at a frequency between the two anti-resonant frequencies. The impedance associated with the transmission line currents is so high as to be almost negligible for frequencies at or near the frequency of series resonance of the folded dipole. Series resonance of the antenna having equal size occurs for a frequency of 160 megacycles per second. Since the antenna elements are 2.8-feet or 85.3-cm long, series resonance occurs for this antenna when its length is 91.5 percent of a half wavelength. At the frequency of series resonance the impedance of this folded dipole is 263 ohms. By

Eq. (27) with $R_{s1} = 73.2$ ohms the impedance would be 292.8 ohms.

Figures 6 and 7 give curves representing computed and measured values of the input resistance and input reactance of the folded dipole of equal size elements. The computed curves of Fig. 6 were based on an assumed sinusoidal distribution of currents on both elements. Those of Fig. 7 were based on a distribution of current determined by Tai's method for coupled elements.⁷ Both figures contain curves which show the effect of a shunt capacitance of 0.65 mmf across the gap in the excited element. This value of gap capacitance was based on low-frequency measurements of the impedance of a center-fed element like that of Fig. 2(a). The agreement between measured and computed values is reasonably good for frequencies at or near series resonance. Overall agreement in the frequency range for which computations were made was better when gap capacitance was taken into account. However, the inclusion of a gap capacitance tended to make the agreement in the resistance values poorer for the lower frequencies.

Figure 8 represents the input resistance and input reactance of the folded dipole of unequal size elements (see Fig. 2) as functions of electrical length. One pair of computed curves is based on a sinusoidal current distribution. Since no adequate theory of coupled antennas of unequal size conductors is currently available, the other is based on sinusoidal distributions for the mutual impedance, but on the distribution determined by the King-Middleton method, for self-impedances.¹⁶ The agreement between measured and computed values is fair. It should be noted that series resonance occurs for antenna lengths of about 92.5 percent of a

half wavelength and that the resistance at resonance is larger than that for equal size elements. However, the measured value of resistance is appreciably larger than the computed value. The approximate equation (27) with $R_{s1} = 73.2$ ohms yields a resistance of 435 ohms. This value is about 50 percent larger than that for a folded dipole with equal size elements. If the experimental values are compared for the two antennas it will be found that Eq. (27) gives an approximation to the percent increase in resistance resulting from making the fed element half as large as the other element.

V. Conclusions

The results of this investigation show that the input impedance of a folded dipole can be computed with fair accuracy using the following equations (element 1, the driven element):

$$Z_{in} = 2 Z_{sc}^i Z_{1A}^i / (Z_{1A}^i + Z_{sc}^i)$$

$$Z_{1A}^i = (Z_{s1} + Z_{12} \Delta)$$

$$\Delta = (Z_{s1} - Z_{12}) / (Z_{s2} - Z_{12})$$

$$Z_{sc}^i = Z_{sc} (1 + R \Delta) / R (1 + \Delta)$$

$$Z_{sc} \approx j Z_0 \tan \beta h$$

$$R = (Z_{s2} + Z_{12}) / (Z_{s1} + Z_{12})$$

$$Z_0 = 138 \log_{10} \left[\left(\frac{b}{2a_1} + \sqrt{\left(\frac{b}{2a_1} \right)^2 - 1} \right) \left(\frac{b}{2a_2} + \sqrt{\left(\frac{b}{2a_2} \right)^2 - 1} \right) \right]$$

In these equations the impedances Z_{s1} , Z_{s2} and Z_{12} should be computed utilizing a method for closely coupled antennas such as that discussed by Tai for the special case of equal size conductors.⁷ No results of an adequate theory of coupled or unequal size conductors are currently available. However, Z_{s1} , Z_{s2} and Z_{12} can also be approximated utilizing Eqs. (20) to (23), for which case Δ is given by Eq. (24).

The values of input impedance determined by use of the latter approximations are somewhat high as would be expected. At series resonance, the folded dipole formed from equal size conductors yielded an input resistance of about 263 ohms, experimentally, but a value of 293.8 ohms, when computations utilizing Eqs. (20) to (24) are made, - a fairly large error. Nevertheless, the theory does give a good approximation to the percent change in input impedance at series resonance as the ratio of diameters of the conductors is varied from a ratio of unity.

For design purposes, if an experimental value of the input resistance is known for one ratio of conductor diameters, and the conductor spacing is small then the following simple expression can be used to approximate the resistance for some other ratio of conductor diameters or some other conductor spacing:

$$\frac{R_{in}}{R_{in}'} = \frac{1 + \Delta}{1 + \Delta'}$$

where Δ now equals the ratio of characteristic impedances as given by $\Delta = Z_{01} / Z_{02} = \log(b/a_1) / \log(b/a_2)$. The value of Δ' is given by the same expression as Δ if the appropriate radii and spacing are used.

Series resonance can be expected to exist for conductor lengths

of the order of 90 to 95 percent of a half wavelength depending upon the size of the conductors. Small diameter conductors require the longer lengths. Hence, to design a folded dipole to match a given line, the length of the conductors should be chosen for series resonance at the desired frequency; the ratio of conductor diameters, for impedance match; and the conductor sizes and spacings, to meet the broad-band requirements.

Figure Captions

- Fig. 1 - Folded dipole antenna from the viewpoint of the Superposition Theorem and "push-push" and "push-pull" currents.
- Fig. 2 - Physical dimensions of the antennas on which data is given.
- Fig. 3 - Impedance measuring apparatus.
- Fig. 4 - Measured values of the input impedance of the antenna of equal size conductors.
- Fig. 5 - Approximate equivalent circuits representing electrical behavior of a folded dipole for different frequency ranges.
- Fig. 6 - Measured values of input impedance of the antenna of equal size conductors compared with computed values based on sinusoidal current distributions. The gap capacitance was 0.65 mmf.
- Fig. 7 - Measured and computed values of input impedance of the antenna of equal size conductors compared with computed values based on current distributions determined by Tai's theory of coupled antennas.
- Fig. 8 - Measured values of input impedance of the antenna of unequal size conductors compared with computed values based on self-impedances determined by the King-Middleton theory of cylindrical antennas and mutual impedances determined by sinusoidal current distributions.

References

1. P. S. Carter, "Simple Television Antennas," RCA Review, vol. 4, p. 168; October, 1939.
2. J. S. Brown, "A Folded Unipole Antenna for Emergency Communications," Communications, vol. 26, pp. 18-20; November, 1946.
3. R. King and C. W. Harrison, Jr., "Mutual and Self-Impedance for Coupled Antennas," J. Appl. Phys., vol. 15, pp. 481-495; June, 1944.
4. E. Hallen, "Theoretical Investigations into the Transmitting and Receiving Qualities of Antennas," Nova Acta Uppsala, vol. 77, pp. 1-44; November, 1938.
5. P. S. Carter, "Circuit Relations in Radiating Systems and Applications to Antenna Problems," Proc. I.R.E., vol. 20, p. 1004; June, 1932.
6. G. H. Brown, "Directional Antennas," Proc. I.R.E., vol. 25, p. 78; January, 1937.
7. C. T. Tai, "Coupled Antennas," Proc. I.R.E., vol. 36, pp. 487-500; April, 1948.
8. R. King, "Self- and Mutual Impedances of Parallel Identical Antennas," Proc. I.R.E., vol. 40, pp. 981-988.
9. T. Morita and C. Faflick, "Measurement of Current Distribution along Coupled Antennas and Folded Dipoles," Proc. I.R.E., vol. 39, pp. 1561-1565; December, 1951.
10. R. King, H. R. Mimno, A. H. Wing, "Transmission Lines Antennas and Wave Guides," McGraw-Hill Book Company, Inc., New York, N. Y., pp. 224-26; 1945.
11. W. van B. Roberts, "Input Impedance of a Folded Dipole," RCA Rev., vol. 8, p. 289; June, 1947.
12. R. Guertler, "Impedance Transformation in Folded Dipoles," Proc. I.R.E., vol. 38, pp. 1042-47; September, 1950.
13. S. A. Schelkunoff and H. T. Friis, "Antennas: Theory and Practice," John Wiley and Sons, Inc., New York, N.Y., pp. 339-41 and problem 12.12-1, p. 401; 1952.
14. S. A. Schelkunoff, "Electromagnetic Waves," D. Van Nostrand Co., New York, N.Y., pp. 372-73; 1943.
15. F. E. Butterfield, "Coaxial Impedance Matching Links," Tele-Tech, p. 29, December, 1949.
16. R. King and D. Middleton, "The Cylindrical Antenna: Current and Impedance," Quar. Appl. Math., vol. III, No. 4, pp. 302-335; January, 1946.

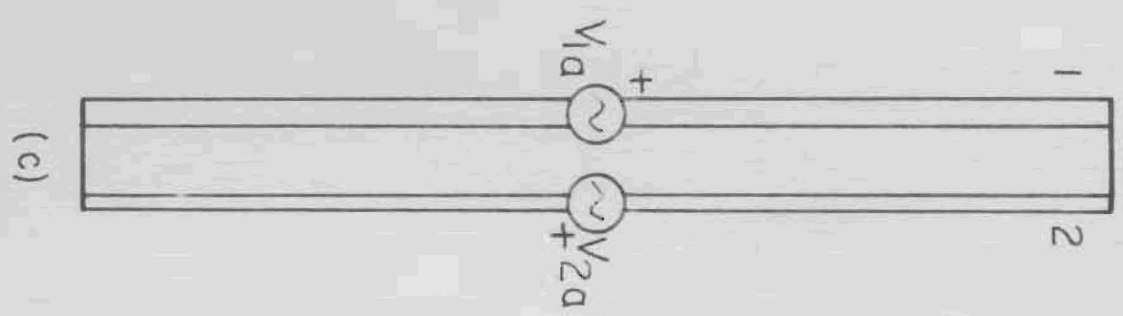
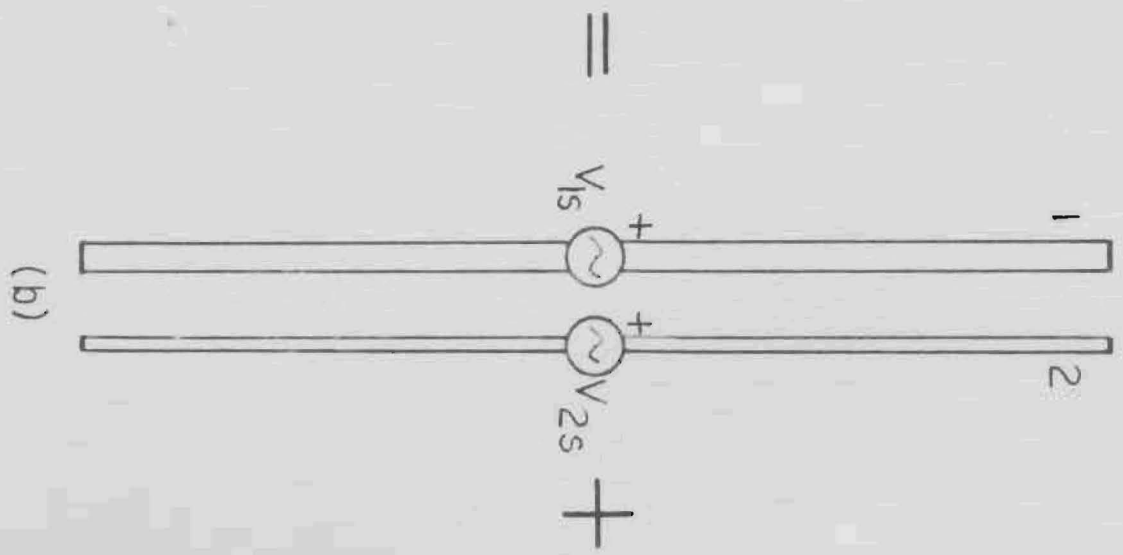
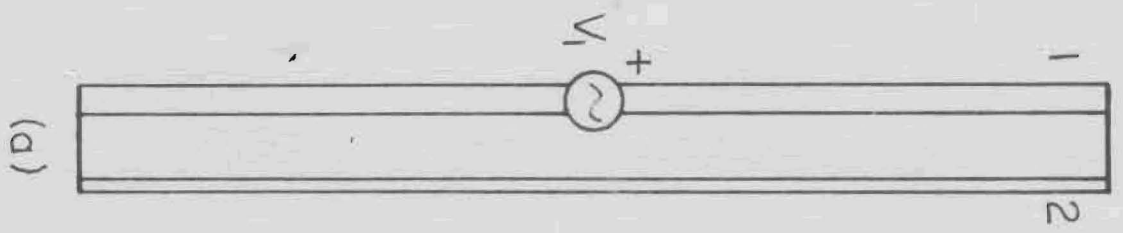

=

+

(a)

(b)

(c)

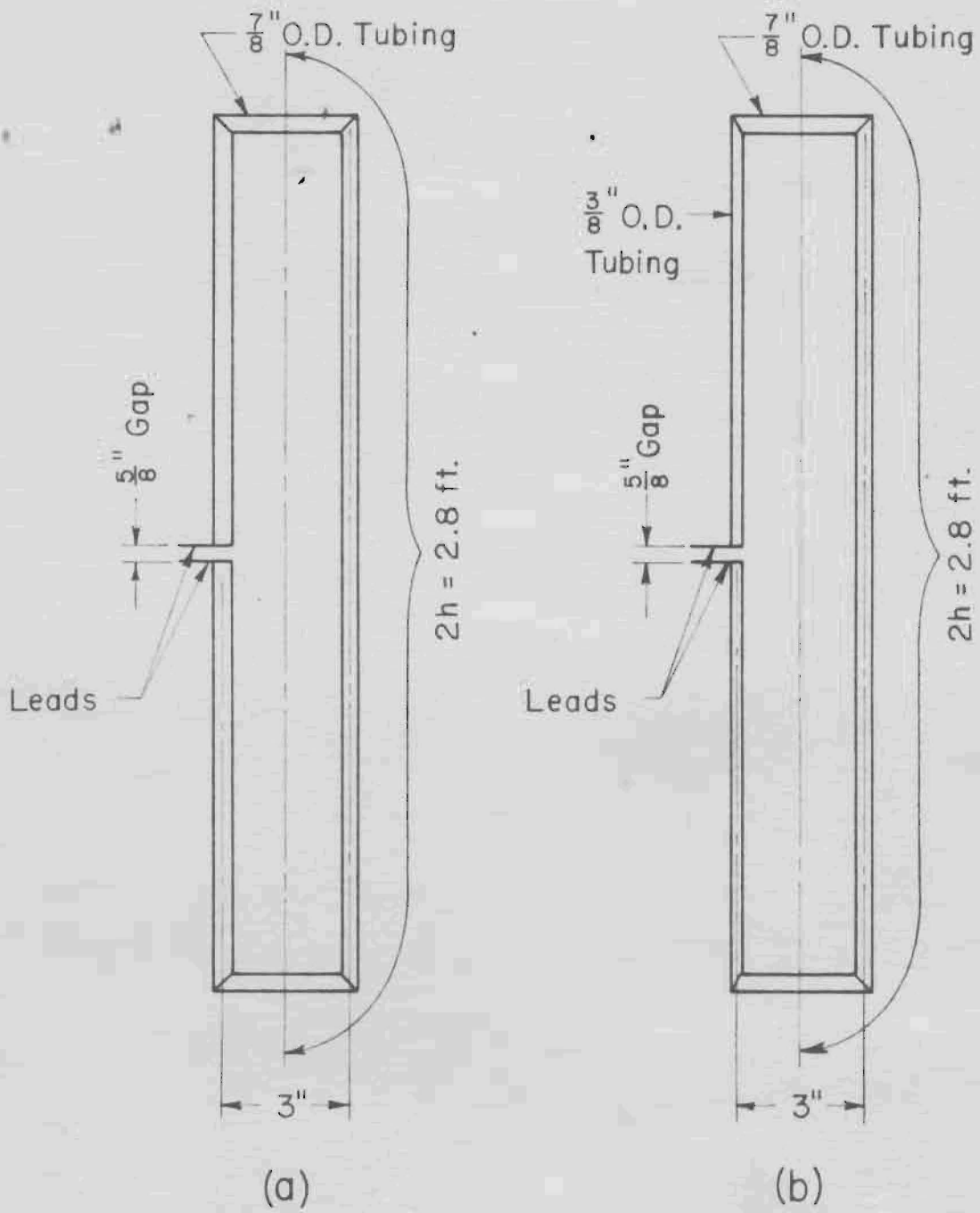

Fig

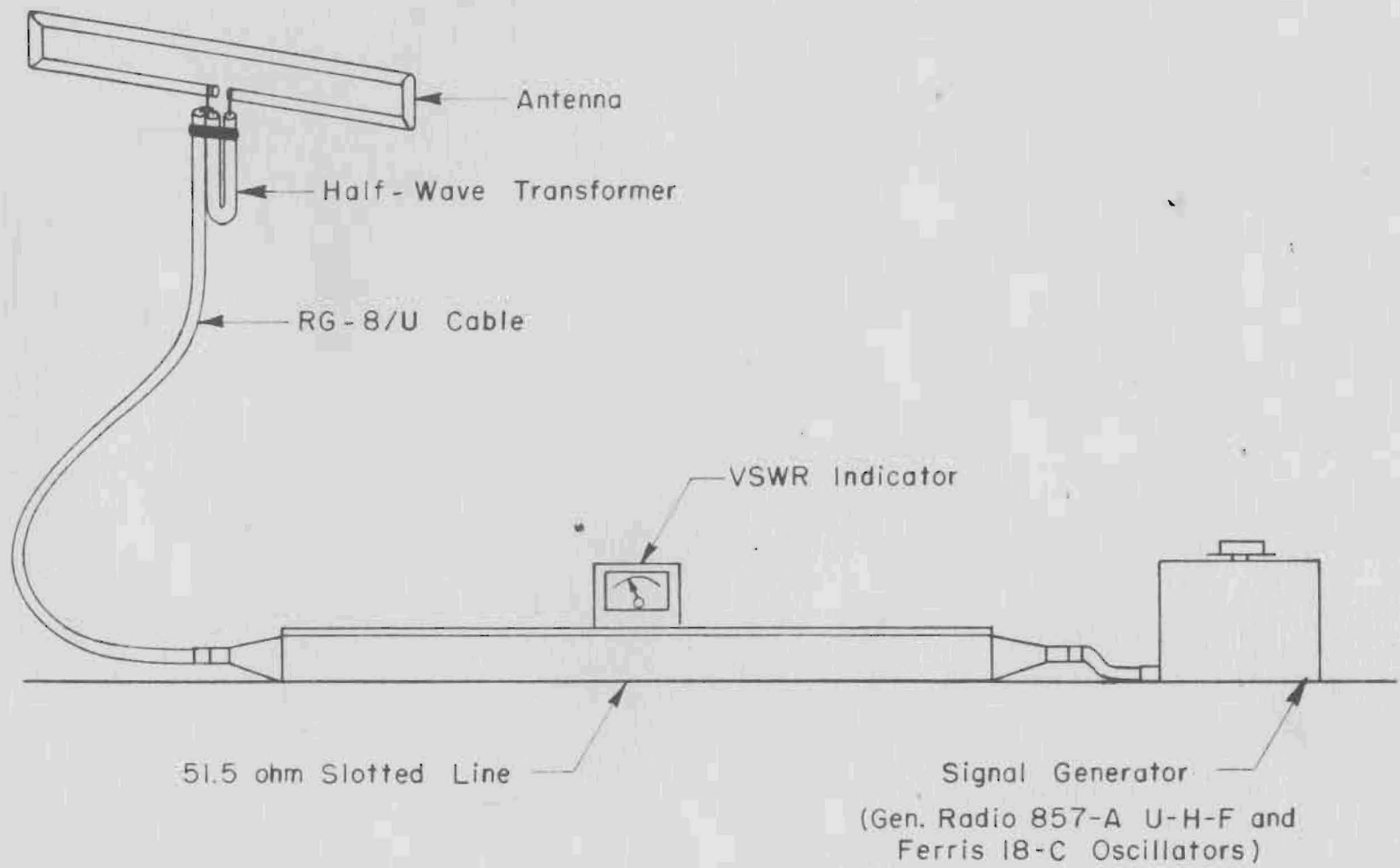

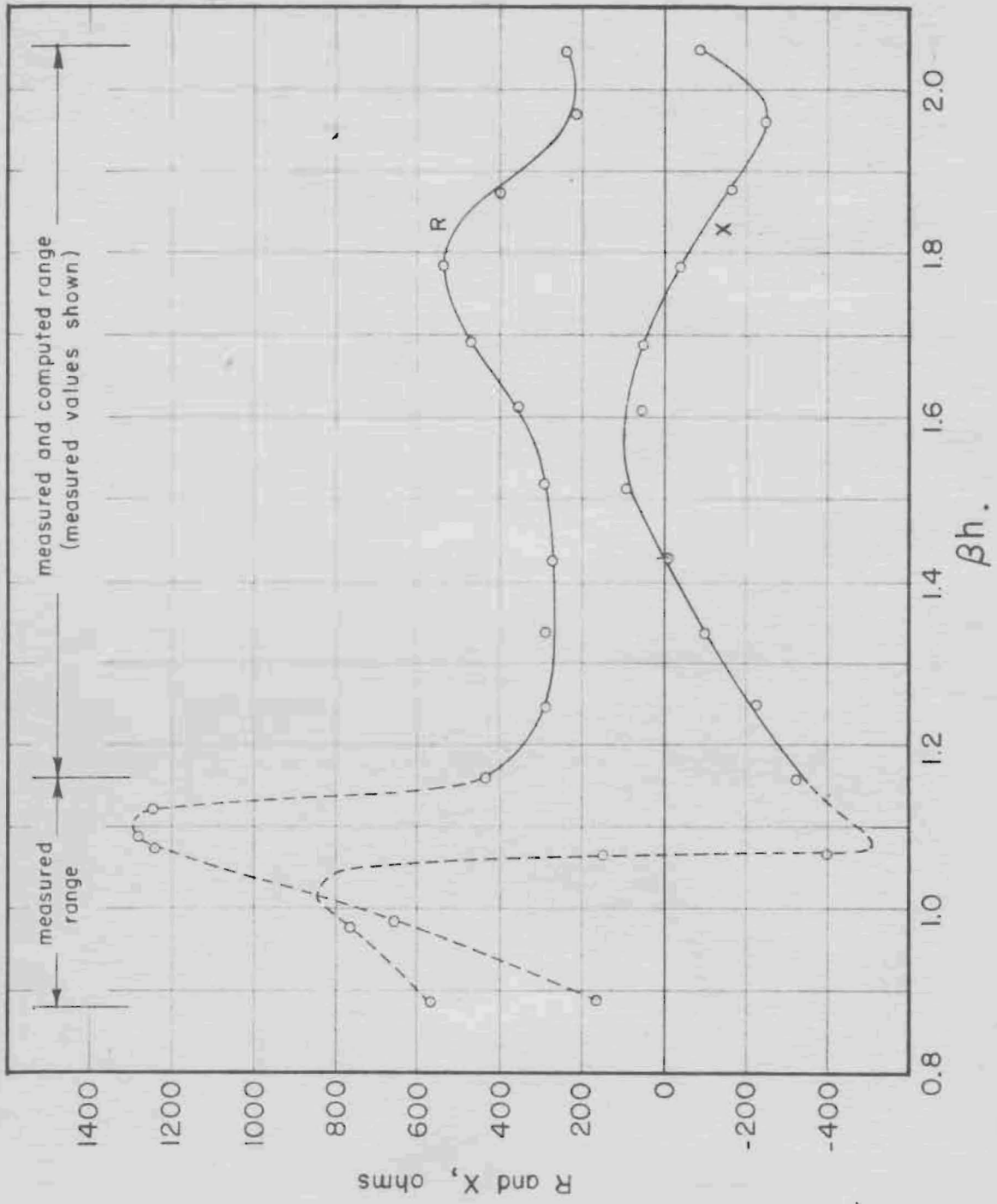

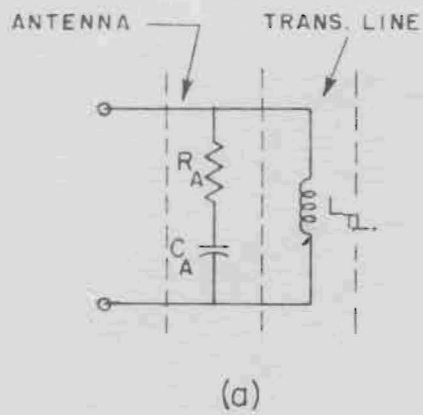

$$\beta h < \frac{\pi}{2}$$

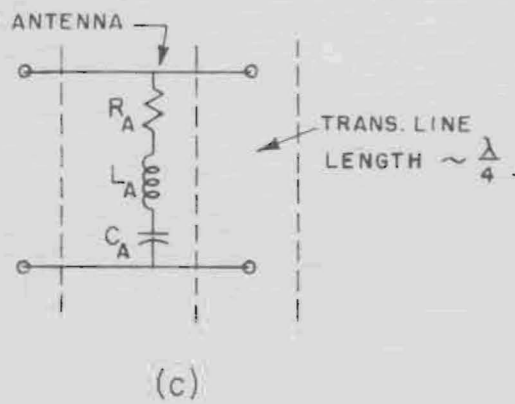
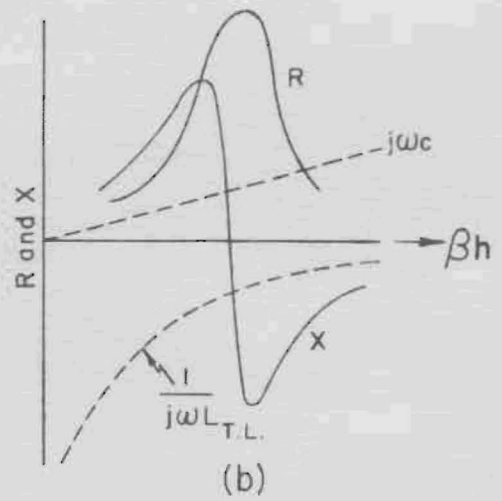

$$\beta h \sim \frac{\pi}{2}$$

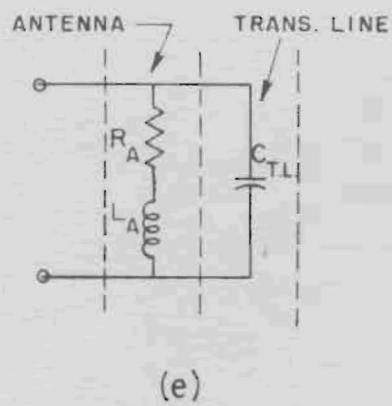
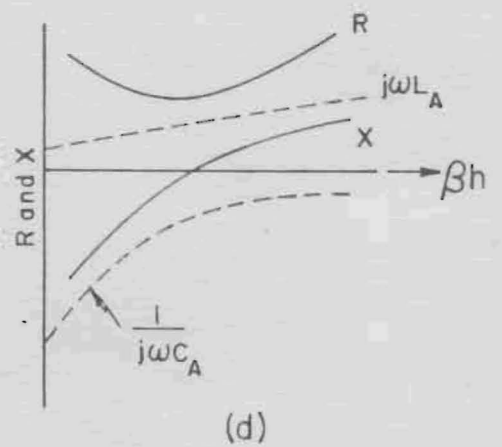

$$\beta h > \frac{\pi}{2}$$

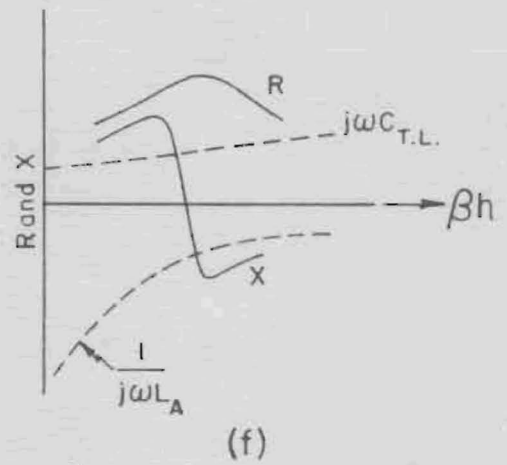

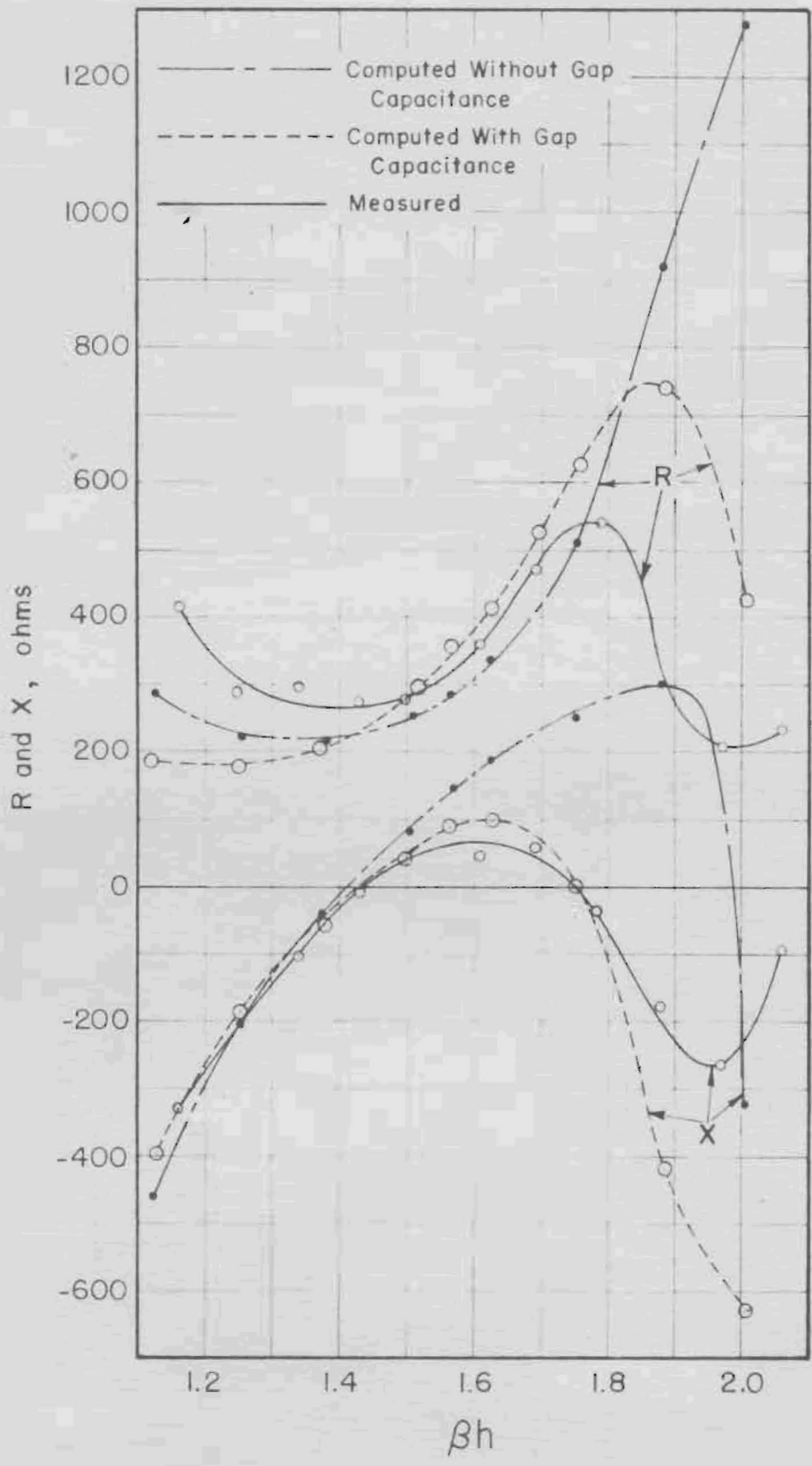

Carters

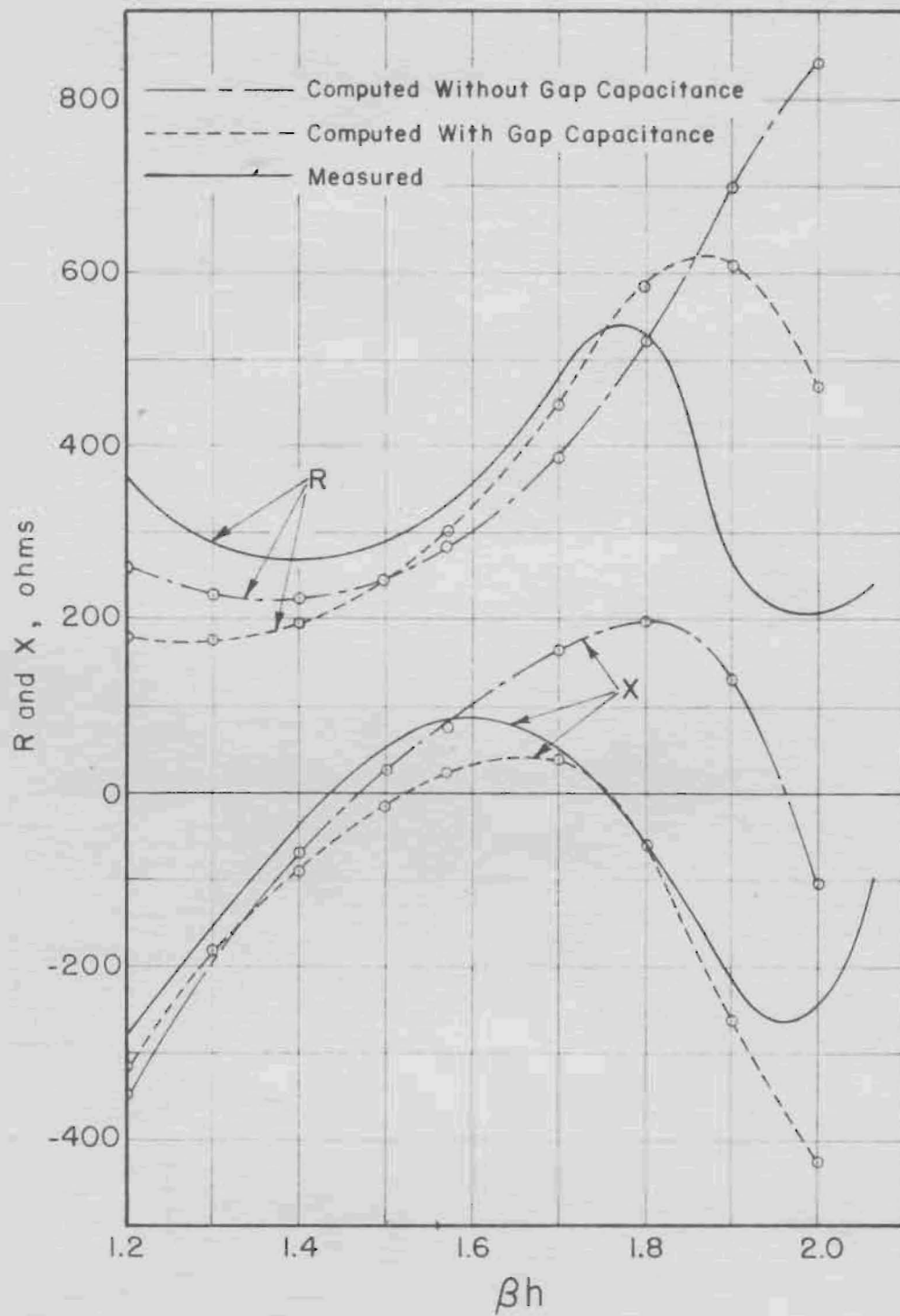

100

