

MHB:NMD

16th November, 1961.

Tasmanian Metalware Ltd.,
153 Campbell Street,
HOBART.

Dear Sirs,

The sample metal box made for Mr. Reber last month has been tested and found satisfactory with the following alterations.

1. Increase lip at bottom from $\frac{1}{4}$ " to $\frac{1}{2}$ " and size of cover appropriately.
2. Close corner slots on back of cover at top by folding top lip over sides or by soldered triangular patch.
3. Holes on top to be drilled $\frac{15}{32}$ " dia. by suitable bit to produce clean edge. Bit provided by C.S.I.R.O.
4. Drill with similar bit a $\frac{1}{4}$ " hole in back centre at 1" above bottom.
5. Fasten on back by two rivets spaced 10" apart and 1" down from top, a bracket supplied by C.S.I.R.O.,
6. One $\frac{5}{32}$ " dia. hole in centre of each end.
7. Four $\frac{5}{32}$ " holes at corners of 3" square centred on $3\frac{1}{2}$ " holes in bottom. Make accurate drilling template to fit into $3\frac{1}{2}$ " holes to insure uniformity.

Please quote price and availability upon 100 boxes as described above. The sample will be returned upon request.

Yours faithfully,

M.H. Bennett
Clerical Officer.

MHB:NMD

17th November, 1961.

H.M. Bamford & Sons Ltd.,
228 Murray Street,
HOBART.

Attention: Mr. Connor.

Dear Sirs,

This letter confirms a telephone conversation wherein you quoted to Dr. Reber as follows:-

200 pcs. black Insulite 4" x 4" x $\frac{1}{8}$ " @ 1/1d. each.

Please expedite the delivery of the above. The invoice is to be directed to this office for his account.

Yours faithfully,

M.H. Bennett
Clerical Officer.

BAKELITE PLATES

$\frac{1}{8}$ THICK

A

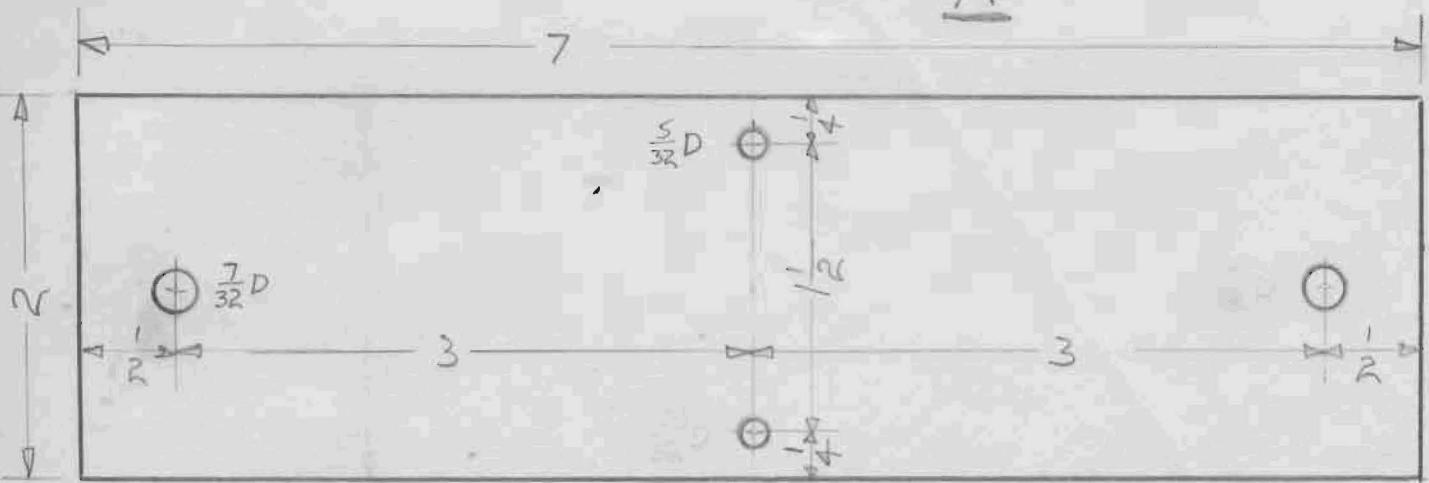

B

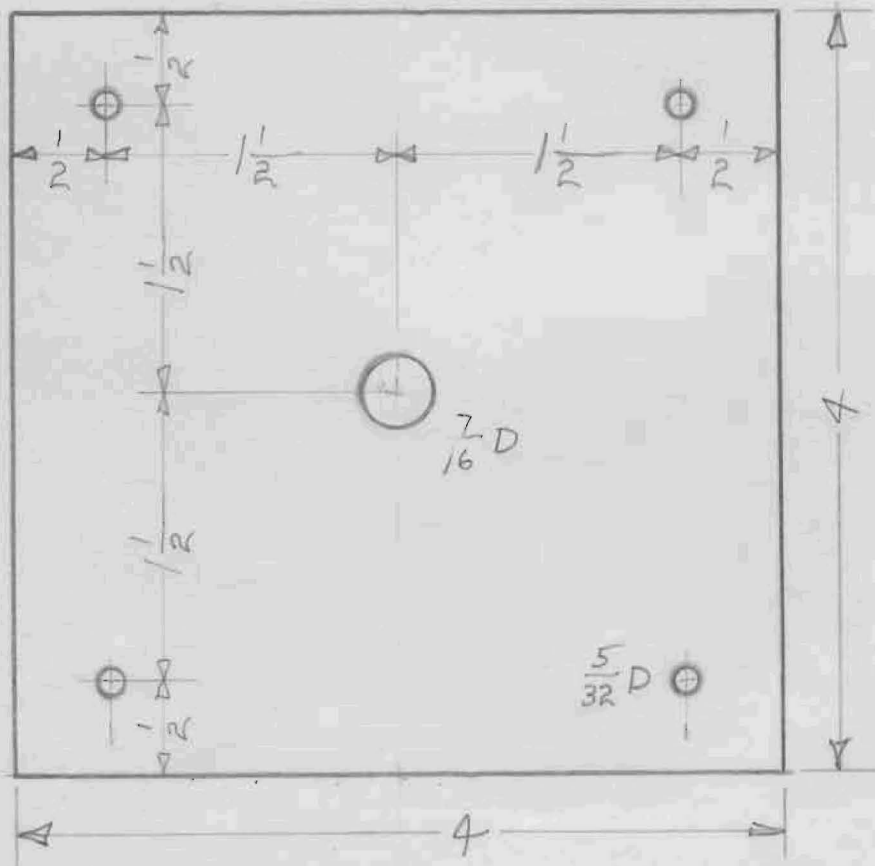

REGISTERED OFFICE:
141 COLLINS STREET
HOBART

SPOUTING . RIDGE CAPPING . DOWNPIPE . COPPER PIPE

Tas Metalware Products Pty. Ltd.

SHEETMETAL GOODS MANUFACTURER

Everware Hot Water Units

153-155 CAMPBELL STREET, HOBART, Tas. Telephone: 2 5044

The Clerical Officer,

22-11-61.

Commonwealth Scientific & Industrial Research Org.,

Tasmanian Regional Laboratory,
Howell Ave. Hobart.

Dear Sir,

We are pleased to submit the following
quotation for metal boxes with alternatives as requested.

£1-15-0 each.

Boxes will be available one week from the date
the sample is returned.

Yours Sincerely
D Webb

LAYOUT

$\frac{1}{4}$ SIZE

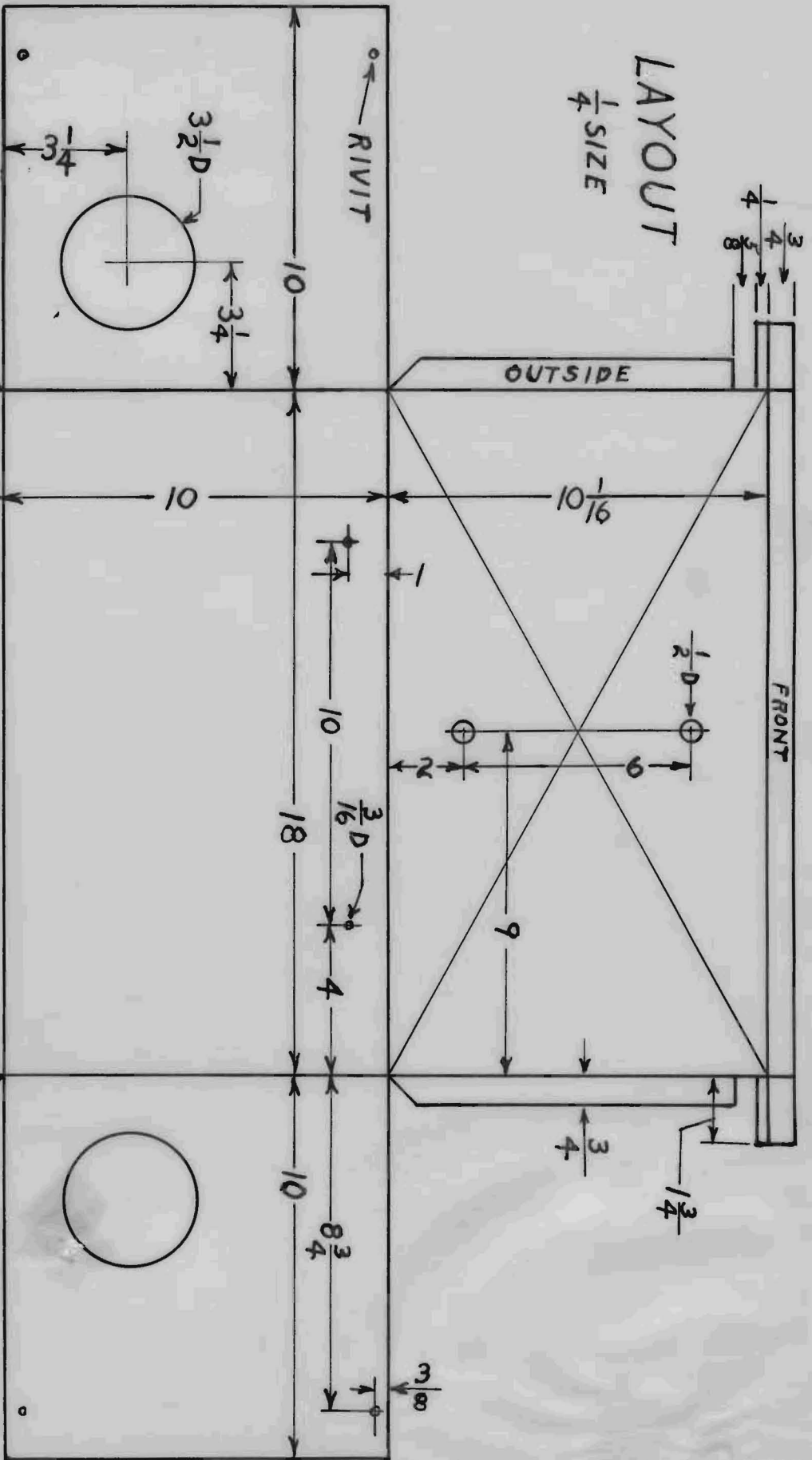

- 2 HOLES $\frac{3}{16} D$
- 2 " $\frac{1}{2} D$
- 2 " $3 \frac{1}{2} D$
- 4 RIVITS

INSIDE

OUTSIDE

FRONT

26 GA. GALV.

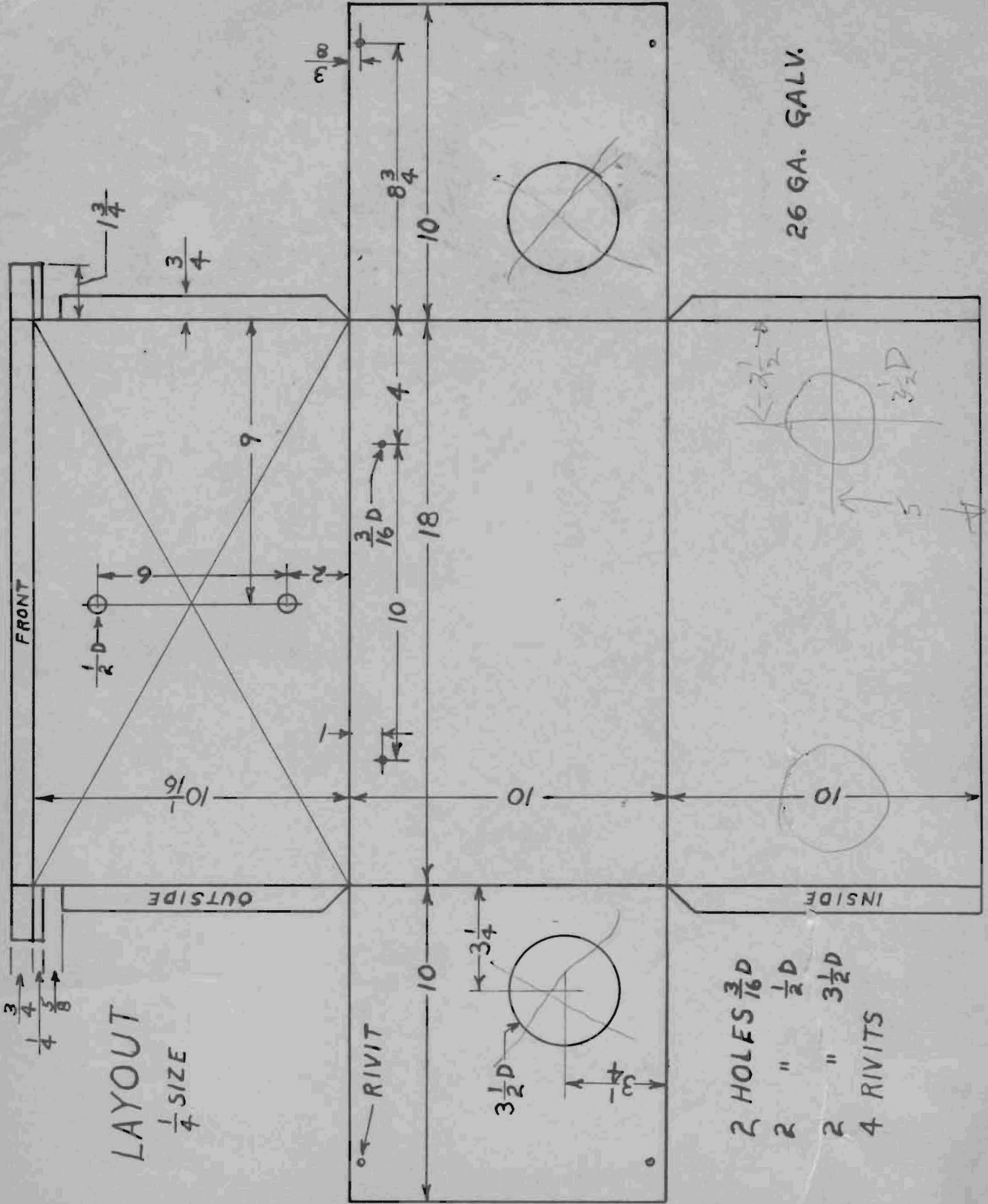

LAYOUT
1/4 SIZE

26 GA. GALV.

- 2 HOLES 3/16 D
- 2 " 1/2 D
- 2 " 3 1/2 D
- 4 RIVETS

COUPLER BOX

$\frac{1}{4}$ SIZE

24 ga.

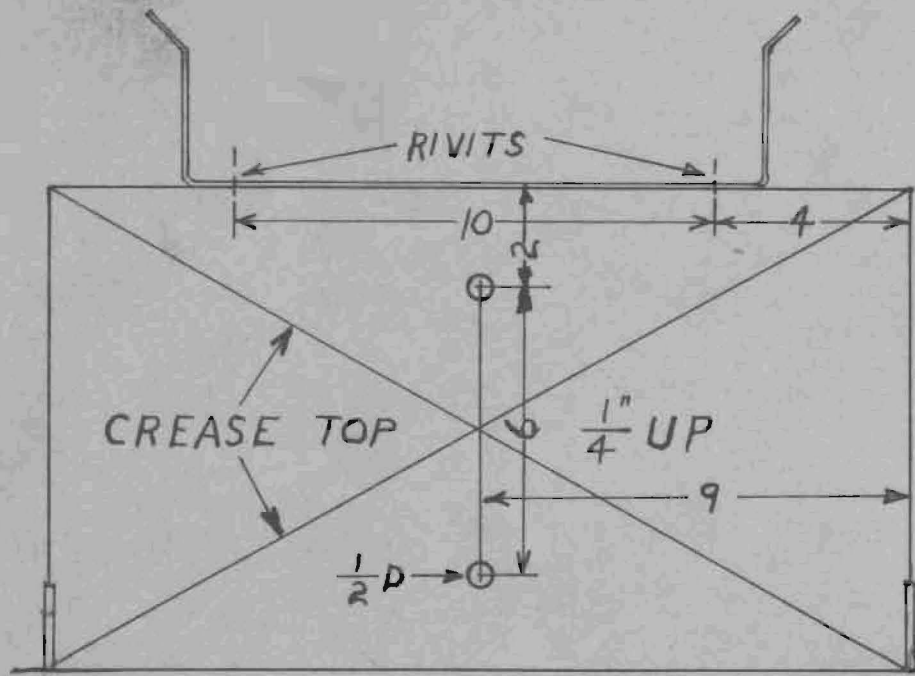

FLANGE WITH TIGHT CORNERS OVER COVER

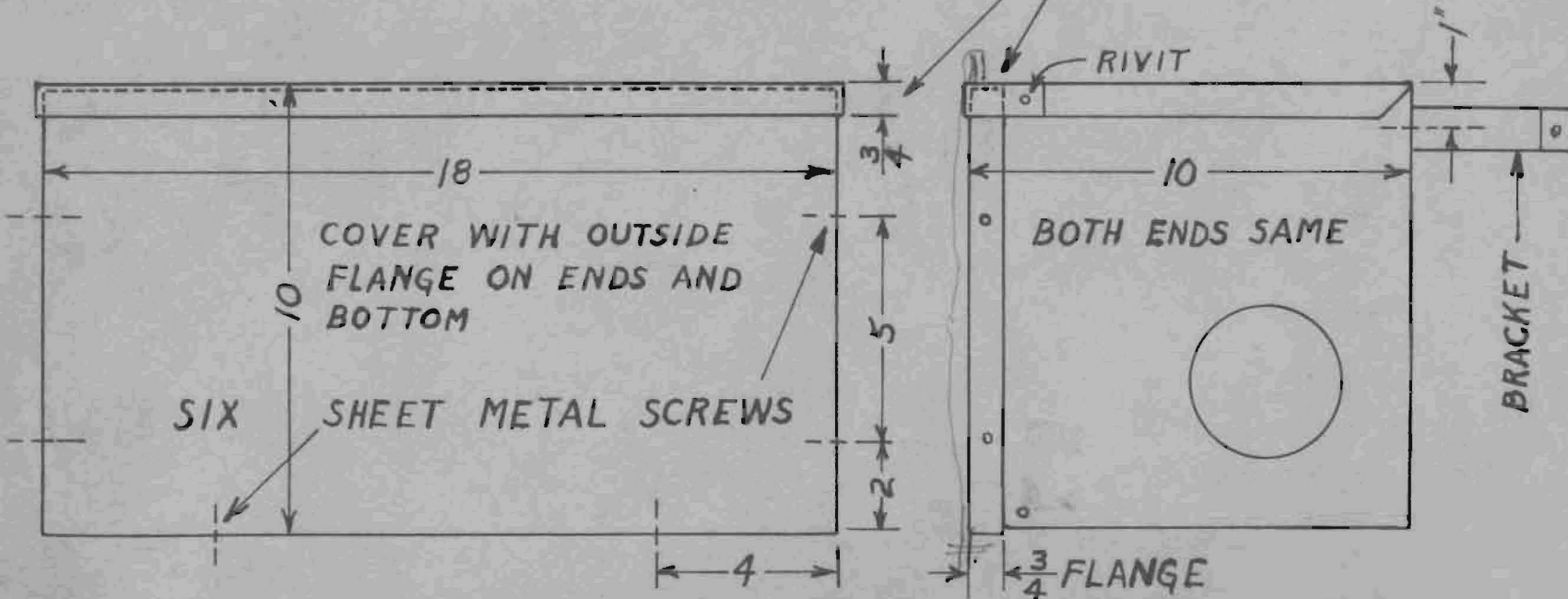

COUPLER BOX

$\frac{1}{4}$ SIZE

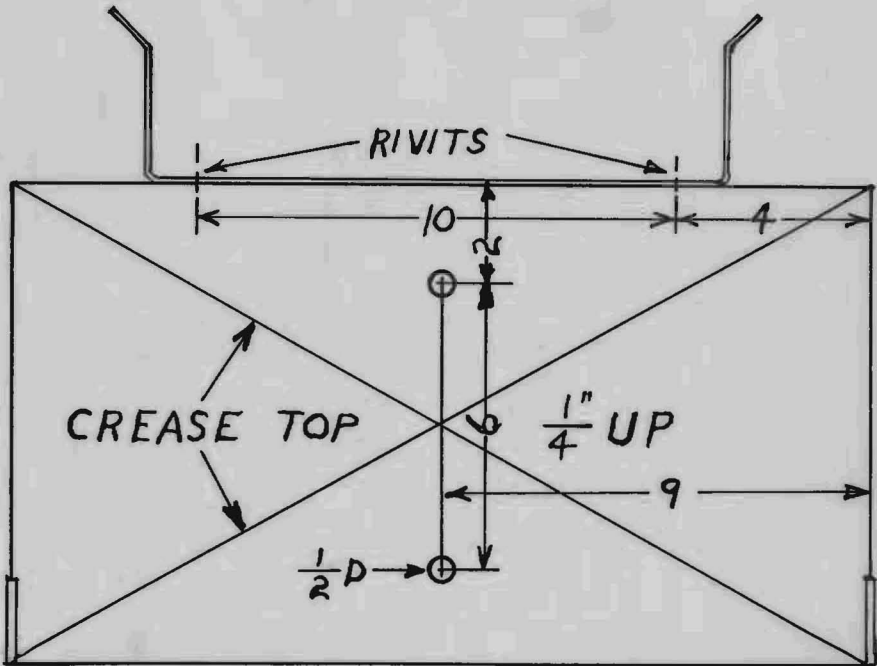

FLANGE WITH TIGHT CORNERS OVER COVER

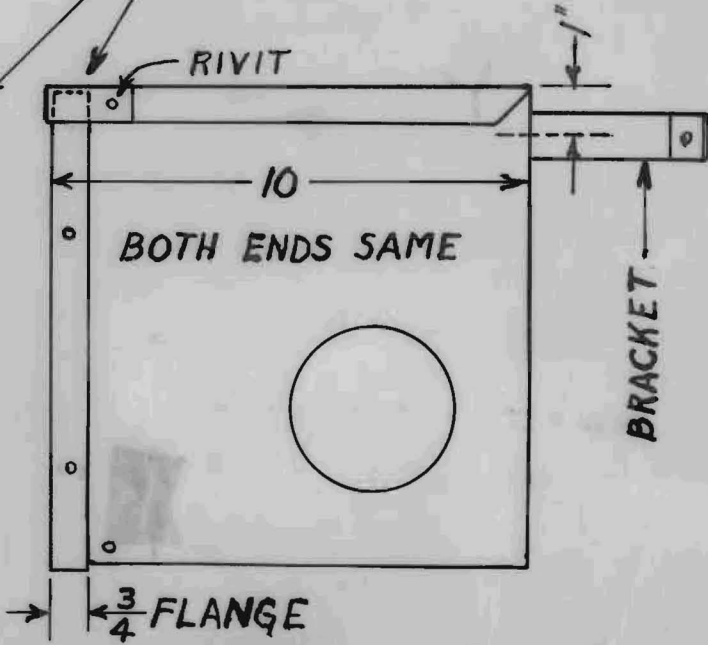
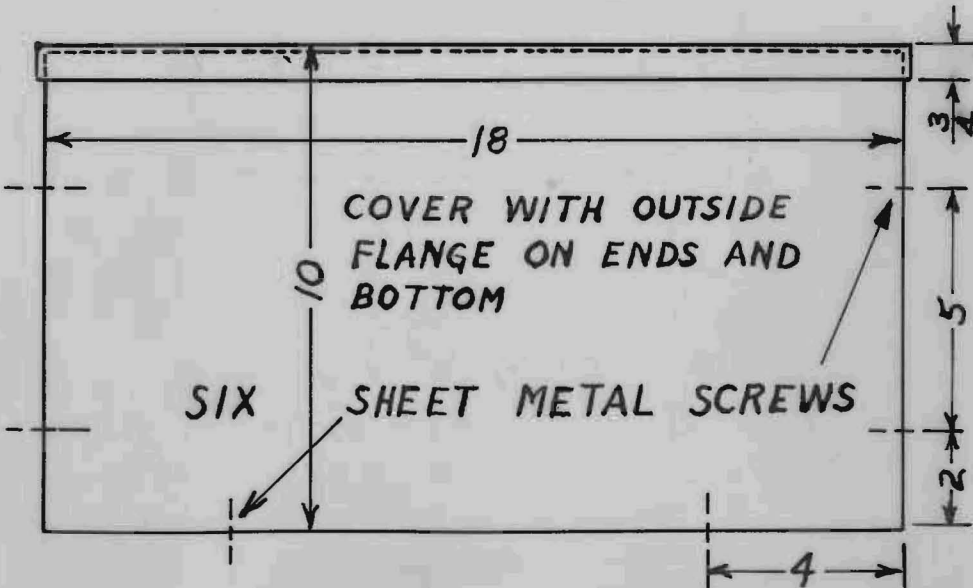

BRACKET $\frac{1}{2}$ SIZE

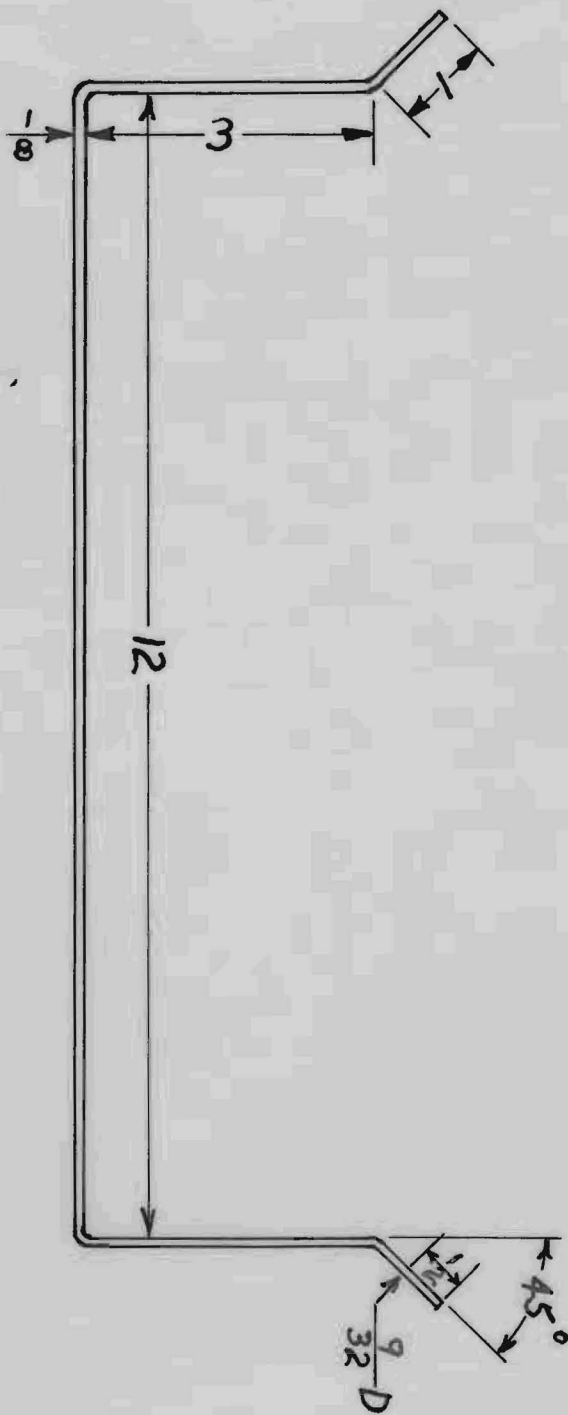

Tel 25044

B:NMD

24th November, 1961.

TASMANIAN Metalware Products Ltd.,
153 Campbell Street,
HOBART.

Attention: Mr. D. Webb.

Dear Sirs,

Your quotation of the 22nd for 100 metal boxes according to sample @ £1:15: - each is hereby accepted. These boxes are to incorporate the alterations described in our letter of the 16th.

The sample box, special Drill bit and 100 brackets will be delivered by our truck on Tuesday the 28th. The invoice is to be sent to this office for the account of Dr. G. Reber.

Delivered about on 28/11/61

Yours faithfully,

M.E. Bennett
Clerical Officer.

9/1/62 Webb said they had been on vacation. Nothing done. The fellows would be back tomorrow. He would get on to job.

26/1/62 Spid work in progress, all would be finished about 31st. He would call us & tell us.

CLAMP

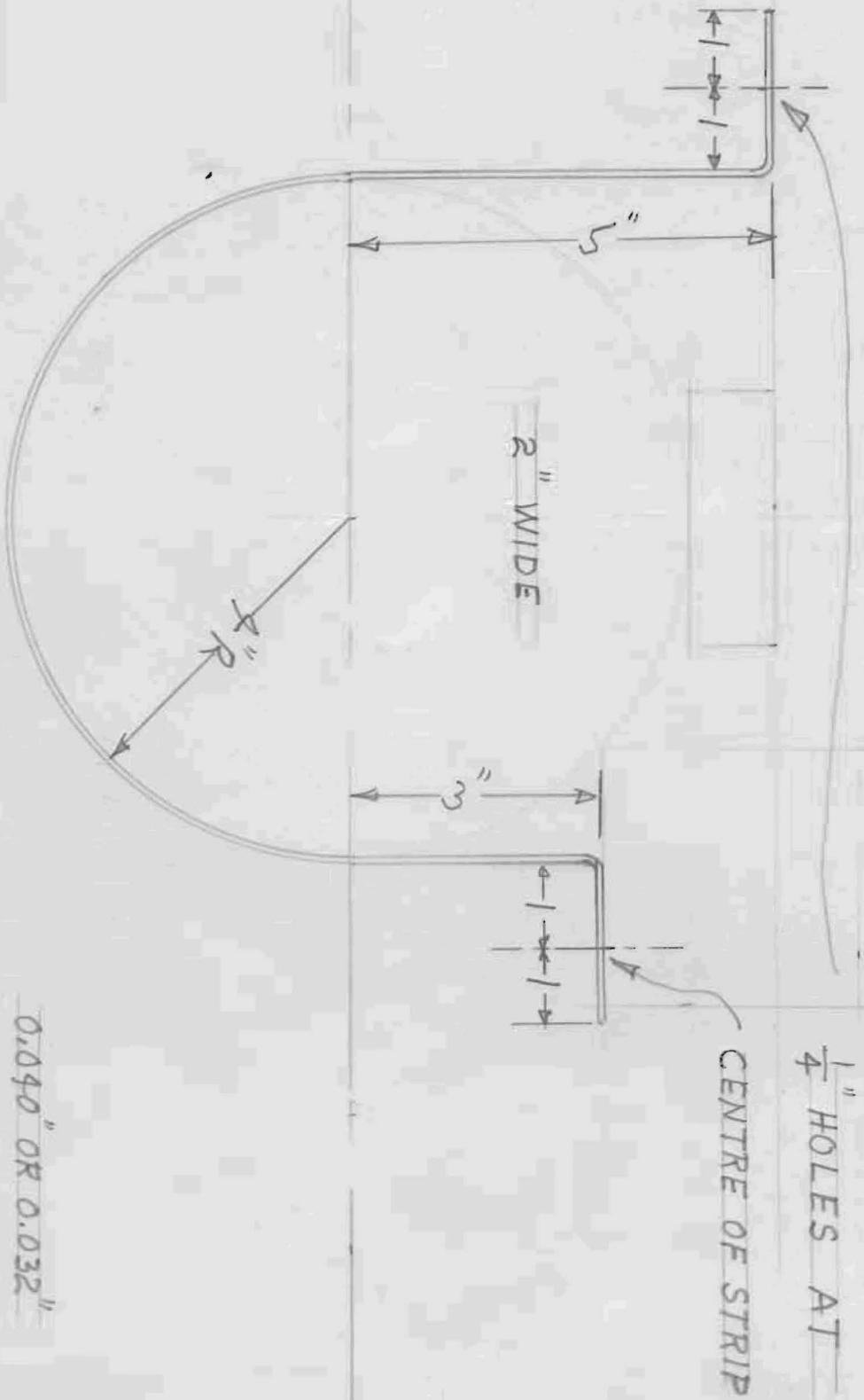

1/4" HOLES AT

CENTRE OF STRIP

0.040" OR 0.032"

ALUMINIUM

18

BAND

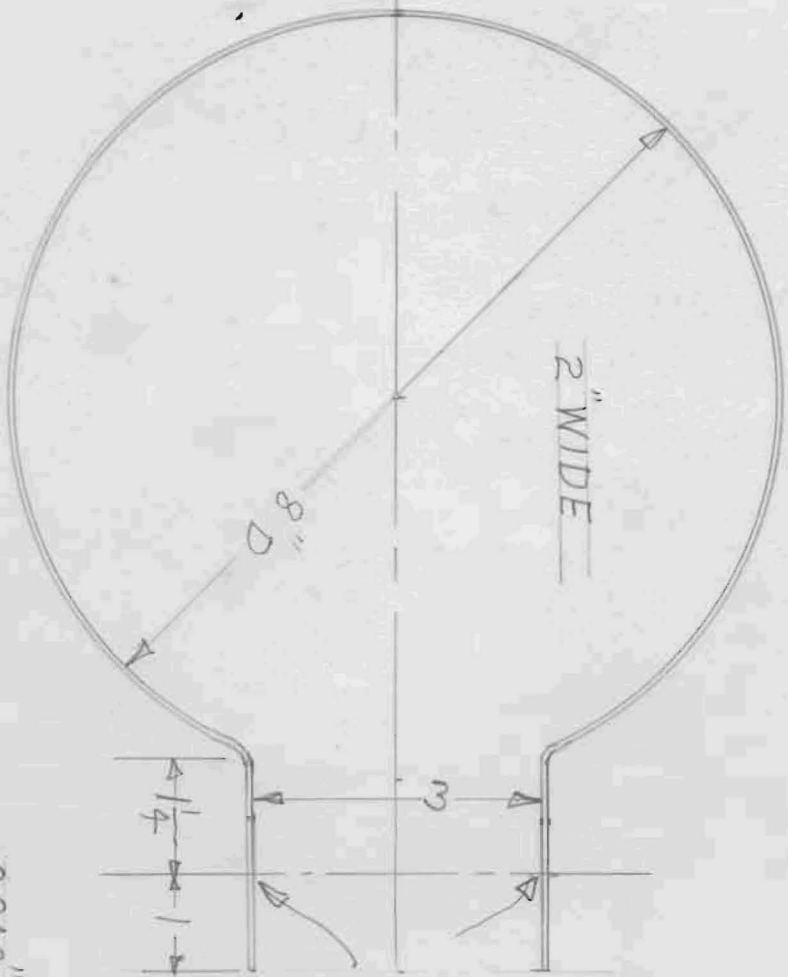

1/4" HOLES AT

CENTRE OF STRIP

0.040" OR 0.032"
ALUMINIUM

Grate Belva
C.S.I.R.O

(78)

13c

Red Fibre Washers for between screws & straps

8 washers $\frac{7}{16}$ " O.D. x .172 I.D. x .036 thick.

711 per pound. Use for $\frac{1}{8}$ " x $\frac{1}{2}$ " brass roundheads.