

3 1/4

BOOK FOLD 2

BOOK FOLD 3

BOOK FOLD 4

BOOK FOLD 5

P-

FOR BECK
DRAWN BY BENNETT
ISSUE 1 10-29-63

LOOSE PRINT FOLD 1

FOLD BOOK

LOOSE PRINT FOLD 4

1 B-608252

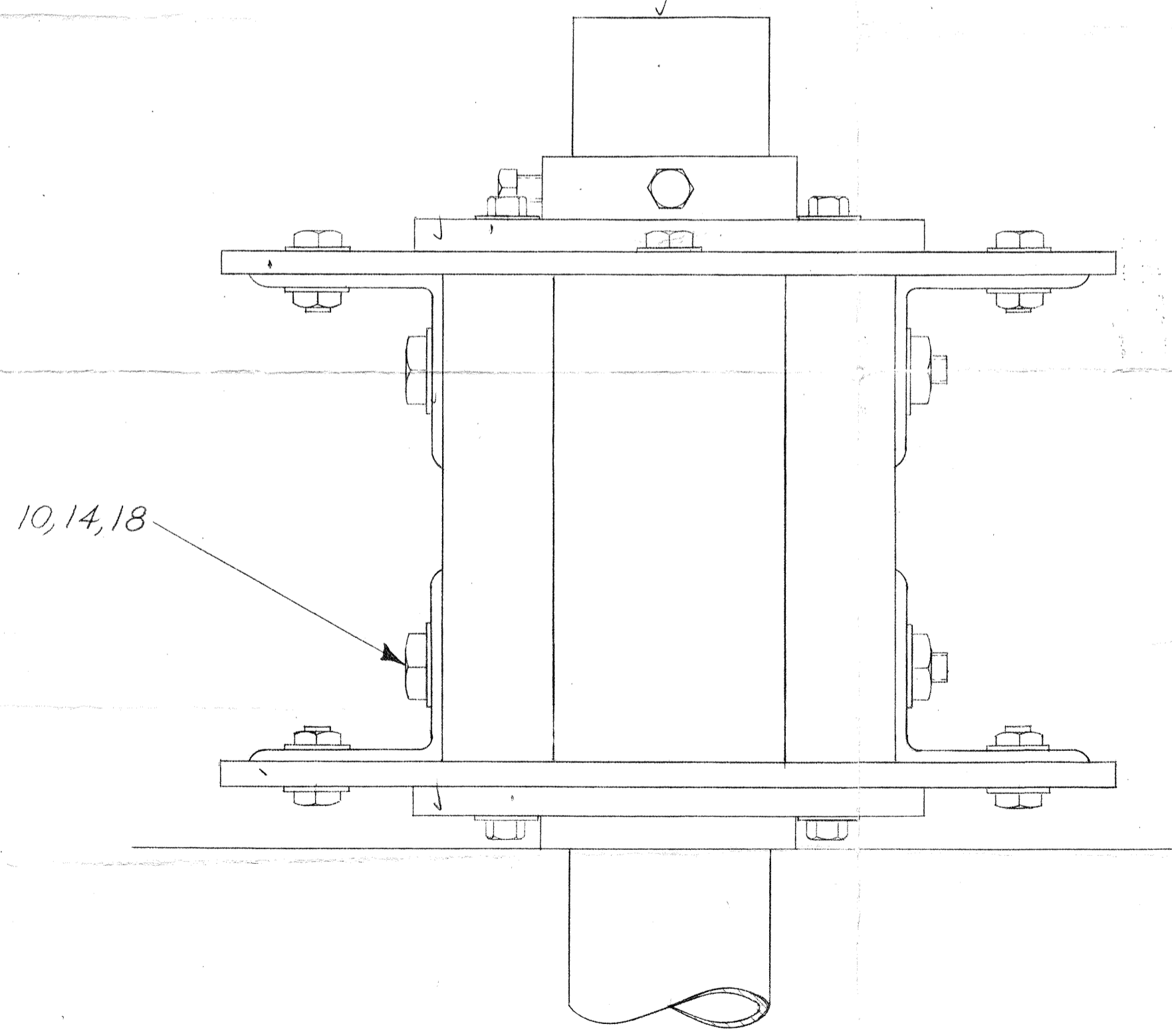
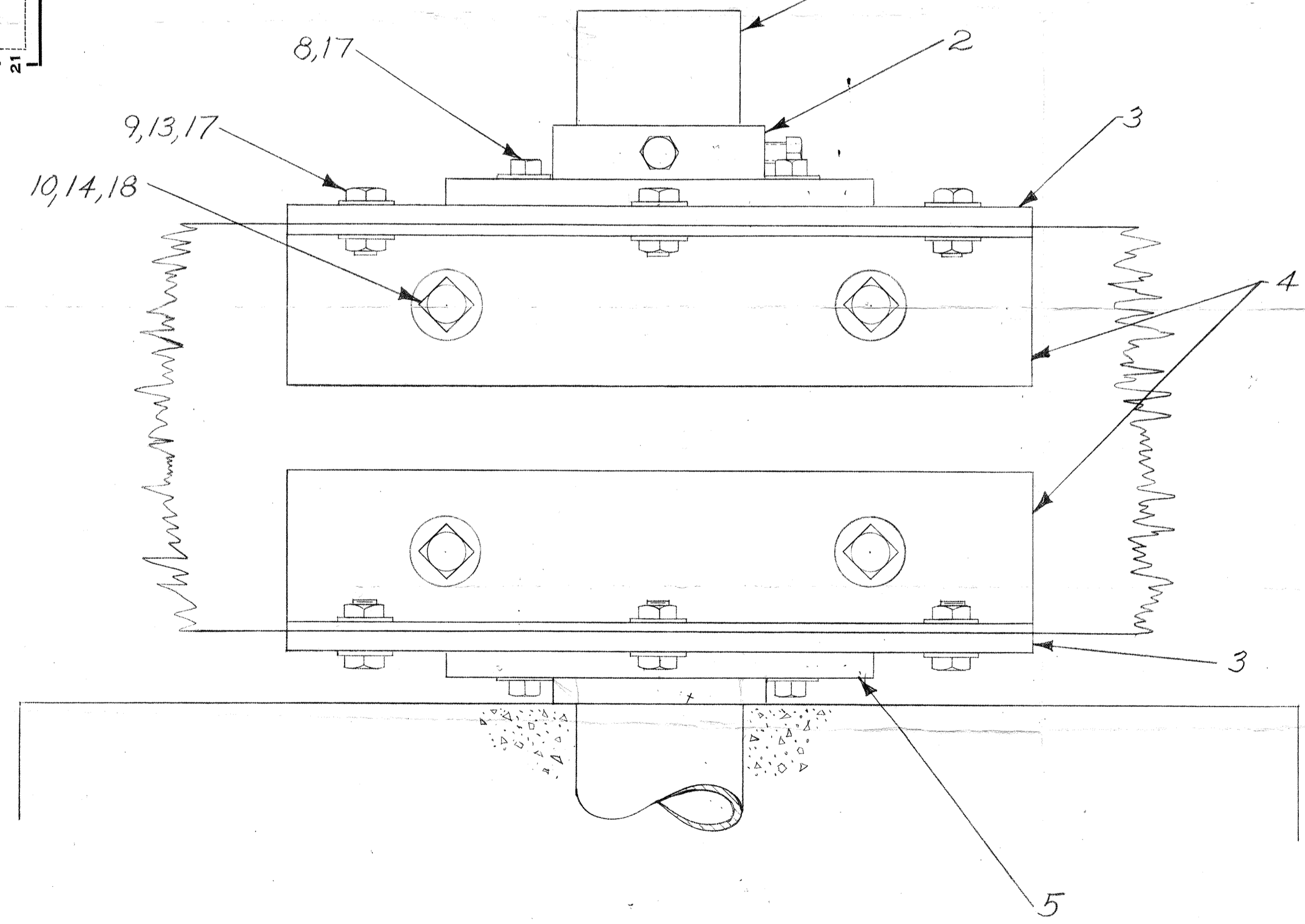
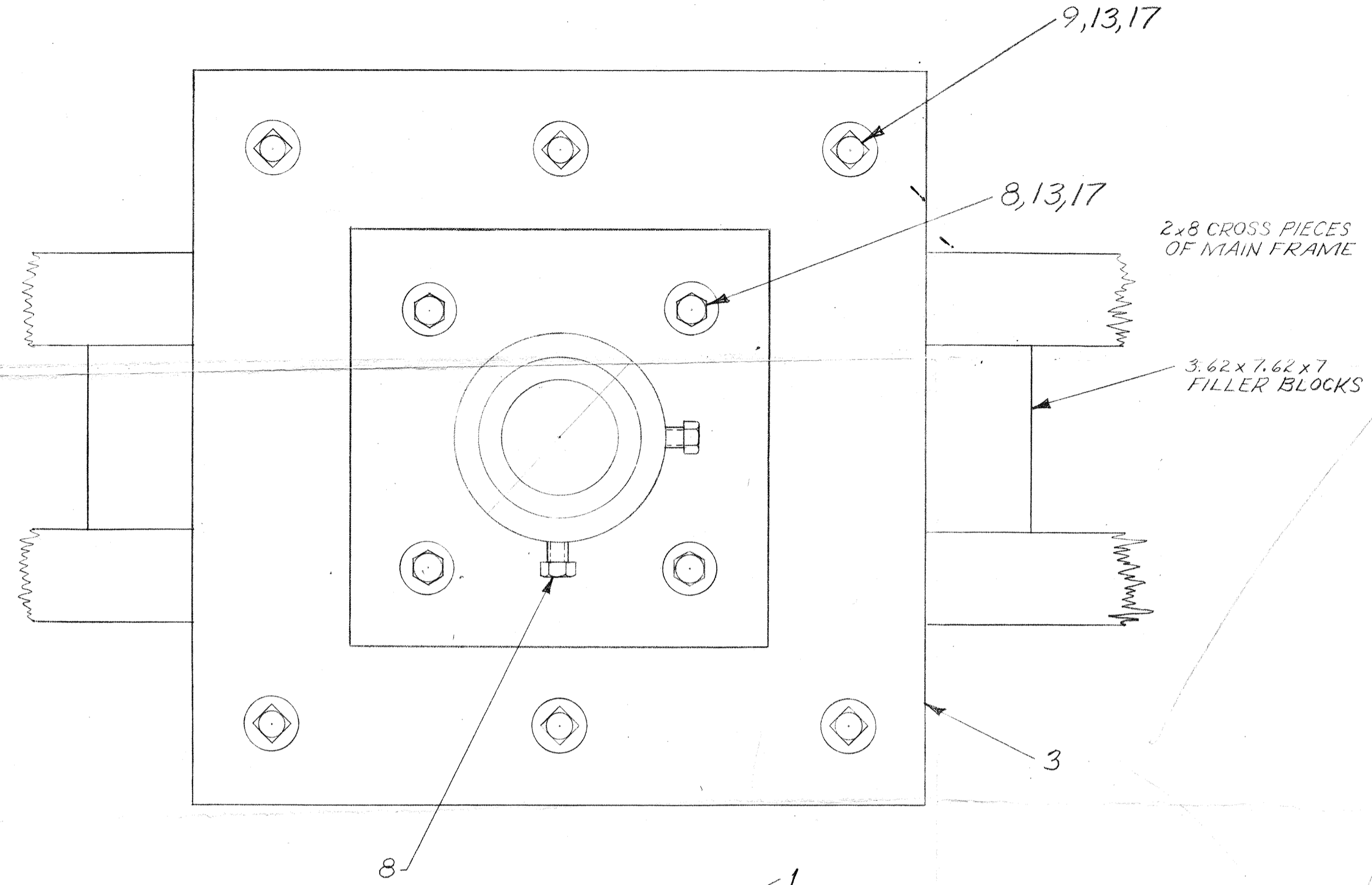

18	WASHER, PLAIN-STL, 17/32x1 1/16x.095	8	
17	WASHER, PLAIN-STL, 7/16x 7/8x.083	32	
16			
15			
14	NUT, REG SQ, STL, .500-13	4	
13	NUT, REG SQ, STL, .375-16	6	
12			
11			
10	BOLT, REG SQ H, STL, .500-13x 8	4	
9	BOLT, REG SQ H, STL, .375-16x 1	12	
8	SCR, HEX H CAP, STL, .375-16x 7/8	10	
7			
6			
5	B-608251 PLATE	2	
4	B-608250 ANGLE	4	
3	B-608249 PLATE	2	
2	B-608242 COLLAR	1	
1	B-608241 CENTER POST	1	
ITEM	PIECE	NAME	REQ

USED ON DWG

CENTER BEARING ASSEMBLY, JANSKY ANTENNA

SCALE 1/2

WESTERN ELECTRIC CO. INC.
ENGINEER OF MANUFACTURE
CENTRAL OFFICE EQUIPMENT

STOCK LIST

UNLESS OTHERWISE SPECIFIED, ALL DIMENSIONS ARE IN INCHES. NONLIMITED DIMENSIONS OTHER THAN SIZE OF RAW MATERIAL SHALL BE HELD AS FOLLOWS WHEN EXPRESSED TO 2 DECIMAL PLACES ±

AS ANGLES ±

TO 3 DECIMAL PLACES ±

FOR GENERAL INFORMATION ON SYMBOLS AND NOTES REFER TO MANUFACTURING STANDARD 16.003, PART 2, SECTION 227. (THIS NOTE IS NOT APPLICABLE TO CENTRAL OFFICE EQUIPMENT.)

DWG SIZE 6S

BELL TELEPHONE LABORATORIES INCORPORATED

C D S P- B-608252