

Noise Temperatures and Conversion Losses of Submicron GaAs Schottky-Barrier Diodes

H.-W. Hübers¹, T. W. Crowe², G. Lundershausen¹, W. C. B. Peatman², H. P. Röser¹

1) *Max-Planck-Institut für Radioastronomie, Auf dem Hügel 69,
D-5300 Bonn 1, Germany*

2) *Semiconductor Device Laboratory, University of Virginia,
Charlottesville, VA 22903, USA*

Abstract

We have determined system noise temperatures, mixer noise temperatures and conversion losses of two whisker-contacted submicron GaAs Schottky-barrier diodes at THz frequencies. Both diodes were fabricated with new technologies and have thin epitaxial layers with depletion thicknesses close to the optimum value of about 300 Å. The diodes have exceptional performance as THz mixer elements with noise temperatures and conversion losses 2-3 times below the best previous reported values. The effect of cooling on the diode performance is also investigated.

1 Introduction

A wealth of molecular and atomic transitions are in the THz frequency range, which consequently leads to its great importance for radio astronomy and atmospheric research. For high sensitivity and high spectral resolution measurements, THz heterodyne receivers are used [1]. The heart of this receiver is the mixer element. Above 800 GHz GaAs Schottky-barrier diodes are by far the most sensitive devices for this purpose. Therefore, the development of low noise Schottky diodes is of major importance and will have great impact on radio astronomy as well as atmospheric research.

In this work we report measurements of system noise temperatures T_{sys} , mixer noise temperatures T_{mix} and conversion losses L of two whisker-contacted GaAs Schottky-diodes, called 1T14 and 1T15. The diodes were manufactured at the University of Virginia and the National Nanofabrication Facility at Cornell University using direct-write electron beam lithography [2]. This results in a smaller diode geometry (e.g. 0.25 μm anode diameter of the 1T15), lower capacitance and higher cutoff frequency (see fig. 1). Of main importance are the thin epitaxial layers of 450 Å (1T14) and 300 Å (1T15) and depletion thicknesses close to the optimum value of about 300 Å determined by Roeser et al. [3]. At 803 GHz we have determined the system noise temperature of the diode 1T14 as a function of temperature.

2 Measurement System and Method

Measurements were performed at three different frequencies: 803 GHz, 1397 GHz and 2547 GHz by using laser lines of $^{15}\text{NH}_3$ and CH_2F_2 . An optically pumped far-infrared ringlaser served

D I O D E	1 I 12	1 T 14	1 T 15
ANODE DIAMETER [μm]	0.45	0.5	0.25
EPITAXIAL LAYER THICKNESS D_{epi} [\AA]	600	450	-300
DEPLETION THICKNESS AT ZERO BIAS D_{depl} [\AA]	500	-380	-300
EPITAXIAL LAYER DOPING $N_D \times 10^{17}$ [cm^{-3}]	4.5	10	10
CAPACITY AT ZERO BIAS C_j [fF]	0.45	0.8-0.9	0.25
SERIES RESISTANCE R_S [Ω]	33	8-12	-20
CUT-OFF FREQUENCY ν_{CO} [THz]	11	15-25	32

Figure 1: Geometrical and electrical parameters of the Schottky-diodes 1I12, 1T14 and 1T15. The capacitances are measured values.

as the local oscillator. Compared to a conventional standing wave resonator, the ringlaser has a higher amplitude and frequency stability [4]. The laser beam and the signal from a hot/cold load were spatially superimposed by a Martin-Puplett diplexer and focused onto the diode by an off axis parabola. The diodes were mounted in a 4λ corner cube mixer block. The low noise HEMT amplifier of the first amplification stage operated at an IF frequency of 1.55 GHz (bandwidth: ± 20 MHz) and was cooled to 20 K. Its noise temperatures were 35 K (803 GHz, 1397 GHz) and 130 K (2547 GHz).

Cooling of the Schottky-diode was done with a cryocooler (CTI Cryogenics) with the diode mounted directly on the cold head. The temperature could be varied from 300 K to 20 K and was measured and stabilized with a Si-diode temperature controller (Lake Shore Cryotronics). For calibration this diode was mounted in a dummy mixer block at the position of the Schottky diode.

The system noise temperature T_{sys} has been measured by the total power method using black bodies at room temperature and at liquid nitrogen temperature. A directional coupler with an additional noise diode was used to measure the impedance mismatch (see fig. 2). According to the equations given by Stimson et al. [5] and according to

$$T_{\text{sys}} = T_{\text{mix}} + L * T_{\text{if}} \quad (1)$$

we have determined T_{mix} and L from the measured impedance mismatch and T_{sys} .

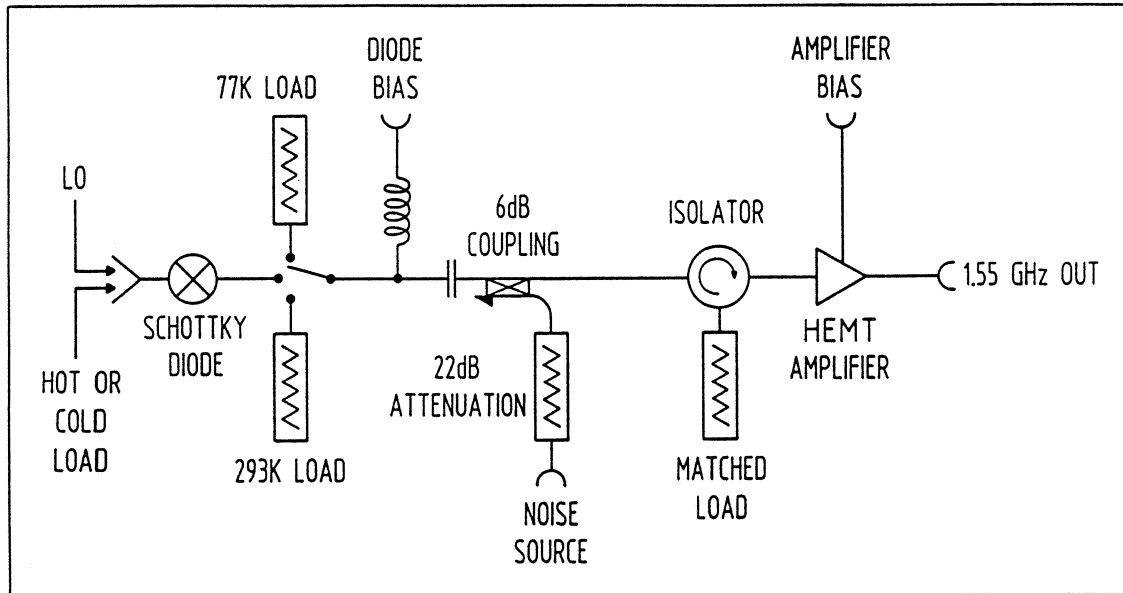

Figure 2: Block diagram for the calibrated heterodyne measurements.

3 Results

Both diodes show exceptional sensitivity (see fig. 3), which is 2–3 times better than the best previous reported results [6], [7]. Mixer noise temperatures and conversion losses are also a factor of 2–3 better than before. Figure 4 gives a summary of the main results. All values are DSB and are corrected for atmospheric losses.

At 803 GHz the diode 1T14 is the best. Its T_{mix} of 1100 K is only a factor of 29 above the quantum limit in terms of $h\nu/k$ but this ratio increases with frequency to 70 at 2547 GHz. T_{sys} (1200 K) and L (5.3 dB) at 803 GHz are also remarkably low. At higher frequencies the diode 1T15 is superior. Its quantum efficiency (defined as $\eta = kT_{mix}/h\nu$) decreases from 43 at 803 GHz to 34 at 2547 GHz. But the required local oscillator (LO) power of 1–12 mW is still high.

Figure 5 shows the improvement of T_{sys} with decreasing temperature, which is essentially due to the decreasing IF temperature. T_{mix} changes insubstantially with temperature. This is demonstrated by a comparison of the system noise temperatures of the same diode with the same contact and the same cooled HEMT amplifier at room temperature and at 20 K. But it is important to note that in the cooled diode–amplifier configuration, the diode impedance was not matched to the amplifier whereas the warm diode was matched to the amplifier.

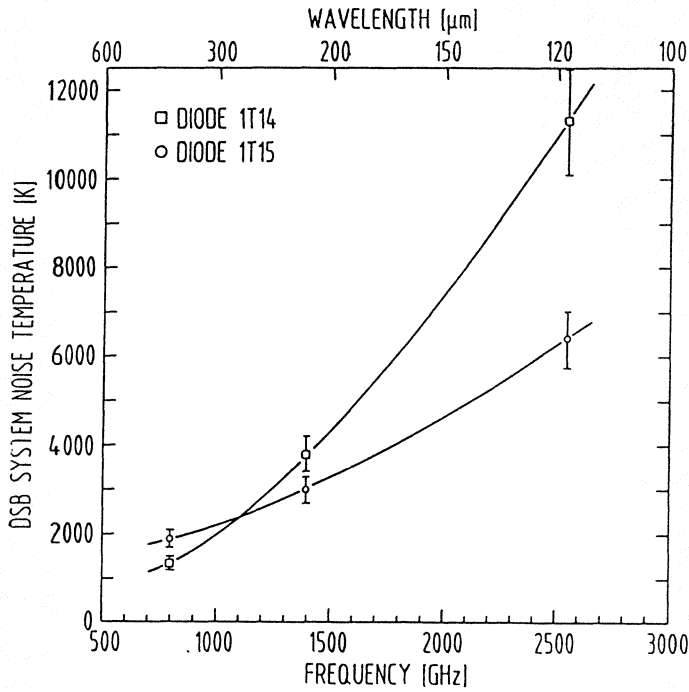

Figure 3: System noise temperature of the Schottky-diodes 1T14 and 1T15 at room temperature as a function of frequency

DIODE 1T14	803GHz	1,397GHz	2,547GHz
$T_{SYS}(K)$	1,200	3,700	11,300
$T_{MIX}(K)$	1,100	3,400	8,500
$L(dB)$	5.3	9	-13
$P_{LO}(mW)$	1	8	12

DIODE 1T15	803GHz	1,397GHz	2,547GHz
$T_{SYS}(K)$	1,900	3,000	6,400
$T_{MIX}(K)$	1,700	2,600	-4,100
$L(dB)$	6.5	9	-12.5
$P_{LO}(mW)$	1	1	10

Figure 4: System noise temperature, mixer noise temperature, conversion loss (DSB values) and required LO power for the diodes 1T14 and 1T15 at 803 GHz, 1397 GHz and 2547 GHz. At 803 GHz and 1397 GHz the IF noise temperature was 35 K whereas at 2547 GHz it was 130 K.

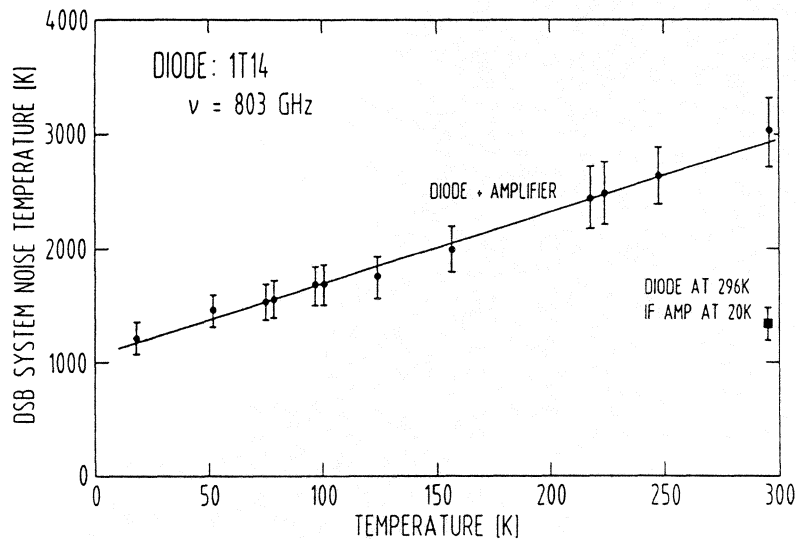

Figure 5: System noise temperature of the diode 1T14 at 803 GHz as a function of temperature. For comparison the system noise temperature of the same diode at room temperature but with a cooled (20 K) amplifier is also shown. Note, $T_{if}=200$ K at room temperature and $T_{if}=35$ K at 20 K.

4 Discussion

Experiments have shown that when the diode bias and LO power are adjusted for optimum heterodyne receiver sensitivity at a given frequency, ν , the average number of electrons that pass through the Schottky contact during each LO cycle is a constant, N_e [3]. This behaviour is expressed by the experimentally obtained equation for the optimum mixing current, I_{opt}

$$I_{opt} = N_e e \nu, \quad (2)$$

where N_e does not vary with frequency, but rather is a constant for each diode type. The constant charge, $N_e e$, transferred through the diode each LO cycle can be related to the diode area, A , and epitaxial doping density, N_d , according to

$$N_e = (A D_{depl}) N_d. \quad (3)$$

It has also been shown that the voltage drop, V_{LO} , across the diode due to the LO power at the optimum bias current for mixing is independent of the LO frequency [3],

$$V_{LO} = \text{constant}. \quad (4)$$

A voltage drop of this amount can be expressed in terms of a depletion depth in the Schottky contact as

$$V_{LO} = (D_{depl}^2 e N_d) / 2\epsilon_s, \quad (5)$$

where ϵ_s is the dielectric permittivity of GaAs. Equations (3) and (5) both yield a depletion depth of about 300 Å for a variety of diodes tested. It appears that for a given diode a specific number of electrons, N_e , take part in the mixing process each LO cycle, regardless of the frequency. The same behaviour has been confirmed with our new diodes.

A comparison of these new results with the best previous diode, 1112, shows that the increase in doping density and the reduction of the epitaxial layer thickness has led to significant improvements in performance. Since the new diodes have epitaxial layer thicknesses close to the value of D_{depl} obtained above, it may be that this is the primary reason for the improved performance. Also, since the epitaxial layer thickness is well below the mean free path in GaAs (typically 500–1000 Å [8]) and the Debye length $l_d < 150$ Å [8], it is possible that ballistic transport effects are becoming more important.

It is worth noting that at 803 GHz the antenna coupling loss of about 3 dB [9] is the main contribution to the mixer conversion loss of 5.3 dB. This loss can be decreased by the addition of a conical horn in the corner cube configuration, which lowers the system noise temperature about 30% [10]. Therefore, a DSB system noise temperature at 803 GHz below 1000 K seems to be achievable.

5 Summary

Record noise temperatures and conversion losses were measured, corresponding to quantum efficiencies as low as $T_{mix} = 29h\nu/k$ (803 GHz), $38h\nu/k$ (1397 GHz) and $34h\nu/k$ (2547 GHz).

These results fit in the previous work [3] which indicated that a specific number of electrons per LO cycle participate in the mixing process for a given diode type regardless of the frequency. It is also clear that increased epitaxial doping and reduction of the diode epitaxial layer thickness to approximately 300 Å has led to substantially improved performance. Reduction of the diode temperature to 20 K led to no substantial improvement in the mixer noise temperature. At 803 GHz a DSB system noise temperature below 1000 K ($26 h\nu/k$) seems to be achievable with an improved antenna configuration.

Acknowledgements: We thank Ken Zelin for assisting with the diode fabrication and Walter Esch for technical support during the experiments.

References

- [1] H. P. Röser, *IR Physics*, vol. 32, pp. 385–407, 1991
- [2] W. C. B. Peatman, P. A. D. Wood, D. Porterfield, T. W. Crowe, M. J. Rooks, *Appl. Phys. Lett.*, vol. 61, no. 3, pp. 294–296, 1992
- [3] H. P. Roeser, R. U. Titz, G. W. Schwaab, M. F. Kimmitt, *J. Appl. Phys.*, vol. 72, no. 7, pp. 3194–3197, 1992
- [4] H. K. E. Stadermann, P. B. van der Wal, *Proc. 16th Int. Conf. IR and MM Waves*, Lausanne, 1991
- [5] P. A. Stimson, R. J. Dengler, P. H. Siegel, H. G. LeDuc, *Proc. 3rd Symp. Space THz Tech.*, Ann Arbor, USA, 1992
- [6] R. U. Titz, H. P. Röser, G. W. Schwaab, H. J. Neilson, P. A. Wood, T. W. Crowe, W. C. B. Peatman, J. Prince, B. S. Deaver, H. Alius, G. Dodel, *Int. J. IR and MM Waves*, vol. 11, no. 7, pp. 809–820, 1990
- [7] A. I. Harris, J. Stutzki, U. U. Graf, R. Genzel, *Int. J. IR and MM Waves*, vol. 10, no. 11, pp. 1371–1376, 1989
- [8] M. Shur, *GaAs Devices and Circuits*, Plenum Press, New York, 1987
- [9] B. Vowinkel, *Int. J. IR and MM Waves*, vol. 7, no. 1, pp. 155–170, 1986
- [10] H. Nett, Ph. D. thesis, University of Bonn, 1988