

TERAHERTZ RECEIVER WITH NbN HEB DEVICE (TREND) - A LOW-NOISE RECEIVER USER INSTRUMENT FOR AST/RO AT THE SOUTH POLE

K.S. Yngvesson, C.F. Musante, M. Ji, F. Rodriguez, and Y. Zhuang

Department of Electrical and Computer Engineering, University of Massachusetts at Amherst,
Amherst, MA 01003; yngvesson@ecs.umass.edu

E. Gerecht

Department of Astronomy, University of Massachusetts at Amherst,
Amherst, MA 01003; gerecht@astro.umass.edu

M. Coulombe, J. Dickinson, T. Goyette, and J. Waldman

Submillimeter-Wave Technology Laboratory, University of Massachusetts at Lowell,
Research Foundation, Lowell, MA 01854;

C. K. Walker

Department of Astronomy and Steward Observatory
University of Arizona, Tuscon, AZ

A. Stark and A. Lane

Smithsonian Astrophysical Observatory
Cambridge, MA 02138

ABSTRACT

Based on the excellent performance of NbN HEB mixer receivers at THz frequencies which we have established in the laboratory, we are building a *Terahertz REceiver with NbN HEB Device (TREND)* to be installed on the 1.7 meter diameter AST/RO submillimeter wave telescope at the Amundsen/Scott South Pole Station. *TREND* is scheduled for deployment during the austral summer season of 2002/2003. The frequency range of 1.25 THz to 1.5 THz was chosen in order to match the good windows for atmospheric transmission and interstellar spectral lines of special interest. The South Pole Station is the best available site for THz observations due to the very cold and dry atmosphere over this site. In this paper, we report on the design of this receiver. In particular, we report measured beam patterns and polarization sensitivity at THz frequencies for a log-periodic antenna/lens combination, accurate measurements of the frequencies of two laser lines which are suitable for two of the spectral lines of greatest interest (NII and CO), as well as the mixer block design and other aspects of the design of the receiver system.

I. INTRODUCTION

We will describe the work done so far on the TREND project, which will build and install a low-noise THz receiver on the 1.7 meter diameter AST/RO submillimeter wave telescope at the South Pole. Most of the work has dealt with issues such as the development of a laser local oscillator, and characterizing the quasi-optical lens/antenna system in order to match it to the telescope. We plan to begin installing the receiver in the fall of 2002, and commence observations during the austral winter of 2003.

II. SITE CONSIDERATIONS

Terahertz astronomy will eventually be pursued with the help of HEB low-noise receivers from platforms in space (FIRST), or in the upper atmosphere (SOFIA, balloons). Until that time, it is important to gain experience of this new technology by installing and employing HEB receivers on ground-based telescopes at the best available sites. It has only recently been realized that observations above 1 THz are feasible at such sites. One can also support an argument in favor of continuing the use of such receivers on ground based telescopes in the future, given the fact that they can be dedicated to specific tasks for longer periods of time compared with facilities such as SOFIA or FIRST, and that larger diameter telescopes are feasible, such as the proposed 10 meter telescope at the South Pole Station [1]. Presently, the 1.7 meter diameter AST/RO submillimeter wave telescope is operated at the South Pole by the Smithsonian Astrophysical Observatory [2], and has been successfully used up to the 800 GHz (350 μm) window for several years (see for example the paper by C. Walker et al. at this symposium [3]).

The Antarctic Plateau, with an altitude of 2847 meters, is unique among observatory sites for unusually low wind speeds, absence of rain, and an extremely cold and dry atmosphere. The median Precipitable Water Vapor (PWV) value is less than 0.3 mm during the austral winter season. Available atmospheric models can be used with the measured amount of PWV to predict the atmospheric transmission in two windows near wavelengths of about 200 μm , occurring from about 1.25 THz to 1.4 THz, and from 1.45 THz to 1.6 THz [4]. Expected *median* transparency at frequencies corresponding to important spectral lines is from 5 % to 11 %, and on unusually good days may reach values 2 or 3 times higher than this. Fourier transform spectrometer measurements were performed in this frequency range at another site, Chajnantor in the Atacama desert, Northern Chile, planned for the ALMA millimeter array. These measurements show similar atmospheric transparency and confirm the above model predictions. However, the good conditions for THz observations at the South Pole are available more often than in the Atacama desert and for more extended periods of time. The Chajnantor measurements are shown in Figure 1 [5]. It is clear that installing a low noise THz receiver at the South Pole site is thus well justified.

We have identified three spectral lines in the above atmospheric windows, which are of special interest: (i) NII (singly ionized nitrogen) at 1461.3 GHz (205 μm), the second strongest spectral line overall in a typical galaxy (only CII at 156 μm is stronger); NII should be ubiquitous in the interstellar medium (ISM) of our galaxy, especially its warm ionized component; (ii) H_2D^+ at 1370.0853 GHz, an important probe for gas phase chemistry; and (iii) the J=13 \rightarrow 12 and J=11 \rightarrow 10 lines of CO; the latter line is at 1267.014

GHz. It is important to observe higher order CO lines, and compare these with the well-studied millimeter lines of CO in warmer, denser sources. The locations of the spectral lines for the above three species relative to the atmospheric transmission spectrum are marked in Figure 1.

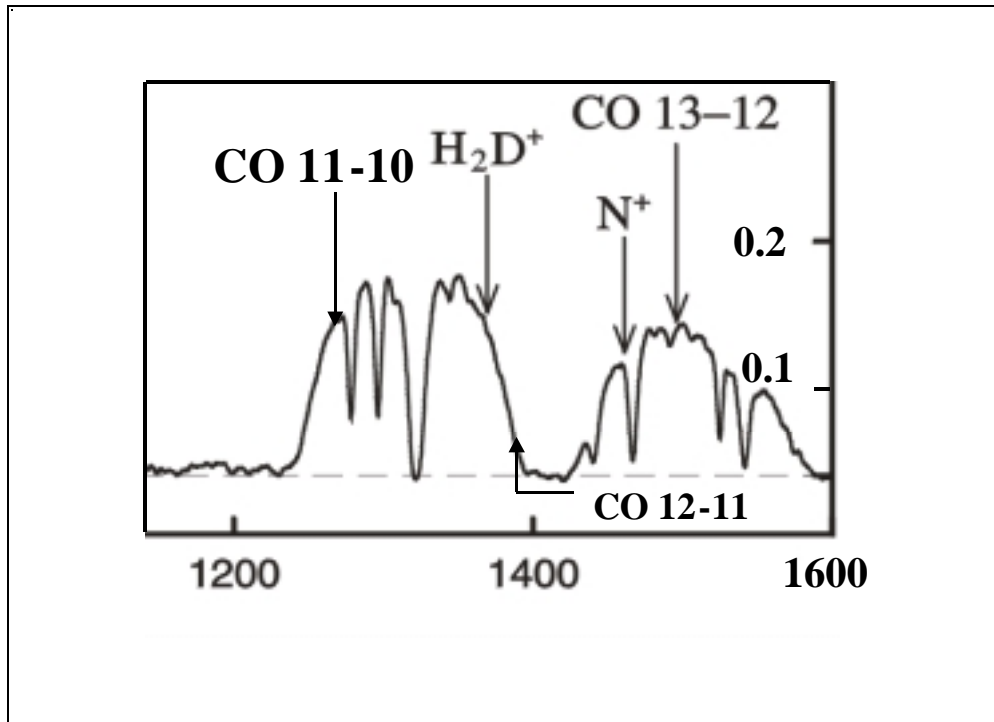

Figure 1. Atmospheric transmission from 1,200 GHz to 1,600 GHz at Chajnantor on a day with very low humidity, FTS measurement by SAO Submillimeter Receiver Lab. [5]

III. RECEIVER DESIGN

A. General considerations

Waveguide-coupled NbN HEB mixers have been used on astronomical telescopes up to 1.04 THz [6] and have proven to be easy to operate in this environment. For the 200 μm window, we will make use of quasi-optical coupling as in most laboratory experiments with HEB mixers. The lowest receiver noise temperatures measured so far at about 1.5 THz are 500 K [7] and 650 K [8]. NbN HEB mixers are also very insensitive to changes in bias conditions and LO power and should be easy to adapt to the observing logistics at AST/RO, where all observations in the Austral winter season are performed by a single Post-doctoral scholar operator. Whereas multiplier LO sources are expected to be available in the future, a laser was chosen for TREND, since it is a mature technology in the THz regime and will lend itself well to a future upgrade of the system incorporating a multi-pixel focal plane array. Laser sources can also be made tunable over ± 100 GHz by using Sideband Generator Technology [9].

B. Active Device

Phonon-cooled HEB mixers are typically fabricated from NbN films on either silicon or MgO substrates. The MgO substrate has the advantage that the phonon transmission probability is higher than for NbN on silicon. Since the phonon escape time contributes substantially to the thermal time-constant of NbN bolometers, NbN mixers on MgO have wider IF bandwidth for a given NbN film thickness, t . There is also some evidence that NbN/MgO devices may yield lower receiver noise temperature [8]. We are testing films on both substrates and expect to choose the one which yields the lowest receiver noise temperature for the TREND receiver. The IF (conversion gain) bandwidth is typically 3 GHz for NbN/silicon, and up to 4.8 GHz for NbN/MgO [10]. It is important to note that the receiver *noise* bandwidth is about twice these numbers. As explained in section D below, we expect to be able to accommodate the three target spectral lines within an IF band of about 1.3 GHz to 2.3 GHz; the IF bandwidth thus poses no problem for either material combination. Future needs for other spectral lines which yield IF frequencies up to 5 to 6 GHz can easily be satisfied as well, with a change of IF amplifier. Present devices are $1\ \mu\text{m} \times 5\ \mu\text{m}$ and are fabricated with UV lithography. Smaller devices can be made with e-beam lithography. Both processes are much simpler than the one required for diffusion-cooled HEBs.

C. Quasi-Optical Coupling

In our NbN HEB development work [7], we have made use of a quasi-optical coupling scheme consisting of a 4 millimeter diameter elliptical silicon lens, coupled to a self-complementary toothed log-periodic antenna on a silicon substrate, see Figure 2. The log-periodic antenna has a (design) bandwidth from about 300 GHz to 3.5 THz. The dielectric constant of MgO is very similar to that of silicon and it has been shown that devices on MgO substrates perform well with silicon lenses without modification [8]. Since the required RF bandwidth for TREND is only 1.25 THz to 1.5 THz, we have designed an alternative double-slot antenna and plan to use this antenna if it yields the same or a lower receiver noise temperature. Our NbN HEB mixers do not saturate on the total thermal noise picked up by the antenna. Moreover, choosing a double-slot antenna with a narrower bandwidth than the log-periodic antenna makes the receiver even less sensitive to saturation and direct detection effects. We will make use of a parylene AR coating in order to reduce the receiver noise temperature by about 30 %, as described in [11].

The beamwidth of the quasi-optical system is determined primarily by the diameter of the elliptical lens and has been measured by using a new method. The beam of a THz laser was expanded until it had a diameter of 5 cm (at the -3 dB level). The laser beam was injected through the window of the dewar onto the elliptical lens using a plane mirror

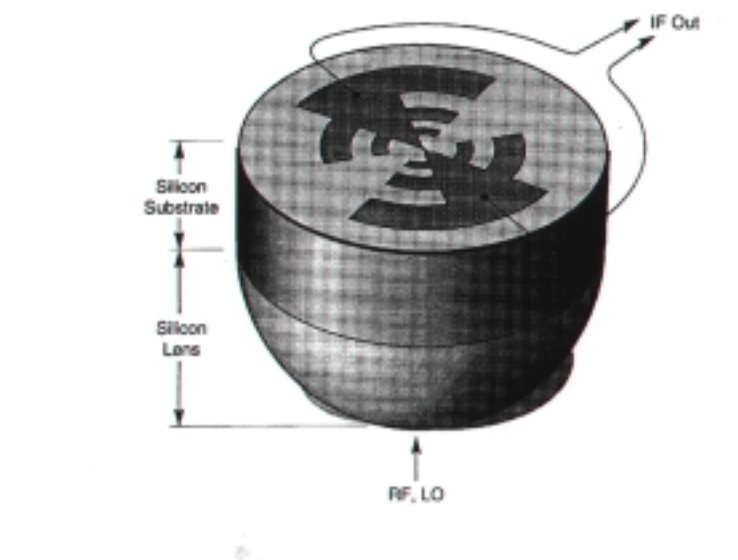

Figure 2. The logperiodic antenna coupled to the silicon lens

close to the dewar. The mirror could be turned in both the horizontal and the vertical plane, thereby changing the angle of incidence of the entire laser beam. The change in the

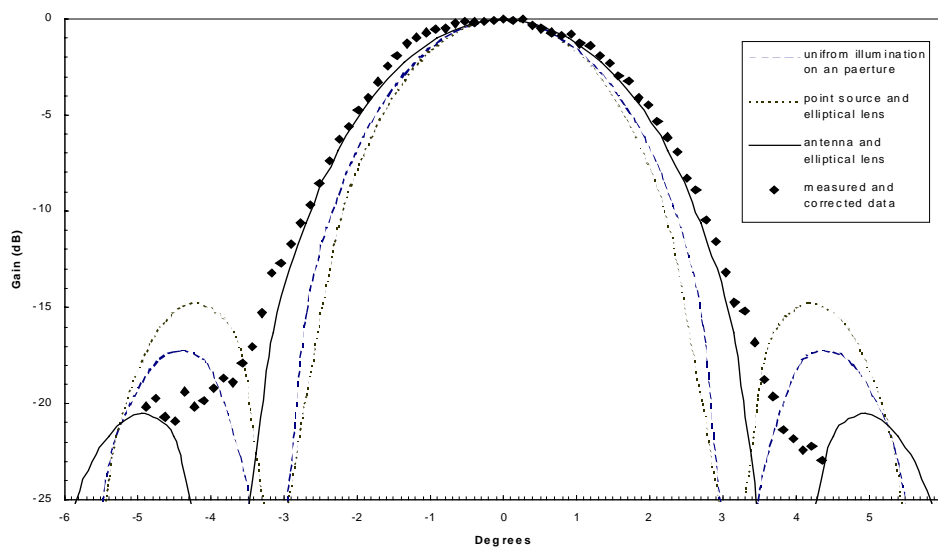

Figure 3. The radiation pattern in the H-plane for the log-periodic antenna/lens combination, measured at 1.56 THz.

actual angle of incidence at the position of the silicon lens can be calculated from the angle by which the mirror is turned if one knows the location of the center of curvature of the incident laser beam. This was determined by making accurate scans of the laser beam in planes at different distances from the dewar. These scans were performed by translating a small hole coupler with a sensitive bolometer detector behind it across the beam. The beam scans also determined the amplitude variation over the cross-section of the beam. The laser operated in a good single mode, and thus emitted a gaussian beam, as verified by the beam scans. The HEB device was used in the direct detector mode for these experiments. Apart from this, the device and the lens/antenna were identical to what is used for the HEB mixer receiver. The operating temperature was 8.43 K and the device was brought to an electron temperature about equal to the critical temperature (9.5 K) by applying a DC bias current of 70 μ A. The laser power was attenuated until tests showed that the detector operated in its linear region. The responsivity (up to 2,400 V/W) and NEP (1×10^{-11} W/Hz^{1/2}) were sufficient for measuring the radiation pattern down to about 20 dB below the peak. Further details of this method will be published separately [12], [13].

The 3 dB beamwidth was determined to be 3.4 degrees at 1.56 THz and 2.15 degrees at 2.24 THz. Figure 3 shows the radiation pattern of the system at 1.56 THz in the H-plane. Note that there are no sidelobes down to the -20 dB level. The E-plane pattern is very similar. The beamwidth will be matched to the beam of the AST/RO telescope in the plane used for installing receivers. The TREND mixer block and IF amplifier will be housed in an existing dewar together with a 492 GHz SIS receiver system. Both will be able to observe simultaneously by using a polarization splitter.

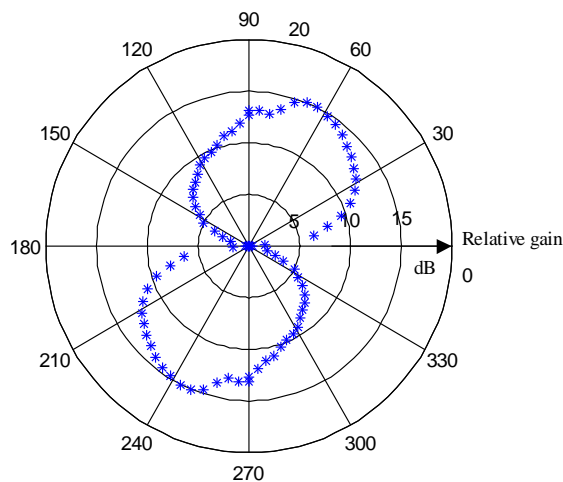

Figure 4. Polarization sensitivity of the log-periodic antenna measured at 1.56 THz.

We also measured the polarization sensitivity of the log-periodic antenna, which has not been documented in the THz region before. As is known from measurements at millimeter waves [14], the angle of polarization which yields the maximum response varies

periodically with the frequency. We confirmed this by measurements at two different wavelengths. The polarization response in Figure 4 was measured at 1.56 THz. The 2.24 THz polarization response "lobe" peaked at an angle which was about 45 degrees from the one at 1.56 THz, but was also wider. The log-periodic antenna measured at millimeter wavelengths in [14] also had five teeth on each side, and can be scaled in size to ours, while scaling the frequency by the same factor. One then finds that our measurements were performed at a (normalized) frequency higher than the highest frequency used at millimeter waves. We can therefore not do a direct comparison, but qualitatively the same features of polarization for maximum response which depends on frequency remain.

D. Local Oscillator

A common source of LO power for THz HEB mixers operated in the laboratory is a CO₂ laser pumped gas laser. By choosing various combinations of CO₂ pump laser frequencies and submillimeter laser gas, an enormous choice of discrete submillimeter laser frequencies is available. Each of these laser lines is typically tunable over a small frequency range of from 2-20 MHz. The spacing between the laser lines tends to be on the order of a few GHz, and it should thus in principle be possible to match a specific interstellar spectral line close enough to be within the band of a typical IF amplifier. One complication is that the reference literature lists the absolute frequency of most of these lines to an accuracy of only a few GHz. This is due to the optical technique usually used to measure the wavelength. A case in point is the NII line planned for the TREND receiver at 1461.3 GHz. The closest laser line appeared to be one due to CD₃OH, pumped by the 10P36 CO₂ line, with a listed wavelength of 205.8 μm. This wavelength converts to a frequency of 1456.7 GHz, and would result in an IF of 4.6 GHz. An accurate frequency measurement, described below, determined that this laser line occurs instead at 1459.3913 GHz, yielding a quite different IF of 1.7 GHz.

The much more accurate technique we used for measurement of the laser frequency was to heterodyne the laser frequency with a calibrated local oscillator (LO¹). The easiest way to obtain a calibrated THz LO source is to drive a submillimeter mixer with a low frequency source which generates harmonics internally which will mix with the laser producing a number of IF products. The frequency products found at the IF are described by

$$f_{\text{IF}} = m f_{\text{RF}} \pm n f_{\text{LO}} \quad (1)$$

where f_{RF} is the laser frequency, $n f_{\text{LO}}$ is the n th harmonic of the frequency synthesizer, and f_{IF} is the intermediate beat frequency.

The frequency of the CD₃OH line was measured at the UMass/Lowell Submillimeter-Wave Technology Laboratory (STL) using an existing receiver designed to operate over the range of 145 - 175 GHz. Despite being designed for a much lower

¹ The use of the term "LO" in this section refers to the multiplied signal used for frequency reference, whereas in the rest of the text, "LO" is used for the laser source itself.

frequency, this receiver proved able to conveniently measure laser frequencies in the THz range. The receiver uses an LO multiplied up from 10 GHz consisting of a quadrupler followed by an amplifier and a doubler producing a few mW at 80 GHz to drive the receiver's balanced mixer at the 2nd harmonic (160 GHz). Higher order harmonics of the LO (i.e. $240 \text{ GHz} \pm 22.5$, $320 \text{ GHz} \pm 30$, $400 \text{ GHz} \pm 37.5 \dots$) generated within the mixer should mix with higher frequency RF sources to produce beat frequencies which if within the IF detection bandwidth may be strong enough to measure. For example, the 18th harmonic of 81 GHz is 1458 GHz could be mixed with the 1456.7 GHz line to produce an IF within the operating range of this mixer.

A diagram of the measurement setup is shown in figure 5. The laser radiation was coupled into the mixer using a fast off-axis parabolic mirror to focus the energy down to a waist-size comparable to the input waveguide dimensions. The laser power at the mixer was measured at 1-2 mW. The mixer input was a simple smooth conical horn. The spectrum analyzer sweep width was set to 100 MHz during the search phase. The resolution BW of the spectrum analyzer was set to 10 KHz to offer the lowest practical noise floor and sweep speed.

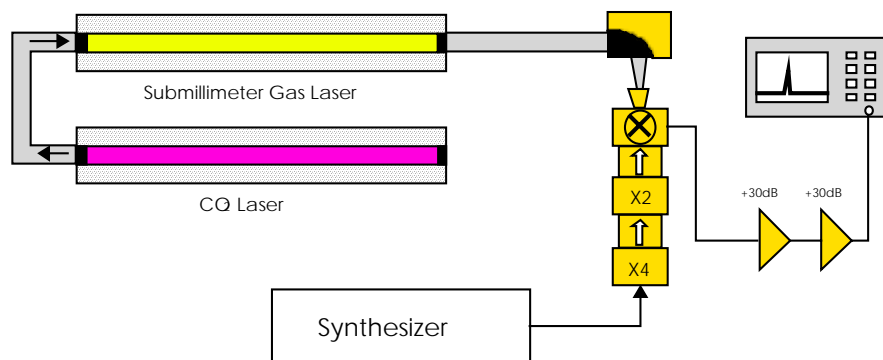

Figure 5. Diagram of the setup used for measurement of THz laser frequencies

To perform the measurement, the synthesizer was set to generate a harmonic output within 3 GHz of the estimated laser frequency. The synthesizer was adjusted until a beat with the laser was detected on the spectrum analyzer. The laser was then tuned over its gain bandwidth to determine the band edges and then tuned to the estimated center of the line. The synthesizer was adjusted to tune the beat to exactly 3 GHz. As a final check, the LO was shifted by 6 GHz to check for a 3 GHz beat with the other sideband. Although the measurement system was determined to be accurate to much better than one MHz, the uncertainty in the laser line center determines the ultimate measurement accuracy. Accurate frequencies of many other laser lines have been determined previously, but the techniques employed have been much more laborious than the one we used here. In order to explore the accuracy and limits of our technique, we measured previously measured lines in CH_3OH up to 3.1 THz and found excellent agreement with the published frequencies. The signal-to-noise ratio (S/N) in the measurement of the 1459.361 GHz line

(after optimization) was as high as 30 dB, as is evident from the spectrum analyzer recording in Figure 6. Even at 3.1 THz, a S/N \approx 10 dB was obtained.

As a practical note, it appears that the accurate frequency of any laser line to be used for THz heterodyne astronomy needs to be determined by an actual measurement, unless such data is available in the literature. On the other hand, once the frequency is known, the laser can be tuned to its maximum power, which establishes the absolute frequency to

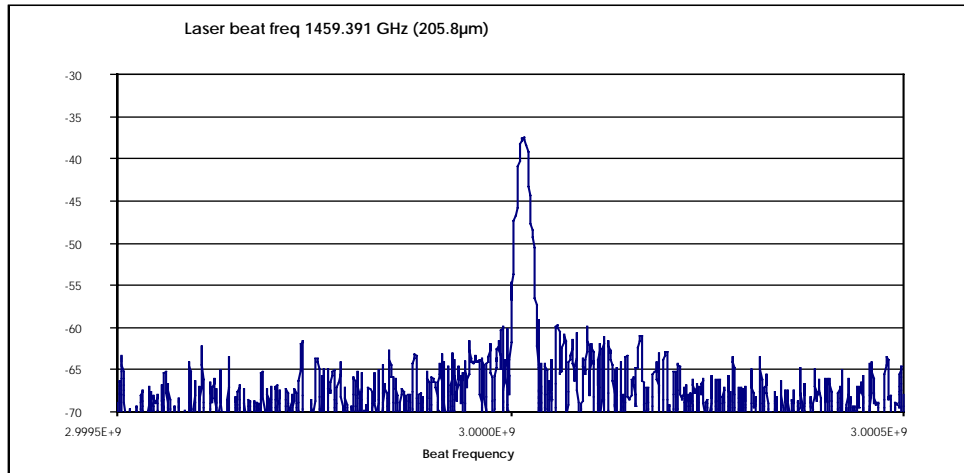

Figure 6. Beat frequency between the CD₃OH laser and the frequency measurement receiver, recorded on a spectrum analyzer.

within about 1 MHz, without the need for using a multiplier chain to control the frequency.

The CD₃OH laser line also demonstrates some of the other constraints on obtaining a laser local oscillator at any specific THz frequency. It was operated at STL with a maximum output power of about 2 mW. This required a quite large amount of CO₂ laser pump power (70 W), however, and lasing was only obtained when a very small (1 mm diameter) hole coupler was used, indicating low laser gain for this particular line. Because the center of the CO₂ pump laser line (10P36) is offset from the center of the CD₃OH line to be pumped by apparently more than 50 MHz, the laser cannot be operated at the optimum pump frequency, since this was outside the free spectral range of the pump laser. This appears to explain the lower than normal gain. We are working with DEOS, Inc. to design a laser which can yield sufficient THz power output while being pumped by a smaller CO₂ laser, appropriate for being installed at the South Pole site.

CD₃OH has a second line which we also operated at STL and measured to be at 1265.513 GHz. This line matches that of the J = 11→10 transition of CO, with a conveniently low IF of 1.5 GHz. There is no equally good match for the J = 13 → 12 CO transition. We have not yet settled on the optimum laser line for H₂D⁺.

E. Mixer block and biasing

We have designed a new mixer block which can directly replace another mixer block presently mounted in the designated dewar at the AST/RO facility. The mixer block will contain the lens, the substrate on which the NbN device and the antenna have been fabricated, and a circuit board which supplies the DC bias and connects the mixer to the IF amplifier. Figure 7 shows the present configuration of the circuit board, which is compatible with the wiring for the SIS mixer to be replaced. We are studying different versions of connecting a stabilizing resistor, as described in greater detail in another paper at this symposium [15]. We have shown, for example, that a series resistor in the bias lead of about 6 to 20 ohms (depending on the individual device) will stabilize the device even in its negative resistance region (without LO power).

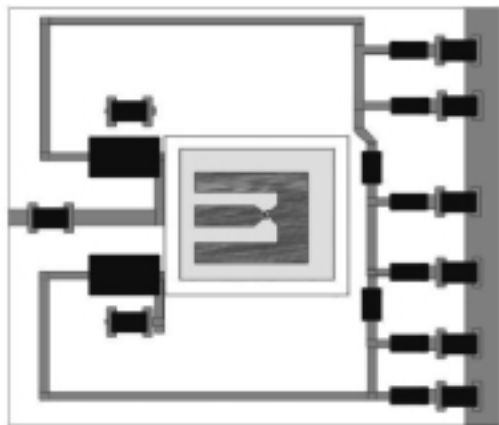

Figure 7. Bias/IF circuit for the TREND NbN receiver

IV. FUTURE EXTENSIONS

Given the availability of the laser LO at the AST/RO site, sufficient LO power is available such that future extensions to THz focal plane arrays are possible. Such arrays will also include MMIC IF amplifiers integrated with the HEB mixers/antennas, which will be developed under a new grant from the NASA Cross-Enterprise Technology Development program. We also plan to develop a capability for NbN film fabrication in collaboration with NIST/Boulder. This capability will benefit future implementation of NbN HEB mixer receivers for THz astronomy.

V. ACKNOWLEDGEMENTS

We gratefully acknowledge support for this project from the NSF program for Advanced Technologies and Instrumentation, Division of Astronomical Sciences, NSF award # AST 9987319. We also want to thank Dr. Eric Mueller of DEOS, Inc. for

generously giving us of his time for discussions and tests related to the TREND laser system.

VI. REFERENCES

- [1] A.A. Stark et al, "Plans for a 10-m Submillimeter Wave Telescope at the South Pole," SPIE Proceedings, Advanced Technology: Millimeter Wave, Radio and Terahertz Telescopes, Vol. 3357, pp. 495-506, 1998.
- [2] Stark, A. A., et al., "[The Antarctic Submillimeter Telescope and Remote Observatory \(AST/RO\)](#)", Publications of the Astronomical Society of the Pacific, May 2001, in press.
- [3] C. Walker et al., "Pole Star: An 810 GHz Array Receiver for AST/RO," this symp.
- [4] A.P. Lane, "[Submillimeter Transmission at South Pole](#)", in *Astrophysics From Antarctica*, A. S. P. Conf. Ser., eds. G. Novak and R. H. Landsberg, (San Francisco, CA: Astr. Soc. of the Pacific), 141, 289-295.
- [5] S. Paine et al., "A Fourier Transform Spectrometer for Measurement of Atmospheric Transmission at Submillimeter Wavelengths," Publications Of the Astronomical Society of the Pacific, **112**: 108-118, 2000.
- [6] J. Kawamura et al., "Successful Operation of a 1 THz NbN Hot-Electron Bolometer Receiver," Eleventh Intern. Symp. Space THz Technology, The University of Michigan, Ann Arbor, MI, May 2000, p. 57.
- [7] E. Gerecht et al, "Development of Focal Plane Arrays Utilizing NbN Hot Electron Bolometric Mixers for the THz Regime," Eleventh Intern. Symp. Space THz Technology, The University of Michigan, Ann Arbor, MI, May 2000, p. 57.
- [8] M. Kroug et al., "NbN Hot Electron Bolometric Mixers for Terahertz Receivers," Applied Superconductivity Conference, Newport Beach, VA, Sept. 2000.
- [9] E.R. Mueller, "Widely Tunable Laser-Sideband THz Source for Spectroscopy and LO Applications," this symposium.
- [10] S. Cherednichenko et al., "IF Bandwidth of Phonon Cooled HEB Mixers Made from NbN Films on MgO Substrates," Eleventh Intern. Symp. Space THz Technology, The University of Michigan, Ann Arbor, MI, May 2000, p. 228.
- [11] M. Ji et al., "Study of Parylene as Anti-Reflection Coating for Silicon Optics at THz Frequencies," Eleventh Intern. Symp. Space THz Technology, The University of Michigan, Ann Arbor, MI, May 2000, p. 407.
- [12] M. Ji, "Lens Coupled Printed Antenna Characterization," M.Sc. thesis, University of Massachusetts at Amherst, Department of Electrical and Computer Engineering, May 2001.
- [13] M.Ji et al., to be submitted for publication.
- [14] B.K. Kormanyos et al., "A Planar Wideband 80-200 GHz Subharmonic Receiver," IEEE Trans. Microwave Theory Techniques, MTT-41, p. 1730, 1993.
- [15] Y. Zhuang and K.S. Yngvesson, "Negative Resistance Effects in NbN HEB Devices," this symposium.