

Novel Multiplexing Technique for Detector and Mixer Arrays

Boris S. Karasik and William R. McGrath

*Center for Space Microelectronics Technology, Jet Propulsion Laboratory,
California Institute of Technology, Pasadena, CA 91109-8099.*

Future submillimeter and far-infrared space telescopes will require large-format (many 1000's of elements) imaging detector arrays to perform state-of-the-art astronomical observations. A crucial issue related to a focal plane array is a readout scheme which is compatible with large numbers of cryogenically-cooled (typically < 1 K) detectors elements. When the number of elements becomes of the order of thousands, the physical layout for individual readout amplifiers becomes nearly impossible to realize for practical systems. Another important concern is the large number of wires leading to a 0.1-0.3 K platform. In the case of superconducting transition edge sensors (TES), a scheme for time-division multiplexing of SQUID read-out amplifiers has been recently demonstrated [1]. In this scheme the number of SQUIDs is equal to the number (N) of the detectors, but only one SQUID is turned on at a time. The SQUIDs are connected in series in each column of the array, so the number of wires leading to the amplifiers can be reduced, but it is still of the order of N . Another approach [2] uses a frequency domain multiplexing scheme of the bolometer array. The bolometers are biased with ac currents whose frequencies are individual for each element and are much higher than the bolometer bandwidth. The output signals are connected in series in a summing loop which is coupled to a single SQUID amplifier. The total number of channels depends on the ratio between the SQUID bandwidth and the bolometer bandwidth and can be at least 100 according to the authors. An important concern about this technique is a contribution of the out-of-band Johnson noise which multiplies by factor \sqrt{N} for each frequency channel.

We propose a novel solution for large format arrays based on the Hadamard transform coding technique which requires only one amplifier to read out the entire array of potentially many 1000's of elements and uses ~ 10 wires between the cold stage and

room temperature electronics. This can significantly reduce the complexity of the readout circuits.

As an example of the technique, we consider an implementation using four detectors (TES detectors, for example) and a SQUID amplifier. The electrical diagram is shown in Fig. 1. All detectors are individually voltage biased. The output signal currents, I1 to I4, (from each detector resulting from the far-IR input signal) are summed in the input coil of a SQUID amplifier. In order to de-convolve the individual output signals from the total summed output, four sequential readings are performed. Each time a different polarity pattern is applied to the bias voltages of the detectors (shown in Fig.1). The mathematical basis for the de-convolution procedure uses the Hadamard Transform (HT) and the corresponding voltage polarity patterns are given by the Walsh-Hadamard functions [3,4]. (A very good description of the HT algorithm and its applications for imaging and spectroscopy can be found in [5]). The Walsh-Hadamard functions are binary functions (plus and minus ones) and for our purpose they correspond to positive and negative bias voltages across detectors. This assumes the detector current-voltage (IV) characteristic is symmetrical, which is the case for bolometers.

Let \mathbf{R} be the vector whose elements correspond to the summed outputs for each of the 4 polarity patterns. Then \mathbf{R} is the Hadamard transform of \mathbf{O} :

$$\mathbf{R} = \frac{1}{4} \mathbf{H}_4 \cdot \mathbf{O}, \quad (1)$$

where \mathbf{O} is the vector whose elements are the detector output currents I1 to I4. Inverting this equation gives \mathbf{O} , the actual signal output of the array. \mathbf{H}_4 is the corresponding Hadamard matrix. One of its possible construction is given by

$$\mathbf{H}_4 = \begin{bmatrix} 1 & 1 & 1 & 1 \\ 1 & -1 & 1 & -1 \\ 1 & 1 & -1 & -1 \\ 1 & -1 & -1 & 1 \end{bmatrix} \quad (2)$$

The Hadamard matrix is especially simple if its order (same as the number of detector elements) is 1, 2, 4, 8, 16, 32, ... 2^n where $n = \text{integer}$. The higher order matrices are all based on the basic 2×2 matrix:

$$\mathbf{H}_2 = \begin{bmatrix} 1 & 1 \\ 1 & -1 \end{bmatrix} \mathbf{H}_4 = \begin{bmatrix} \mathbf{H}_2 & \mathbf{H}_2 \\ \mathbf{H}_2 & -\mathbf{H}_2 \end{bmatrix} \mathbf{H}_{2N} = \begin{bmatrix} \mathbf{H}_N & \mathbf{H}_N \\ \mathbf{H}_N & -\mathbf{H}_N \end{bmatrix} \quad (3)$$

Examples of different order matrices can be found in [3,5]

Beside the major advantage of using just one amplifier, this technique provides an improvement in the signal-to-noise ratio (SNR) of the measurements. Indeed, during a single reading event, 4 signals are algebraically added whereas the electrical noise from individual detectors, i_noise_n , (which are independent) is totaled as $I_noise = \sqrt{\sum_n i_noise_n^2}$. The average SNR improvement for the aforementioned technique is $N^{1/2}$ [5].

The HT multiplexing technique can also be applied to the detectors with asymmetrical IV characteristics. In this case, instead of reversing the polarity one simply has to turn the bias on and off. The Hadamard matrix then consists of 0's and 1's and can be easily generated as: $\mathbf{S} = (\mathbf{H} + \mathbf{U})/2$, where \mathbf{U} is the unity matrix (we have adopted the "S-matrix" notation of reference 4, in this case). The SNR improvement is somewhat worse in this case: $(N+1)/2\sqrt{N} \approx \sqrt{N}/2$ (for large N) [5]. The multiplexing technique based on the "S-matrix" can be applied to arrays of mixers. However, the problem of feeding many high-frequency IF signals into one amplifier is definitely more severe than that for slow detectors.

The HT multiplexing technique has been used in optical imaging applications and spectroscopy for many years. However, the implementation of the optical masks was strictly mechanical. For example, a coded mask technique has been used in some X-ray telescopes to record an image using a single detector and a set of masks with transparent and opaque segments. The sequence of segments fulfills the aforementioned mathematical ordering sequence (e.g., that of Eq. 3). Since the encoding in this case occurs on the optical side of the detector system, the modification of the SNR is different from what we expect in our electrical scheme [5]. In optical multiplexers, the optical noises are not necessarily independent and after the de-convolution can be redistributed in such a way that the SNR in a pixel with a weak useful signal can become smaller. As a result, despite the potential average increase of the SNR, the contrast of the image can degrade. This *cannot* happen for the scheme which we propose. Our multiplexing of signals occurs on the "electrical" side of the detector system after all optical signals

(useful one and noise) are already detected. The SNR improvement takes place due to suppression of the electrical noise at the detectors output. The optical noise appears after the de-convolution as a part of the optical signal and its rejection is a matter of interpretation of the final data.

As can be expected for most signal processing techniques, the significant advantage of the HT multiplexing technique does not come for free. There are at least two issues which may hamper the use of this technique. Generation of the N electrical bias patterns would certainly take time especially when N is of the order of thousands. Figure 2 illustrates the time diagram which should be expected in bolometers. The required time to hold a certain voltage across a detector must be at least τ (the bolometer time constant). This allows for accumulation of the energy of the signal in the bolometer. So the total time required to obtain one image would be $N\tau$ which may be unacceptably long if τ is large. This becomes less of an issue however if the bolometers are fast. For example, if we consider a hot-electron direct detector (HEDD) which is a recently proposed micron-size version of a TES bolometer [6], the intrinsic time constant given by the electron-phonon relaxation time can be ≈ 1 ms [7]. However, modification of the time constant due to the electro-thermal feedback mechanism would reduce it to 30-100 μ s. In this case even a 10^4 -element array can be read out in ~ 1 sec.

The second issue is the generation of the electrical polarity patterns. If the patterns are generated outside of the dewar then this technique does not have any advantage in reducing the heat load on the cryogenic system. One would need to run $2N$ wires to bias the bolometers. However, due to the binary nature of the Walsh-Hadamard functions and the cyclic properties of S-matrices from which the Hadamard matrices can be originated [5], a better solution is available. We envision a custom-designed digitally-controlled pattern generator circuit located on one of cold stages near the array (see Fig. 3). Such a circuit would generate a new polarity pattern at N serial outputs every time a new control bit arrives at the input. It would need just a few wires for bias and control input. The read-out SQUID would typically need 6 wires. The design of the pattern-generator would depend on the cooling requirements. If the detectors need to be moderately cooled (≥ 1 K), the circuit can be placed on a 4K-stage. In this case, it could use semiconductor transistor technology. For deeper cooling ($\ll 1$ K), very low-power Josephson logic circuits could be used.

The HT multiplexing technique should work well with arrays of HEDD bolometers. In addition to the record sensitivity predicted at submillimeter wavelengths [6], the

HEDD bolometers can be fabricated on bulk dielectric substrates (Si, sapphire) (see Fig.4). It is certainly attractive to combine such an array with an on-chip Walsh-Hadamard function generator. Another advantage, as was mentioned above, is the small time constant which makes the time needed to take one image short enough for most applications.

In conclusion, a new approach based on Hadamard Transform coding is proposed for multiplexing of large array of detectors. The method uses only one amplifier to read out many detectors and does not put any hard limit on the number of detectors (10^4 detectors may be possible). The signal-to-noise ratio for a single reading can be improved by factor of square root of the number of detectors. For subkelvin cryogenic applications this approach can be an important solution drastically reducing the number of wires between the cold stage and the room temperature electronics.

We thank L.A. Luizova, A.D. Khakhaev for sharing their experience with Hadamard Transform based algorithms for image recognition. Fruitful discussions with P.H. Siegel, A. Neto, M. Seiffert, and V. Kapluneko are greatly appreciated.

This research was performed by the Jet Propulsion Laboratory (California Institute of Technology) under a contract with the National Aeronautic and Space Administration and was partly supported by the Caltech President's Fund.

References

1. J.A. Chervenak, K.D. Irwin, E.N. Grossman, J.M. Martines, C.D. Reintsema, and M.E. Huber, *Appl. Phys. Lett.* **74**, 4043 (1999); *Nucl.Instrum.and Methods in Physics Research A***44**, 107 (2000).
2. J. Yoon, J. Clarke, J.M. Gildemeister, A.T. Lee, M.J. Myers, P.L. Richards, and J.T. Skidmore, *Appl. Phys. Lett.* **78**, 371 (2001).
3. N. Ahmed and K.R. Rao, *Ortogonal Transforms for Digital Signal Processing*, Springer-Verlag, Berlin-Heidelberg-New York, 1975, pp.89-94.
4. L.A. Luizova and A.D. Khakhaev, *private communication*.
5. M.Harwitt and N.J.A.Sloane, *Hadamard Transform Optics*, Academic Press, New York, San Francisco, London 1979.

6. B.S. Karasik, W.R. McGrath, H.G. LeDuc, and M.E. Gershenson, *Superconductor: Science & Technology* **12**, 745 (1999); B.S. Karasik, W.R. McGrath, M.E. Gershenson, and A.V. Sergeev, *J. Appl. Phys.* **87**, 7586 (2000).
7. M.E. Gershenson, D. Gong, T. Sato, B.S. Karasik, W.R. McGrath, and A.V. Sergeev, *Proc. 11th Int. Symp. on Space Terahertz Technology*, May 1-3, 2000, University of Michigan, Ann Arbor, MI, pp.514-523.
8. B.S. Karasik, M.C. Gaidis, W.R. McGrath, B. Bumble, and H.G. LeDuc, *Appl. Phys. Lett.*, **71**, 1567 (1997).

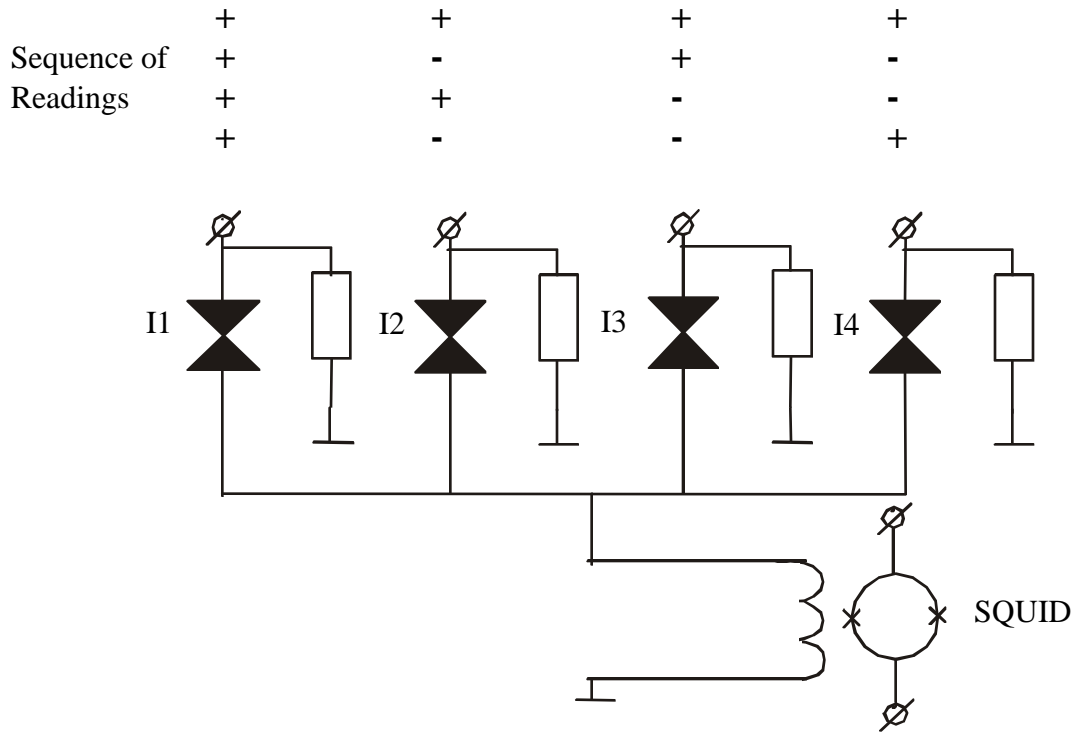

Fig. 1. An electrical circuit for multiplexing of 4 transition-edge sensors. All four detectors are individually voltage biased. Signal currents (I1-I4) from all detectors are summed into a SQUID input coil. The multiplexing is done by applying a sequence of four polarity patterns of bias voltage. The deconvolution of the signal distribution among the detectors is done using the Hadamard Transform algorithm.

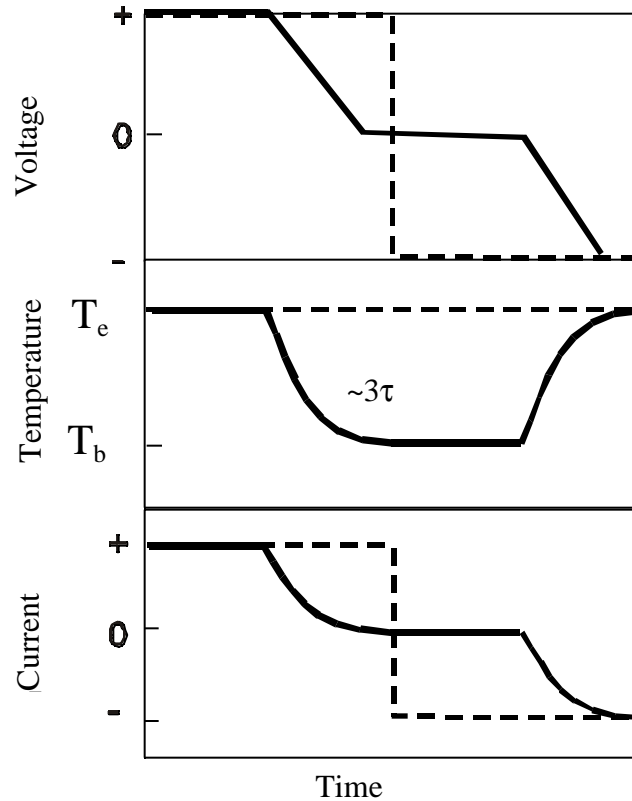

Fig. 2. The time diagram for switching polarity across a bolometer. If the switching is done fast (dashed line) comparing to the bolometer response time τ , the electron temperature does not “sense” that and remains constant. So, the current just changes its polarity and the device is ready again. The polarity pattern should be held during a period of at least τ to let the bolometer collect all the signal energy. If the switching is slow (solid line) then a time of at least 2-times- 3τ would add to the signal hold time, which corresponds to the time required for the bolometer to warm-up and cool-down.

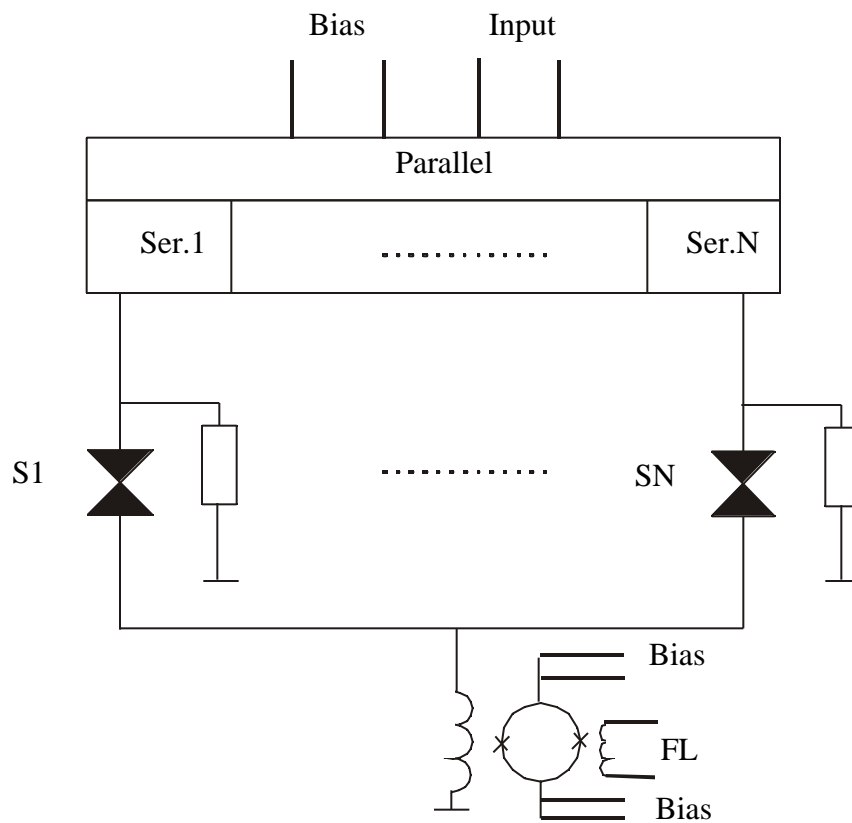

Fig. 3. Schematic block-diagram for generating Walsh-Hadamard electrical bias patterns A new bias pattern is generated each time a bit is received at the input. This circuit may need just a few wires for bias and signal input. A SQUID amplifier would need 6 wires: 4 for bias and 2 for the feedback loop (FL).

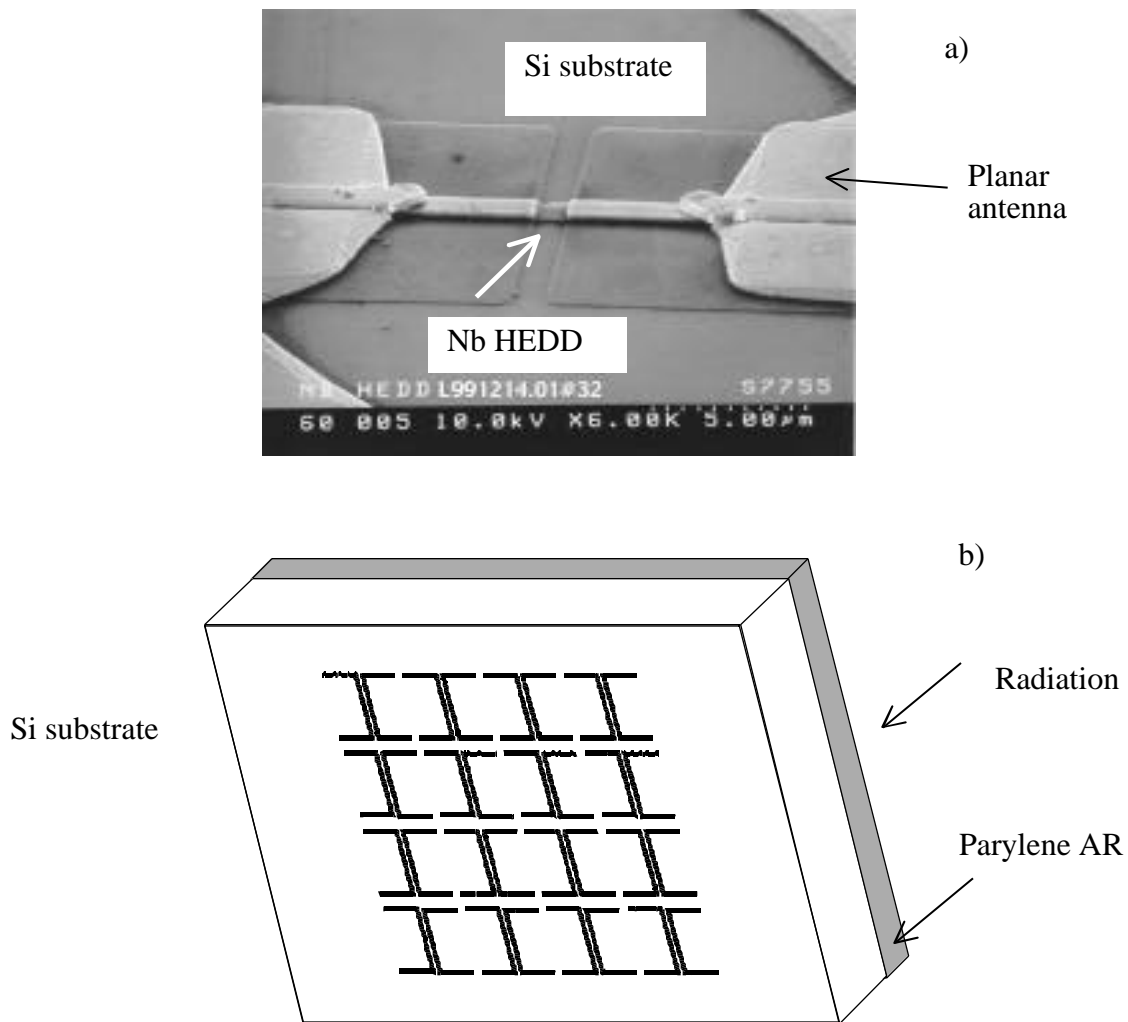

Fig. 4. A monolithic array of antenna-coupled HEDD bolometers for submillimeter wavelengths.

a). an SEM image of a $1 \times 1 \mu\text{m}^2$ Nb prototype HEDD bolometer on a Si substrate. The device is combined with a spiral antenna (not shown). The detector was fabricated by H.G. Leduc at JPL.

b). A 4×4 array of bolometers for submillimeter wavelengths. Narrow band antennas will be useful for lower T_c bolometers to limit background loading effects. A twin-slot antenna (shown in the figure) is a possible choice since it has a relatively narrow one octave bandwidth. Such antennas have been used up to 2.5 THz [8] for hot-electron superconducting mixers. A parylene anti-reflecting (AR) coatings works well for Si at THz frequencies.