

# A 200 GHz cloud radar multiplexing antenna

Stuart Froud, Manju Henry, Peter G. Huggard, Duncan A. Robertson, Soe Min Tun, Hui Wang & Richard Wylde

A team consisting of the STFC Rutherford Appleton Laboratory (RAL), Thomas Keating and St Andrews and Leicester universities are building and demonstrating a 200 GHz, 1.5 mm wavelength, cloud profiling radar, establishing the basis for the future operation of a similar Earth observing radar in space. The pulsed Doppler radar is called GRaCE: G-band Radar for Cloud Evaluation, and is grant funded by the UK Space Agency through the UK Centre for Earth Observation Instrumentation [1].

The small wavelength of a 200 GHz space radar will provide enhanced global information on the distribution of small droplets in the atmosphere. When operated in tandem with existing lower frequency space radars, the dual wavelength observations will enable atmospheric scientists to better characterize the microphysical properties of hydrometeors in water and ice clouds. Such information is needed to improve the accuracy of societally important numerical weather prediction models

A model of the GRaCE hardware is set out below in Figure 1.

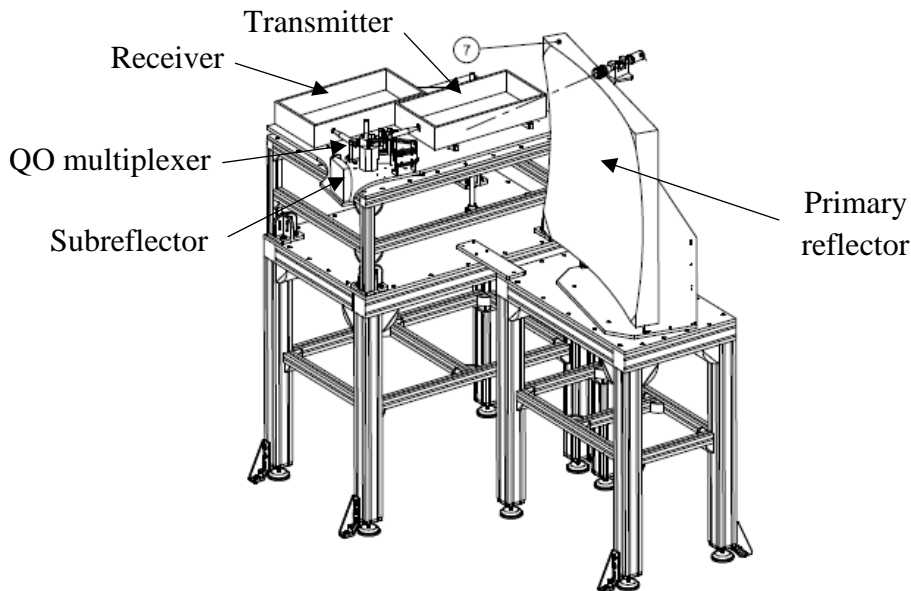

Figure1: The GRaCE hardware indicating the major elements.

The radar is designed to have the following parameters:

Parameter	Ground Radar	Space Radar	Comment: Ground/Space
Transmit frequency	200 GHz	160 – 260 GHz	G: Fixed, but can be set at design stage S: Fixed by EIK within $\pm 1$ GHz
Transmit power	> 100 mW	100 W	G: Single high power Schottky multiplier
Transmitter Technology	Schottky	EIK	<b>G, S:</b> High power Schottky frequency multiplier <b>S:</b> Extra EIK linear amplifier required
Transmit polarisation	Circular	Circular	From high performance quasi-optical Tx/Rx diplexing
Receive polarisation			
Main antenna diameter	1 m	$\geq 2$ m	<b>G:</b> Set by project budget <b>S:</b> Set by satellite payload and budget
Beam divergence	$\approx 0.1^\circ$	$\approx 0.05^\circ$	<b>G, S:</b> Set by main antenna diameter
Antenna Gain	64 dBi	70 dBi	<b>G, S:</b> Set by main antenna diameter
Antenna sidelobe level	<40 dB	<50 dB	<b>S:</b> Very low sidelobes required to suppress ground reflections off-axis
Range resolution	50 to 500 m	500 m	<b>G:</b> Selectable in software, trade off with sensitivity <b>S:</b> Similar to CloudSat & EarthCARE
Pulse length / coding	20 ns to 1 $\mu$ s	3.3 $\mu$ s	Determines range resolution
Maximum instrument range	12 km	500 km	<b>G:</b> Few clouds above 11 km at UK latitudes <b>S:</b> Satellite altitude $\sim$ 400 km, atmosphere top @ 380 km
Receiver Noise Figure	6 dB	6 dB	Set by receive mixer and optics / radome losses
Receiver Technology	Schottky	Schottky	<b>G, S:</b> Sub-harmonically pumped Schottky diode mixer, potentially with LNA
Sensitivity	-26 dBZ	-20 dBZ	<b>G:</b> At 1 km range, single 400 ns pulse <b>S:</b> At 400 km range, single shot

This paper covers the development of the 200 GHz multiplexing antenna for GRaCE.

Unusually, the multiplexer does not rely upon gyrotropic materials (ferrites) as would typically be used for linear polarisation. Instead it follows an approach used in the JAXA 94 GHz radar in the ESA/JAXA EarthCARE mission [2], involving transmission and reflection of circularly polarised beams. In that case, one of two corrugated horns attached to the sources transmits a beam to a mechanically switchable mirror (coloured brown in left hand part of Figure 2) and is reflected to a refocusing mirror (coloured purple) following which it passes through an analysing polarizing grid (coloured gold).

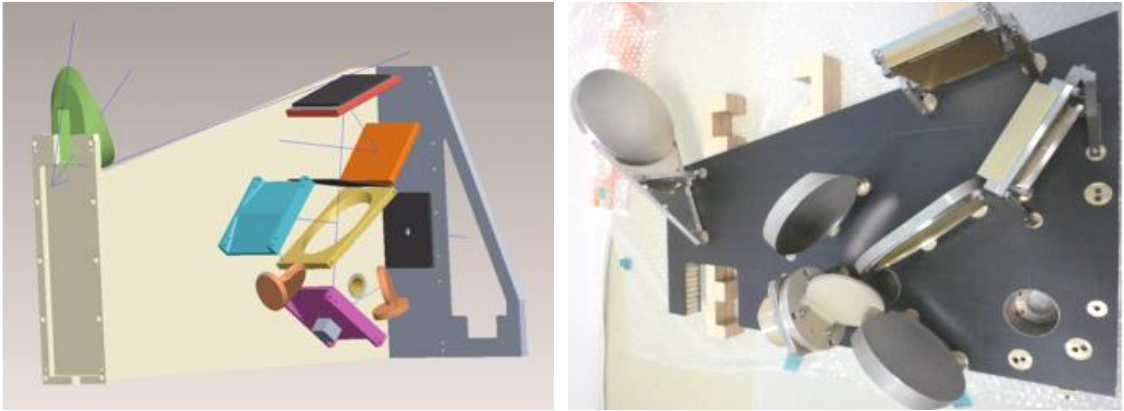
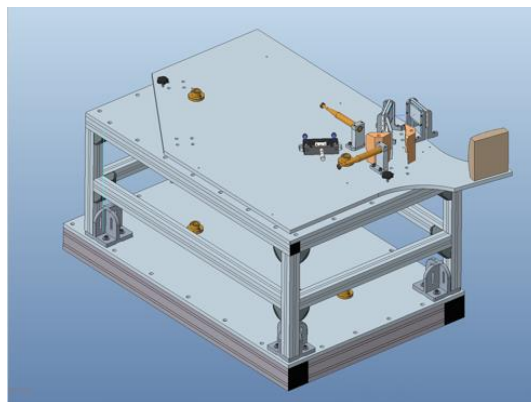

**Figure 2: Design and realisation of the 94 GHz quasi-optical multiplexer produced by TK for the Cloud Profiling Radar on EarthCARE**

The beam then passes to an Inatani-type Martin-Puplett Diplexer [3] which acts as the circular polarizer (coloured blue-green). The radiation then passes to the sub reflector (coloured green) and up to the main reflector, not shown, for transmission.

The returning beam, reflected by hydrometeors, follows a reversed path, being diverted sideways at the analysing grid (coloured gold), and a refocusing mirror (coloured blue). A second switchable mirror directs the beam to one of two corrugated horns feeding the low noise amplifier receivers. The switching mirrors provide transmit and receive redundancy in the space mission: they are not required for GRaCE.

The scheme used for EarthCARE has been adapted to operate at 200 GHz for GRaCE. Mechanical design was performed in PTC CREO – Figure 3.



**Figure 3: Design of the GRaCE optics bench, with the 200 GHz quasi-optical multiplexer and sub-reflector.**

Figure 4 shows images of the constructed quasi-optical multiplexer, with a pair of ultra-Gaussian feedhorns, and the system under test at RAL.



**Figure 4: GRaCE 200 GHz quasi-optical multiplexer close up (left) and under VNA test at RAL with Dr Richard Wyld of TK Ltd. (right).**

Insertion loss and isolation measurements were performed using a vector network analyser and frequency extender modules, Figure 4 right. At 200 GHz, the single pass insertion loss of the network is at the 0.6 dB level, and transmit/receive isolation at a very useful 60 dB.

Testing of the whole instrument at STFC's Chilbolton Observatory is to start shortly.

[1] [ceoi.ac.uk](http://ceoi.ac.uk)

[2] [www.esa.int/Applications/Observing\\_the\\_Earth/The\\_Living\\_Planet\\_Programme/Earth\\_Explorers/EarthCARE/Satellite](http://www.esa.int/Applications/Observing_the_Earth/The_Living_Planet_Programme/Earth_Explorers/EarthCARE/Satellite)

[3] [smiles.tksc.jaxa.jp/old/document/article1999/inatani\\_thz1999\\_fsp.pdf](http://smiles.tksc.jaxa.jp/old/document/article1999/inatani_thz1999_fsp.pdf)